

Proceedings of the Problem@Web International Conference

Vilamoura, Portugal 2-4 May, 2014



Technology, creativity and affect in
mathematical problem solving

EDITORS

Susana Carreira | Nélia Amado | Keith Jones | Hélia Jacinto

Universidade do Algarve



Technology, creativity and affect in
mathematical problem solving
Vilamoura, Portugal 2-4 May, 2014

Proceedings of the Problem@Web International Conference: Technology, creativity and affect in mathematical problem solving

Editors

Susana Carreira, Nélia Amado, Keith Jones, and Hélia Jacinto

Copyrights © 2014 left to the authors

All rights reserved

May, 2014

Faro, Universidade do Algarve

ISBN 978-989-8472-50-2

Cover Photo: Vilamoura Marina (Courtesy of the Municipality of Loulé)

Cite as:

Carreira, S., Amado, N., Jones, K., & Jacinto, H. (Eds.) (2014). *Proceedings of the Problem@Web International Conference: Technology, creativity and affect in mathematical problem solving*. Faro, Portugal: Universidade do Algarve.

Proceedings available for download at: <http://hdl.handle.net/10400.1/3750>.



TABLE OF CONTENTS

Acknowledgements	vii
Organizing Committee	viii
International Scientific Committee	viii
The Problem@Web Project: An overview	ix
Opening Note from the Editors	1
<i>Susana Carreira, Nélia Amado, Keith Jones, Hélia Jacinto</i>	

PLENARY SESSIONS

LECTURES

Math problem, Internet and digital mathematical performance	4
<i>Marcelo Borba</i>	
Roles of aesthetics and affect in mathematical problem solving	6
<i>Norma Presmeg</i>	
The curriculum, creativity and mathematical competitions	8
<i>Jaime Carvalho e Silva</i>	
Multiple solution problems in computerized and non-computerized environments: what difference does it make?	10
<i>Michal Tabach</i>	

PANEL

Present and future roles of online math competitions in the education of twenty-first century young students	12
<i>João Pedro da Ponte, Keith Jones</i>	

KEYNOTE ADDRESSES

Strand 1 – Technology: strategies and representations used in technology-based problem solving approaches

- The use of digital tools in web-based mathematical competitions: degrees of sophistication in problem solving-and-expressing** 14
Hélia Jacinto, Sandra Nobre, Susana Carreira, Nélia Amado

Strand 2 – Creativity: students' mathematical creativity in mathematical problem solving

- Highlighting creativity in children's beyond-school mathematical problem solving** 16
Nuno Amaral, Susana Carreira

Strand 3 – Affect: attitudes and emotions of students, parents and teachers regarding mathematical problem solving

- The affective relationship of youngsters and parents with mathematics and problem solving in inclusive mathematical competitions** 19
Nélia Amado, Susana Carreira, Eugénia Castela, Rosa Antónia Tomás Ferreira

PARALLEL SESSIONS

RESEARCH PAPERS

Strand 1 – Technology: strategies and representations used in technology-based problem solving approaches

- Digital storytelling for improving mathematical literacy** 23
Giovannina Albano, Anna Pierri
- Using statistical software in basic education: difficulties and affordances** 35
Cláudia Fernandes, João Pedro da Ponte
- Correlation between different learning styles and the use of wiki in learning** 47
Nashwa Ismail, Julie-Ann Edwards, Gary Kinchin
- The role of peer and computer feedback in student's problem solving** 59
Júlio Paiva, Nélia Amado, Susana Carreira
- Simulating random experiments with computers in high school level teaching** 71
Bernard Parzys
- Electronic forums: an added value when solving initial algebraic problems** 84
M. Pilar Royo, Joaquin Giménez

Preservice high school teachers' construction and exploration of dynamic models of variation phenomena	96
<i>Manuel Santos-Trigo, Matías Camacho-Machín, Carmen Olvera-Martínez</i>	

The role of using technology and creativity in developing positive dispositions toward mathematical problem solving	108
<i>Mehmet Türegün, Luis Conde</i>	

Strand 2 – Creativity: students' mathematical creativity in mathematical problem solving

How to foster creativity in problem posing and problem solving activities	120
<i>Cinzia Bonotto, Lisa Dal Santo</i>	

Mathematical problems in basic education	133
<i>Virginia Furlanetto, Maria Madalena Dullius, Italo Gabriel Neide</i>	

Dimensions of mathematically creative processes in early childhood	144
<i>Melanie Münz</i>	

Creative advantages of visual solutions to some non-routine mathematical problems	156
<i>Norma Presmeg</i>	

The borrowers: using transportation, addresses, and paralelepípedos to prompt creativity using Ethnomodeling	168
<i>Daniel Clark Orey, Milton Rosa</i>	

Creativity in mathematics class: how can it emerge?	179
<i>Sandra Pinheiro, Isabel Vale</i>	

Strategies used by elementary grade students in Mathematics Olympiad tests	192
<i>Márcia Jussara Hepp Rehfeldt, Marli Teresinha Quartieri, Maria Madalena Dullius</i>	

Writing problem stories: developing creativity through the integration of mathematics and language	204
<i>Fátima Sardinha, Pedro Palhares, Fernando Azevedo</i>	

Revealing the inner connections of math using a clock puzzle	217
<i>Sabine Stöcker-Segre</i>	

Mathematical creativity through the eyes of future teachers	229
<i>Isabel Vale, Ana Barbosa, Lina Fonseca</i>	

Noticing creativity issues when future teachers analyzing problem solving dialogues	242
<i>Yuly Marsela Vanegas, Joaquín Giménez</i>	

Strand 3 – Affect: attitudes and emotions of students, parents and teachers regarding mathematical problem solving

Practice in the mathematical modelling environment	254
<i>Bárbara Cândido Braz, Lilian Akemi Kato</i>	
Cognitive scaffolding for problem solving: use of the practical worksheet	265
<i>Jaguthsing Dindyal, Eng Guan Tay, Khiok Seng Quek, Yew Hoong Leong, Tin Lam Toh, Pee Choon Toh, Foo Him Ho</i>	
Affective issues in solving challenging mathematical problems within an inclusive competition	275
<i>Rosa A. Tomás Ferreira, Susana Carreira, Nélia Amado</i>	
Identifying cognitive-affective interaction phenomena in a technological mathematical context	288
<i>Inés M. Gómez-Chacón</i>	
An exploratory study on using the think-pair-share cooperative learning strategy for students to solve mathematics problems in a Hong Kong primary school	300
<i>Andrew P. Kwok, Alexandria Lau</i>	
A mathematical congress: a window to affect in problem solving	308
<i>Teresa Pimentel, Isabel Vale</i>	
Teachers' involvement and learning in a lesson study	321
<i>João Pedro da Ponte, Marisa Quaresma, Mónica Baptista, Joana Mata-Pereira</i>	

E-POSTERS

Teaching and learning mathematics for creativity through challenging tasks	335
<i>Ana Barbosa, Isabel Vale, Teresa Pimentel</i>	
Developing positive dispositions toward mathematical problem solving	337
<i>Luis Conde, Mehmet Türegün</i>	
Posing and solving problems in mathematical modeling scenarios	338
<i>Cristina Esteley, María Mina, Mónica Villarreal</i>	
DROIDE II – Robots in mathematics and informatics education – final results of the project	339
<i>Elsa Fernandes</i>	
Problem solving: carving out spaces for creativity, communication, and perseverance	340
<i>Deborah Moore-Russo, Anne Izydorczak, Harry T. O'Malley</i>	
Proof and creativity in a geometrical problem from a regional Mathematical Olympiad	341
<i>Juan Rodriguez, Nélia Amado, Susana Carreira, Sílvia Reis</i>	

Information environment for mathematics education based on relationship development theory	342
<i>Karasawa Toshimitsu</i>	
Problem solving in modeling scenarios with experimental activities: the role of information and communication technologies	344
<i>Mónica Villarreal, María Mina, Cristina Esteley</i>	
Reviewers	345
List of participants	346
Sponsors	350

ACKNOWLEDGEMENTS

This Conference was kindly supported by several sponsors and organizations. We wish to express our special thanks to:

- Câmara Municipal de Loulé
- Hotel Dom Pedro Golf
- Springer
- Dismel
- Texas Instruments
- Pelcor
- Raiz Editora
- Associação de Professores de Matemática (APM)
- Fundação para a Ciência e a Tecnologia (FCT)
- Região de Turismo do Algarve

ORGANIZING COMMITTEE

Nélia Amado [Chair], *Faculty of Sciences and Technology, University of Algarve, Portugal*
Hélia Jacinto, *Research Unit of the Institute of Education of the University of Lisbon, Portugal*
Isa Martins, *Pinheiro e Rosa Schools Grouping, Faro, Portugal*
Jaime Carvalho e Silva, *Faculty of Sciences and Technology, University of Coimbra, Portugal*
Juan Rodriguez, *Faculty of Sciences and Technology, University of Algarve, Portugal*
Nuno Amaral, *Basic School 2,3 Sophia de Mello Breyner Andresen, Lisbon, Portugal*
Rosa Antónia Tomás Ferreira, *Faculty of Sciences, University of Porto, Portugal*
Sandra Nobre, *Research Unit of the Institute of Education of the University of Lisbon, Portugal*
Sílvia Reis, *Schools Grouping of Valpaços, Portugal*
Susana Carreira, *Faculty of Sciences and Technology, University of Algarve, Portugal*

INTERNATIONAL SCIENTIFIC COMMITTEE

Keith Jones [Co-chair], *University of Southampton, United Kingdom*
Susana Carreira [Co-chair], *Faculty of Sciences and Technology, University of Algarve, Portugal*
Guida de Abreu, *Oxford Brookes University, United Kingdom*
Inés Gómez-Chacón, *Faculty of Mathematics, Complutense University of Madrid, Spain*
Isabel Vale, *School of Education, Polytechnic Institute of Viana do Castelo, Portugal*
Jaime Carvalho e Silva, *Faculty of Sciences and Technology, University of Coimbra, Portugal*
Joaquin Giménez, *University of Barcelona, Spain*
João Filipe Matos, *Institute of Education, University of Lisbon, Portugal*
João Pedro da Ponte, *Institute of Education, University of Lisbon, Portugal*
Marcelo Borba, *State University of São Paulo, Brazil*
Matías Camacho-Machín, *University of la Laguna, Spain*
Michal Tabach, *Tel Aviv University, Israel*
Nélia Amado, *Faculty of Sciences and Technology, University of Algarve, Portugal*
Norma Presmeg, *Illinois State University (Professor Emerita), United States of America*
Rosa Antónia Tomás Ferreira, *Faculty of Sciences, University of Porto, Portugal*

THE PROBLEM@WEB PROJECT: AN OVERVIEW

The Problem@Web International Conference is a satellite conference of a research project running in Portugal between December 2010 and June 2014, jointly developed by the Institute of Education of the University of Lisbon and by the University of Algarve. As the completion of the Problem@Web Projectⁱ approaches, the research team and the project external consultant (Prof. Keith Jones) took upon themselves the task of promoting a conference aiming to present and disseminate the main results of the research undertaken within the project and to create the opportunity of sharing and discussing neighbouring perspectives and ideas from scholars and researchers in the international field.

The project was launched to embrace the opportunity of studying mathematical problem solving beyond the mathematics classroom, by looking at the context of two web-based inclusive mathematical competitions, running in the south of Portugal – Sub12[®] and Sub14[®]. By addressing such a rich multi-faceted environment, the project intended to explore, in an integrated manner, issues that combine cognitive, affective and social aspects of the problem solving activity of young students. Therefore, the field of research was clearly based on inclusive mathematical competitions that occur mainly through the Internet, involving a clear digital communicational activity and inducing strong resonance with the homes and lives of students.

The two competitions, Sub12 and Sub14, have been running since 2005, promoted by the Mathematics Department of the Faculty of Sciences and Technology of the University of Algarve. The Sub12 addresses students in 5th and 6th grades (10-12 year-olds) and the Sub14 addresses students in 7th and 8th grades (12-14 year-olds). The two competitions are web-based, located in the same website (<http://fctec.ualg.pt/matematica/5estrelas/>), have similar rules and operate in parallel. They involve two distinct phases: the Qualifying and the Final.

The Qualifying phase develops entirely at distance through the website and consists of a set of ten problems each posted every two weeks. During the Qualifying phase competitors may participate individually or in small teams of two or three elements. They have to send their answers to the given problems by e-mail or through the digital form available at the website that allows attaching files. The answers to the problems are received in e-mail accounts specifically devoted to that purpose and the organization replies to every participant, with formative feedback, suggestions, clues or appraisal. Participants are allowed to resubmit revised solutions as many times as needed within the respective deadline.

The Final is a half-day on-site contest held at the university campus with the presence of the finalists, their families and teachers. At the Final, participants are given a set of five problems to be solved in limited time with paper and pencil. Everyone is competing individually and there is no technology available. The written answers to the problems are corrected anonymously by a jury. In the meantime parents, teachers

and other accompanying guests have a program devoted to them (usually a seminar or a workshop about mathematical ideas, especially prepared for that occasion). The Final culminates with the awarding ceremony of the three winners who receive prizes and honour diplomas.

Throughout the history of this competition a number of distinctive characteristics have been standing out: i) it proposes non-routine word problems, usually allowing several ways to be solved; ii) problems are not intended to fit any particular school curricular topic; iii) the main trend is on moderate mathematical challenges; iv) the competition explicitly requires participants to expose the process to find the solution; v) it is close to teachers and families in the sense that it encourages their support to the young participants; vi) opportunities for reformulating and resubmitting answers are offered to all participants; vii) all types of media to find and develop solutions are welcome; viii) communication and interaction is carried out through digital web-based and email infrastructures; ix) interesting and diverse proposed solutions are published on the competition website; x) the competitive component is concentrated on the Final phase of the competition.

Based upon this context, the Problem@Web project has defined three research foci:

- (a) Ways of thinking and strategies in mathematical problem solving, forms of representation and expression of mathematical thinking, and technology-supported problem solving approaches;
- (b) Beliefs, attitudes and emotions related to mathematics and mathematical problem solving, both in school and beyond school, considering students, parents and teachers.
- (c) Creativity manifested in the expression of mathematical solutions to problems and its relation to the use of digital technologies.

The empirical research involved two main approaches – extensive and intensive – and the data analysis combined quantitative and qualitative methods. The extensive approach drew on the following data: a database of participants' digital productions in three editions of the competitions (emails and attached files); the finalists' written solutions collected in the Finals; the answers to a mini-questionnaire about each proposed problem during the Qualifying phase (online); and an online survey to all students from the Algarve (online). The intensive approach aimed to in-depth study and the collected data included: interviews with participants (including former participants some years after leaving the competitions), interviews with parents (or family members) of participants; interviews with teachers who have students participating; participant observation and video-recording of the Finals; participant observation in regular classes where problems from the competitions were proposed; ethnographic observation of participants in their home environment.

The project has implemented qualitative and quantitative data analysis methods, namely content analysis, case study research, statistical descriptive analysis, and multivariate statistical analysis.

For the theoretical framework particularly relevant theories were those that suggest and endorse the expression of mathematical thinking as an integral component of the problem solving process. Therefore, our research has elected solving-and-expressing as a central unit of the problem solving activity. Moreover, as our aim is to study students' problem solving with the digital technologies of their choice, either at school or at home, the project pays particular attention to the expression of students' mathematical ideas mediated by digital tools. In particular, the interweaving of technological fluency with mathematical knowledge (and problem solving ability) has motivated the study of participants' "techno-mathematical fluency".

In connection to the challenging and inclusive character of the competition, the project has considered some affective aspects surrounding it. The concept of inclusive competition, rather than the competitive element, and the idea of challenging mathematical problem of moderate degree are key notions that structure the theoretical view on the research strand devoted to affect. Parental involvement, help-seeking in problem solving, perceived difficulty in tackling the problems from the competition, along with attitudes, beliefs and emotions of participants, their parents and teachers, concerning school and beyond-school mathematics, the participation in the competitions, and problem solving in general are strategic ideas in the research developed.

Finally, some characteristics of the way in which the competitions work, among which stands out an extended time for the submission of answers to the problems, the possibility of using all available resources and the voluntary nature of participation, are factors that promote the emergence of mathematical creativity. Our option in researching students' mathematical creativity in problem solving is to divide attention between the mathematical representations and the strategies devised by the participants. Considering the final quality of a product as one of the ways in which creativity can be approached both in mathematics as in other areas, we have examined students' creative solutions to problems by proposing analytical forms of consensual assessment of creativity and by putting emphasis on an inclusive view of creativity that accounts for novelty and usefulness in mathematical problem solving.

The Problem@Web Project has so far attained a significant number of interventions in research conferences as well as several national and international publications. It is our intention to develop the work produced so far and to strengthen it through the contribution of a wider community, namely in the form of an international conference devoted to the three strands that are the pillars of the very existence of the project.

Susana Carreira (Principal Investigator)

NOTES

ⁱ Acronym for the project Mathematical Problem Solving: Views on an interactive web based competition (Sub12 & Sub14), funded by Fundação para a Ciência e Tecnologia under the grant PTDC/CPE-CED/101635/2008.

OPENING NOTE FROM THE EDITORS

The Problem@Web International Conference is an opportunity to gather together participants from the research community in mathematics education as well as from related research areas such as the psychology of education, technology education, mathematics popularization and other relevant fields that converge to the study of mathematical problem solving in different educational environments in the twenty-first century. The conference has elected three major topics presented as strands, technology, creativity, and affect, within which pedagogical and research perspectives were anticipated. The strands thus represent key issues that are crucially embedded in the activity of problem solving, whether in teaching or learning mathematics, both within the school and beyond the school.

Technology, creativity, and affect in mathematical problem solving were the main focuses of a research project conducted in Portugal over the past three years, under a grant from the Portuguese funding agency, Fundação para a Ciência e Tecnologia. This research project, in devoting particular attention to web-based mathematical competitions, in line with the growing acceptance and importance attributed to this type of initiative all over the world, set itself the goal of sharing results, ideas, conclusions and developments achieved along its course, through a scientific meeting with interested colleagues from other countries.

The scientific programme thus gravitates around the three thematic strands, offering four plenary talks given by prominent researchers from different parts of the world and three keynote addresses proposed by members of the Portuguese Problem@Web research team followed by invited reactors' comments, but it simultaneously took in mind to encourage and welcome submissions of research papers and e-posters. Our sincere thanks are due to the plenary speakers and to the invited reactors who generously accepted to enrich the conference with their insightful inputs.

It is our pleasure to have reached the final program with 27 peer-reviewed research papers and 8 e-posters, distributed across the three strands of the conference, attaining a good solid body of work that filled the three days of the conference. We want to compliment all the authors for their relevant perspectives, and we are in debt to all the reviewers who kindly and thoroughly collaborated in revising and improving the proposals, under a process of open peer-reviewing. All this contributed to the high quality of the final published papers in the conference proceedings.

The conference proceedings are offering an overview of all the research presented in the form of plenary sessions, research papers and e-posters. This conference aims to be the seed of future developments, in particular, allowing the gathering of researchers who join and gain momentum for the preparation of a post-conference book that pushes research forward on issues discussed during the three days of work and debate. Therefore the plenary sessions, including both the lectures from invited authors and the keynote addresses in each of the conference strands, were seen as starting points for

the development of further publishable material and their abstracts are offered in the conference proceedings as the authors' approaches to the conference key issues. The research papers are fully published in the proceedings and represent a substantial part of its content, organized under the three strands of the conference, according to the authors' own intention of inclusion of their work in a particular strand. Moreover, the e-posters are summarized as short one-page articles and also connect to one or more of the conference strands. Altogether, these proceedings combine multiple perspectives and ways of addressing and relating technology, creativity and affect, three promising development directions in the current research on mathematical problem solving.

One last word of recognition is due to the University of Algarve and to the Institute of Education of the University of Lisbon, which jointly promoted this event, contributing with their invaluable support to the organization.

Susana Carreira, Nélia Amado, Keith Jones, and Hélia Jacinto

PLENARY LECTURES

MATH PROBLEM, INTERNET AND DIGITAL MATHEMATICAL PERFORMANCE

Marcelo Borba

State University of São Paulo, Brazil

“If production of knowledge is understood in this way, what constitutes a “problem” will depend on the nature of the humans-with-media collective. A problem that needs to be solved, or that puzzles someone, may not be a problem when a search software tool like Google is available. Similarly, a real problem for collectives of humans-with-orality may not constitute a problem for a collective of humans-with-paper-and-pencil.” (Borba, 2012, p. 804).

In this talk I will unpack the above quote from a recently published paper on ZDM. I will discuss first the way Internet and mobile telephones in particular, and digital technology in general, are changing the nature of what means to be a human being (Castells, 2009; Borba, 2012). In order to do this I will present the notion of production of knowledge that emphasize the role of different technology throughout history (Levy, 1993; Villareal & Borba, 2010). I will briefly discuss how different artifacts such as the blackboard are important for the development of education and how notions such as demonstrations are embedded in media such as paper-and-pencil. I will summarize the four phases of the use of digital technology in mathematics education (Borba, 2012) in order to discuss the notion of digital mathematical performance.

I will next discuss a perspective regarding the notion of “problem” in which problem is seen as having an objective and subjective aspect, respectively an obstacle to be overcome and an interest in overcoming such an obstacle. In doing so, I will argue that a problem change depending on the media is available, in other words how different collectives of human-with-media (Borba & Villarreal, 2005) relate to different obstacles, and how they may become a problem or not to such a collective.

Having discussing the notions of humans-with-media and problem, I will bring such a discussion to the classroom. I will show how a simple function activity may be a problem for collectives of humans-with-paper-and-pencil, but not for a collective of humans-with-Geogebra. Could calculate a given integral be a problem for some students in the math classroom? I will argue that availability of wolphram alfa is a good starting point for such a discussion.

I will show these different examples showing how digital technology has evolved and how it has brought different possibilities of problems and how it has transformed “old problems” in mere “exercises”.

Finally I will discuss if we should or should not admit Internet in the classroom (Borba, 2009) and I will show how I am believe Internet can be admitted in the classroom. I will show how video, facebook and regular software can create different possibilities

for learning in the regular classroom and on the “online classroom”. In particular I will discuss the notion of digital mathematics performance, showing how it brings together the fourth phase of the use of technology, arts and mathematics. I will argue that Digital mathematics performance “may be the future” of what problem means for a student. Text book problems may be out! Digital Mathematics Performance may be in! Discussion will be stimulated about whether Internet will be admitted in the classroom, or whether the classroom will be dissolved in the Internet.

REFERENCES

- Borba, M.C. (2012). Humans-with-media and continuing education for mathematics teachers in online environments. *ZDM Mathematics Education*, 6(44) p. 801-814.
- Borba, M. C. (2009). Potential scenarios for Internet use in the mathematics classroom. *ZDM Mathematics Education*, 41(4), 453–465.
- Borba, M. C., & Villarreal, M. E. (2005). *Humans-with-media and the reorganization of mathematical thinking: information and communication technologies, modeling, visualization, and experimentation*. New York: Springer.
- Castells, M. (2009). *Communicating Power*. London: Oxford University Press.
- Levy, P. (1993.) *As Tecnologias da Inteligência: o futuro do pensamento na era da informática*. Rio de Janeiro: Editora 34.

ROLES OF AESTHETICS AND AFFECT IN MATHEMATICAL PROBLEM SOLVING

Norma Presmeg

Illinois State University (Professor Emerita), United States of America

My goal in this presentation is to tease out some of the significant aspects of both aesthetic sense and affective issues in the solving of non-routine mathematical problems. Both aesthetics and affect are under-researched domains in mathematics teaching and learning (Sinclair, 2004, 2008). Yet there is ample evidence from the personal experience of teachers of mathematics of the motivational effect of an “Aha!” moment experienced by a student in solving a mathematical problem, and of the pleasure that such an experience afforded. And research mathematicians frequently speak of the aesthetic elements involved in their work, for instance of the beauty of an elegant proof (Burton, 2004). Thus it would appear that aesthetic sense is a significant issue in the learning and doing of mathematics, and worthy of further research attention. Especially, as in the case of the non-routine problem solving involved in the Algarve Project, when students are not under compulsion to solve the mathematics problems, what is it that gives them the motivation to do so, and to persist in the face of difficulty in order to reach a solution?

I start with a vignette of a high school teacher who was particularly aware of the aesthetic elements of mathematics, and who stressed these in his teaching. This teacher was especially adept at helping his students to make connections in their learning of mathematics, between different topics, but also in linking aesthetic and cognitive processes. After that I address some theoretical formulations of ‘the aesthetic’, taken from both the arts and the sciences, and analyse differences between aesthetics and affect: these are intimately connected, but they are not the same because they function differently in problem solving processes (Sinclair, 2008). And there is evidence that both are also intimately connected to the cognitive domain. For instance, Presmeg and Balderas-Cañas (2001) describe the case of Ms. Blue, an elementary school teacher, whose meta-affect (affect about affect: Goldin, 2000) so paralyzed her thinking that she was not able even to enter the first sense-making stage of solving three non-routine problems presented to a group of graduate students.

Continuing with empirical data from the same project, three further cases of non-routine problem solving are presented, each of which gives evidence of a more productive affective pathway than that of Ms. Blue. In these three cases, despite difficulties, the students were able to persist and arrive at solutions to the problems by various methods. Visual aspects of aesthetic sense are examined. In several cases the patterning aspects of aesthetic sense resulted in metaphoric thinking that had the potential to be fruitful and to overcome some of the affective states, such as discouragement, that threatened to derail the problem solving processes. Some

examples of metaphors that were ultimately fruitful are presented, resonating with the work of Carreira (2001) in connection with mathematical models.

Connections, patterns, and metaphors are recurring themes in my research that related to affect and to aesthetics. I present a brief vignette from the case of Sam, whose initial compartmentalization prevented him from solving a trigonometric problem involving an angle in the second quadrant; I report his elation when he finally connected the unit circle and the graph of a sine function.

Finally in gathering results from further empirical studies, I describe the work of Sinclair (2001) in devising a color-coding calculator whose aim was to encourage free problem solving associated with aesthetic elements, as middle school students worked with fraction patterns in individual interviews. Sinclair's research was specifically targeted to aesthetic elements, affect, and motivation in the mathematics learning of young students. She identified not only the difficulties associated with research on these "ephemeral" topics, but also their importance, and potential to make a difference in encouraging students to continue with the subject of mathematics. I close with suggestions for further research that might prove fruitful.

REFERENCES

- Burton, L. (2004). *Mathematicians as enquirers: Learning about learning mathematics*. Dordrecht: Kluwer.
- Carreira, S. (2001). Where there's a model, there's a metaphor: Metaphorical thinking in students' understanding of a mathematical model. *Mathematical Thinking and Learning*, 3(4), 261-287.
- Goldin, G. A. (2000). Affective pathways and representation in mathematical problem solving. *Mathematical Thinking and Learning*, 2, 209-219.
- Presmeg, N. C. & Balderas-Cañas, P. E. (2001). Visualization and affect in nonroutine problem solving. *Mathematical Thinking and Learning*, 3(4), 289-313.
- Sinclair, N. (2004). The roles of the aesthetic in mathematical inquiry. *Mathematical Thinking and Learning*, 6(3), 261-284.
- Sinclair, N. (2008). Aesthetics as a liberating force in mathematics education. *ZDM: The International Journal of Mathematics Education*, DOI 10.1007/s11858-008-0132-x. Accessed 25 January, 2014.

THE CURRICULUM, CREATIVITY AND MATHEMATICAL COMPETITIONS

Jaime Carvalho e Silva

University of Coimbra, Portugal

Mathematical Creativity has been discussed first with some detail by Henri Poincaré and Jacques Hadamard at the beginning of the 20th century. The journal “L'Enseignement Mathématique” has published an inquiry in 1902 trying to discern the mathematical work; one of the questions was “Avez-vous cherché à vous rendre compte de la genèse des vérités, découvertes par vous, auxquelles vous attachez le plus le prix?” (Volume 4, p. 209).

Nevertheless it was not discussed with much detail until recent years (Leikin, Pitta-Pantazi, 2013). Now it is considered to be very important at different levels. In Korea it is considered to be so relevant that “Creativity and Character building” is one of the main directions of the 2009 national curriculum revision. In this curriculum it is even considered to be important for all the students and not only for some (more gifted or more intelligent): “For all the students, not for the talented only”. Of course this policy faces considerable challenges, namely the assessment tools and the grading methodology that are being modified in Korea to accommodate assessment of creativity. Another issue is teacher preparation and so the Ministry developed model schools and created study groups for creativity/ character education. A formidable challenge.

It will be argued that mathematical competitions can be one of the main tools to foster Mathematical Creativity in the school system. For this, the main types of mathematical competitions, its goals and its modus operandi will be reviewed. We will compare classical Mathematical Olympiads with more recent types of competitions like the Mathematical Kangaroo (Kangourou sans frontières) and the Mathematical Contest in Modeling (MCM).

We will also discuss and try to classify competitions involving technology, online competitions, competitions made individually or in groups, and different kinds of competitions with mathematical games.

We will call for a systematic exploration of different kinds of mathematical competitions in order to develop different aspects of mathematical creativity for different kinds of students in different grades. A competition like the “Math Video Challenge” is designed with the goal of getting students to develop their creativity and communication skills. Can it be classified as a major tool for that, or other types of competitions are close or more efficient at the development of Mathematical Creativity? How may we be able to analyze the different types of competitions from this perspective?

REFERENCES

- Commission Internationale de l'Enseignement Mathématique (1902). Enquête sur la méthode de travail des mathématiciens. *L'Enseignement Mathématique*, 4, 208-211.
- Kim, J. S. (2013). The Relevance of Creativity and Innovation: Korean Curriculum Revision Case. *CERI/OECD - Educating for Innovation in Asia: Theory, Evidence and Practice*. 15-16 January 2013. Singapore. Retrieved from http://www.oecd.org/edu/ceri/02%20Jin%20Sook%20Kim_Korea.pdf.
- Leikin, R. & Pitta-Pantazi, D. (2013). Creativity and mathematics education: the state of the art. *ZDM*, 45, 159–166.
- Sriraman, B. (2004). The characteristics of mathematical creativity. *The Mathematics Educator*, 14(1), 19–34.

MULTIPLE SOLUTION PROBLEMS IN COMPUTERIZED AND NON-COMPUTERIZED ENVIRONMENTS: WHAT DIFFERENCE DOES IT MAKE?

Michal Tabach

Tel Aviv University, Israel

In recent years the mathematical education community's attention towards creative mathematical thinking has increased considerably. Liljedahl and Sriraman (2006) suggest that creative mathematical thinking for mathematicians is "the ability to produce original work that significantly extends the body of knowledge" or "opens up avenues of new questions for other mathematicians" (p. 18). However in the context of school mathematics, one can hardly expect that a students' contribution will be at that level. Hence, the idea of relative mathematical creativity is more in order. Mathematical creativity in school may be evaluated with respect to students' previous experiences and performances of their peers (Leikin, 2009).

Relativity is also relevant when considering mathematical problems. Schoenfeld (1989) defined a mathematical problem as "a task (a) in which the student is interested and engaged and for which he wishes to obtain a resolution; and (b) for which the student does not have a readily accessible means by which to achieve that resolution" (pp. 87–88). Leikin (2009) claims that an explicit request for solving a problem in multiple ways may be used for eliciting students' creative mathematical thinking and as a mean for evaluate it.

Three multiple solution problems were assigned to two fifth grade classes from the same school. One class worked regularly in a technological environment while the other did not. The presentation will relate to methodological questions regarding the evaluation of students' solutions. Researchⁱ findings will be reported and discussed.

ⁱ The research was conducted in collaboration with Dr. Esther Levenson and Riki Swisa.

REFERENCES

- Leikin, R. (2009). Exploring mathematical creativity using multiple solution tasks. In R. Leikin, A. Berman & B. Koichu (Eds.) *Creativity in Mathematics and the Education of Gifted Students* (pp. 129-35). The Netherlands: Sense Publishers.
- Liljedahl, P. & Sriraman, B. (2006). Musings on mathematical creativity. *For The Learning of Mathematics*, 26(1), 20-23.
- Schoenfeld, A. H. (1989). Teaching mathematical thinking and problem solving. In L. B. Resnick & L. E. Klopfer (Eds.), *Toward the thinking curriculum: Current cognitive research* (pp. 83-103). Alexandria, VA: Association for Supervision and Curriculum Development.

PANEL

PRESENT AND FUTURE ROLES OF ONLINE MATH COMPETITIONS IN THE EDUCATION OF TWENTY-FIRST CENTURY YOUNG STUDENTS

João Pedro da Ponte*, Keith Jones**

* Institute of Education, University of Lisbon, Portugal, ** University of Southampton, United Kingdom

With this panel, we intend to exchange ideas and hear the perspectives of several people who, in different ways and at some stage, have been connected to the web-based mathematical competitions Sub12 and Sub14, held by the Department of Mathematics, of the Faculty of Sciences and Technology of the University of Algarve.

We invite to bring in his/her own personal perspective: a former participant in the competitions because it will allow us to appreciate what such experience meant to his learning of mathematics and the importance it had in his academic and personal life; the mother of a former participant who has followed, for several years, the involvement of his son in the competitions and was beside him at the Finals, in order to knowing her vision with respect to parental involvement in these competitions, comprising the inclusiveness and educational purposes they embrace; a mathematics schoolteacher, who has supported several of her students throughout the various editions of the competitions, inside and outside the classroom, to hear her testimony on the advantages taken from their participation for mathematics learning and how she sees the role of the school in face of those and other beyond-school activities.

As an introductory topic, we will offer a possible characterization of the young participants in the competitions, which was based on the results of the implementation of an online survey in 2012, in all schools of the Algarve, targeting students from 5th to 8th grades, whether or not participating in these competitions.

Our challenge is to provide a multiple glance over the role of web-based mathematical competitions on the mathematics education of 21st century children and consider future developments of this kind of projects.

Invited Members of the Panel:

Ana Cristina Bacalhau Coelho, mother of a former participant in the competitions.

Bruno Pedrosa, former participant in the competitions, currently graduate student of Medicine.

Dora Nunes, Mathematics Teacher at the Group of Schools Padre João Coelho Cabanita, Loulé, Algarve.

Eugénia Castela, collaborator of the Problem@Web Project, Faculty of Economy, University of Algarve and CIEO.

KEYNOTE ADDRESSES

THE USE OF DIGITAL TOOLS IN WEB-BASED MATHEMATICAL COMPETITIONS: DEGREES OF SOPHISTICATION IN PROBLEM SOLVING-AND-EXPRESSING

Hélia Jacinto*, Sandra Nobre*, Susana Carreira**, Nélia Amado**

* Research Unit of the Institute of Education of the University of Lisbon, Portugal;

** University of Algarve and Research Unit of the Institute of Education of the
University of Lisbon, Portugal

Reactor: João Filipe Matos, Institute of Education, University of Lisbon, Portugal

The technological e-permeated society where we live (Martin & Grudziecki, 2006) has made it possible to enlarge the frontiers of mathematics learning, which once were confined to the classrooms in each school (Gee, 2004; Shaffer, 2006). The immersion in the digital world seems to be changing the way young people perceive and act on the environment that surrounds them (Prensky, 2001; Tapscott, 1998; Veen & Vrakking, 2006).

Recently, the research community has recognized the importance of extracurricular activities in which youngster are becoming increasingly involved, demonstrating a growing interest in studying this involvement and its potential benefits, namely by looking at how it may stimulate formal mathematics learning, or by assessing the impact of curricular learning in life beyond the classroom (Barbeau & Taylor, 2009; Jacinto & Carreira, 2012; Wijers, Drijvers Jonkers, 2010).

All over the world, several organizations have nurtured the development of students' problem solving abilities by organizing competitions and tournaments of different kinds. This is the case of the Mathematics Competitions Sub12 and Sub14, promoted by the Department of Mathematics of the Faculty of Sciences and Technology, University of Algarve, addressing students from grades 5 to 8 (10-14 year-olds) in the south of Portugal. A trademark of these two extracurricular competitions is its inclusiveness during the Qualifying as they develop entirely through the Internet and the participation model allows young people with different mathematical abilities to develop their relationship with mathematics and problem solving. To each of the ten problems given, it is required that the participants explain their problem solving process and find ways to express their thinking and their strategies. They may use any of the digital tools they have at their disposal and find useful for solving a given problem.

The research we have been developing has uncovered the aptitudes of young competitors to take advantage of everyday digital tools and its representational expressiveness to give form and substance to their own reasoning and the construction of a solution strategy (Carreira, 2012; Jacinto & Carreira, 2013). Another emerging aspect is the perception of the existence of different degrees of robustness of the

solutions submitted, mainly in terms of the conceptual models that competitors develop, with a particular technological tool, to solve the problems.

Here we will analyse a selection of solutions submitted to two problems, in which competitors resort to Excel, in one case, and to GeoGebra, in the other. We present a proposal for identifying levels of sophistication and robustness of technology-based solutions to the problems, based on an inspection of the characteristics of the tool use and its connection to the conceptual models underlying students' thinking on the problems.

ACKNOWLEDGMENTS

This work is supported by national funds through Fundação para a Ciência e Tecnologia, under the project PTDC/CPE-CED/101635/2008 and the research grants SFRH/BD/69917/2010 and SFRH/BD/73363/2010.

REFERENCES

- Barbeau, E. & Taylor, P. (Eds.). (2009). *Challenging Mathematics In and Beyond the Classroom. The 16th ICMI Study*. New York, NY: Springer.
- Carreira, S. (2012). Mathematical problem solving beyond school: digital tools and students mathematical representations. *ICME 12*, pp. 2933-2942. Seoul: ICMI.
- Gee, J. (2004). *Situated Language and Learning. A critique of traditional schooling*. New York, USA: Routledge.
- Jacinto, H., & Carreira, S. (2012). Problem solving in and beyond the classroom: perspectives and products from participants in a web-based mathematical competition. *ICME 12*, pp. 2933-2942. Seoul: ICMI.
- Jacinto, H., & Carreira, S. (2013). Beyond-school mathematical problem solving: a case of students-with-media. In A. Lindmeier, & A. Heinze (Eds.). *Proceedings of the 37th Conference of the IGPME*, Vol. 3, pp. 105-112. Kiel, Germany: PME.
- Martin, A., & Grudziecki, J. (2006). DigEuLit: Concepts and Tools for Digital Literacy Development. *Innovation in Teaching and Learning in Information and Computer Sciences*, 5(4), 249 -267.
- Prensky, M. (2001). Digital Natives, Digital Immigrants. *On the Horizon*, 9(5), October, (n/p.). NCB University Press.
- Shaffer, D. (2006). *How computer games help children learn*. New York: Palgrave Macmillan.
- Tapscott, D. (1998). *Growing up digital: The rise of the Net generation*. New York: McGraw-Hill.
- Veen, W. & Vrakking, B. (2006). *Homo Zappiens: Growing up in a digital age*. London: Network Continuum Education.
- Wijers, M., Jonker, V., & Drijvers, P. (2010). MobileMath: exploring mathematics outside the classroom. *ZDM*, 42(7), 789–799.

HIGHLIGHTING CREATIVITY IN CHILDREN'S BEYOND-SCHOOL MATHEMATICAL PROBLEM SOLVING

Nuno Amaral*, Susana Carreira**

* Escola Básica 2,3 Sophia de Mello Breyner Andresen, Lisbon, Portugal,

** University of Algarve and Research Unit of the Institute of Education, University of Lisbon, Portugal

Reactor: Isabel Vale, School of Education, Polytechnic Institute of Viana do Castelo, Portugal

Many learning opportunities which are taking place beyond the classroom should in no way be neglected and should instead be seen as a valuable counterpart of the school curriculum and school-based learning (Harrison, 2006). Solving mathematics problems, in particular, is definitely established as an activity that may extend beyond the mathematics classroom and give rise to children's engagement with mathematics and mathematical thinking. The knowledge and experience gained outside school are expected to extend, diversify and enhance the mathematical knowledge typically retained from school-based learning, while being likely that one boosts the other.

The importance of studying students' problem solving activity outside the classroom, especially when the problems are related to mathematical concepts, is highlighted by several researchers (e.g., English, Lesh & Fennewald, 2008; Barbeau & Taylor, 2009). On the other hand, encouraging and valuing mathematical creativity can be one of the purposes set out in different contexts of mathematical activity, which are not restricted to the classroom (Applebaum & Saul, 2009). Thus, looking at the mathematical creativity involved in solving problems outside the classroom appears as a suitable research avenue.

The desire to compete and overcoming challenges is deeply rooted in human nature and has been used for centuries to help people improve their skills and performance in various activities (Kenderov, 2006). Thus, given that the classroom is no more than one of the possible contexts of the educational process, it is important to draw attention to the impact and benefits of competitions related to mathematics education, including those that take place beyond the school.

Among many world-wide flourishing projects, the SUB12 Competition promotes mathematical problem solving beyond the classroom. Running in Portugal since the academic year 2005/2006, this web-based mathematical competition addresses students in 5th and 6th grades (10-12 year-olds), aiming to develop their enthusiasm and appreciation for moderate mathematical challenges. The competition problems are in line with a variety of problem solving approaches where students can develop concepts pertaining to diverse areas of school mathematics. This competition offers

students the opportunity to think for themselves, to come up with their own strategies and reasoning, as well as to activate knowledge and develop different representations in their search for a solution (Gontijo, 2006). It requires participants to submit and explain the entire process carried out to achieve the solution, including all of the reasoning developed in the clearest possible way. It provides a considerable amount of time, which is sometimes missing in the classroom due to the need to comply with the curriculum and other school work restrictions, thus allowing students to be more creative. Therefore it turns out to be a significant environment for the development of creativity and independent thinking, where students can display their talent and sometimes solve problems in unexpected and innovative ways (Taylor, Gourdeau & Kenderov, 2004). The freedom students have to think mathematically on each problem allows them to discover interesting ways of solving problems, often translated into unusual solutions (Ching, 1997).

Within our research project, we seek to detect evidence of mathematical creativity in students' proposed solutions to the problems posed in the SUB12 competition, partly motivated by the fact that a good number of solutions received within the online competition have been regarded as amazing solutions in light of what is expected of young children's mathematical background.

Thus, the main purpose of our research is to describe and characterise the mathematical creativity in young students' solutions to mathematics problems, within their participation in the SUB12 competition. To this end, we have been developing and gradually improving a framework of analysis aiming to highlight specific dimensions of mathematical creativity in the ways students solve and express their solutions to mathematical problems. This framework has already been applied to some of our empirical data showing that mathematical creativity in problem solving may take many different shades and revealing that creative solutions mirror the presence of different indicators of creativity (Amaral & Carreira, 2012).

In this way, we intend to increase the awareness about mathematical creativity and its relation to the expression of mathematical thinking through problem solving, seeking to identify observable indicators of creative mathematical reasoning (Saundry & Nicol, 2006). At the same time, we want to understand the extent to which online and digital environments like the SUB12 can add to the creativity found in activities such as mathematical problem solving that is in the end relevant to school mathematics.

In this talk we will present some of the efforts heading for a way of characterizing students' creative solutions to mathematical problems, in a competitive situation aiming for inclusiveness and which takes place beyond the classroom.

ACKNOWLEDGMENTS

This work is supported by national funds through Fundação para a Ciência e Tecnologia, under the project PTDC/CPE-CED/101635/2008.

REFERENCES

- Amaral, N., & Carreira, S. (2012). An essay on students' creativity in problem solving beyond school – proposing a framework of analysis. In *Pre-Proceedings of the International Congress on Mathematical Education (ICME 12) – Topic Study Group 3*, Seoul, 8-15 July 2012, (pp. 1584-1593).
- Applbaum, M., & Saul, M. (2009). Anecdotes and assertions about creativity in the working mathematics classroom. In R. A. Berman & B. Koichu (Eds.), *Creativity in Mathematics and the Education of Gifted Students* (pp. 272-284). Rotterdam: Sense Publishers.
- Barbeau, E. J. & Taylor, P. J. (2009). Preface. In E. J. Barbeau & P. J. Taylor (Eds.), *Challenging Mathematics In and Beyond the Classroom. The 16th ICMI Study*, (pp. 97-131). NY: Springer.
- Ching, P. (1997). An experiment to discover mathematical talent in a primary school in Kampong Air. *ZDM-International Journal on Mathematics Education*, 29(3), 94-96.
- English, L., Lesh, R. & Fennewald, T. (2008). Future directions and perspectives for problem solving research and curriculum development. Paper presented at the *11th International Congress on Mathematical Education (ICME11) – Topic Study Group 19: Research and development in problem solving in mathematics education*. Retrieved from <http://tsg.icme11.org/document/get/458>.
- Gontijo, C. H. (2006). Estratégias para o desenvolvimento da criatividade em matemática. *Linhas Críticas*, 12(23), 229-244.
- Harrison, C. (2006). Postmodern research and e-learning: anatomy and representation. *European Educational Research Journal*, 5(2), 80-93.
- Kenderov, P. S. (2006) Competitions and Mathematics Education. In M. Sanz-Solé, J. Soria, J. L. Varona & J. Verdera (Eds), *Proceedings of the International Congress of Mathematicians* (pp. 1584-1598). Universidade Castilla - La Mancha, Spain.
- Saundry, C., & Nicol, C. (2006). Drawing as problem-solving: young children's mathematical reasoning through pictures. In J. N. H. Moraová, M. Krátká & N. Stehlíková (Eds.), *Proceedings of the 30th Conference of the International Group for the Psychology of Mathematics Education* (Volume 5, pp. 57-63). Prague, Czech Republic.
- Taylor, P., Gourdeau, F., & Kenderov, P. (2004). The role of mathematical competitions in mathematics education. In M. Niss (Ed.), *Proceedings of the 10th International Congress on Mathematical Education* (pp. 495-497). Roskild University, Denmark.

THE AFFECTIVE RELATIONSHIP OF YOUNGSTERS AND PARENTS WITH MATHEMATICS AND PROBLEM SOLVING IN INCLUSIVE MATHEMATICAL COMPETITIONS

Nélia Amado*, Susana Carreira*, Eugénia Castela**, Rosa Antónia Ferreira***

* University of Algarve and Research Unit of the Institute of Education, University of Lisbon, Portugal, ** University of Algarve and CIEO, Portugal, *** University of Porto and CMUP, Portugal

Reactor: Guida de Abreu, Oxford Brookes University, United Kingdom

The school and, in particular, the classroom, were for many decades the main place for learning. The information and communication technologies and specially the advent of the Internet gave rise to new forms of learning and, as such, research in mathematics education is facing new challenges. In recent years, new places for learning, beyond the classroom, have emerged (Kenderov, Rejali, Bussi, Pandelieva, Richter, Maschietto, Kadijevich & Taylor, 2009), sparking young people's interest and the attention of researchers. In Portugal, the interest for mathematics learning beyond the school is still recent; however, internationally, this topic has received particular attention from several organizations affiliated to the International Commission on Mathematics Instruction. This and other activities aim to give students the opportunity to get in touch with exciting mathematics, seeking to motivate them to learn this subject or giving them the chance to learn more mathematics. The increasing participation of young students in mathematics competitions, mathematics clubs, mathematics days, summer schools and other similar events (Kenderov et al., 2009) should not be regarded as a sign of weakness of the classroom; rather, it should be seen as additional opportunities for new and diverse learning, which may contribute to improving students' school achievement.

Following the previous Keynote Addresses, we will focus on affective issues involved in the Mathematical Competitions Sub12 and Sub14. These competitions, which have an inclusive character, are centred on solving challenging mathematical problems (Turner & Meyer, 2004). National and international studies (e.g., Kenderov et al, 2009; Wedege & Skott, 2007, Jacinto & Carreira, 2011) have suggested that these activities, taking place beyond the classroom, can promote a positive relationship of students with problem solving and, furthermore, an affective connection of youngsters and their families with mathematics (e.g., Carreira, Ferreira & Amado, 2013).

Adopting a five-dimension perspective on affect – beliefs, attitudes, emotions, values, and feelings (Selden, McKee, & Selden, 2010) – we will intentionally focus on the beliefs, attitudes and emotions in the context of the aforementioned inclusive competitions, from the point of view of young participants and of their families. The

results are supported by data collected through a questionnaire administered at the end of the 2011/2012 edition of the Sub12 and Sub14 competitions to the students of the Algarve region which participated in those competitions. Data were also collected through several semi-structured interviews to the participants and their families. At some points we will draw on the content of exchanged emails with the participants along the competitions to illustrate occasional affective aspects expressed by them.

Data analysis has suggested that the inclusive character of the competitions relates to the affective dimensions involved in the youngsters' participation, as well as a significant influence on their adherence to mathematics and problem solving.

The empirical data show that the participants involved in these mathematical competitions are not necessarily gifted students. In fact, a considerable number of participants may be considered average-ability students. We believe that the high level of participation of youngsters in this type of beyond school mathematics activities is also a result of the freedom that characterizes Sub12 and Sub14; such freedom is three-fold: participants have a considerable amount of time to solve each problem; participants are free to choose whatever approach they prefer to solve each problem; participants are left the choice of resources, namely technological resources, to solve and express their problem solutions.

Our research results further indicate that the participants recognize two different kinds of mathematics, a school mathematics and a beyond school mathematics. In addition, the data reveal that participating in those competitions promotes a positive view regarding mathematics and problem solving, leading also to an improvement of mathematics learning in school.

Finally, we will address how the students' participation in these mathematics competitions spread out to their families, arousing and involving several emotions and unveiling beliefs about mathematics.

ACKNOWLEDGMENTS

This work is supported by national funds through Fundação para a Ciência e Tecnologia, under the projects PTDC/CPE-CED/101635/2008 and PEst-C/MAT/UI0144/2013, and by FEDER funds through COMPETE.

REFERENCES

Amado, N. & Carreira, S. (2013). O contributo da participação numa competição matemática para a aprendizagem de um aluno com necessidades educativas especiais: o caso de Rui. In J. Fernandes, M. H. Martinho, J. Tinoco & F. Viseu (Orgs). *Atas do XXIV Seminário de Investigação em Educação Matemática* (pp. 529-542). Braga: APM & CIE, Universidade do Minho

- Carreira, S., Ferreira, R., & Amado, N. (2013). Young students solving challenging mathematical problems in an inclusive competition: enjoyment vis-à-vis help-seeking. In B. Ubuz, Ç. Haser & M. A. Mariotti (Eds.) *Proceedings of the Eight Congress of the European Society for Research in Mathematics Education* (pp. 1289-1298). Ankara, Turkey. ISBN 978-975-429-315-9.
- Jacinto, H. & Carreira, J. (2011). Nativos digitais em atividade de resolução de problemas de matemática. Conferência Online de Informática Educacional. Lisboa, UCP. Retrieved from <http://www.coied.com/2011/atividades/artigos/tema1/>.
- Kenderov, P., Rejali, A., Bussi, M. G., Pandelieva, V., Richter, K., Maschietto, M., Kadijevich, D., & Taylor, P. (2009). Challenges beyond the Classroom – Sources and organizational issues. In E. J. Barbeau & P. Taylor (Eds.), *Challenging Mathematics In and Beyond the Classroom: The 16th ICMI Study* (pp. 53-96). New York, NY: Springer.
- Selden, A., McKee, K., & Selden, J. (2010). Affect, behavioural schemas and the proving process. *International Journal of Mathematical Education in Science and Technology*, 41(2), 199–215. doi:10.1080/00207390903388656.
- Turner, J., & Meyer, D. (2004). A Classroom Perspective on the Principle of Moderate Challenge in Mathematics. *Journal of Educational Research*, 97(6), 311-318.
- Wedegé, T., & Skott, J. (2007). Potential for change of views in the mathematics classroom? In D. Pitta-Pantazi & G. Philippou (Eds.), *Proceedings of the Fifth Congress of the European Society for Research in Mathematics Education* (pp. 389-398). Larnaca, Cyprus. Retrieved from <http://ermeweb.free.fr/CERME5b/>.

RESEARCH PAPERS

DIGITAL STORYTELLING FOR IMPROVING MATHEMATICAL LITERACY

Giovannina Albano, Anna Pierri

Dipartimento di Ingegneria Elettrica, Ingegneria dell'Informazione e Matematica Applicata – University of Salerno, Italy

galbano@unisa.it; apierri@unisa.it

This paper focuses on the use of digital storytelling in order to improve students' capabilities be active solvers of real world problems. We present a storytelling model which takes into account both research results for storytelling in pedagogical research and for story problems in mathematics education research, posing them in the PISA framework in mathematics. At the end of the theoretical presentation of the model, a case of use is presented, which is going to be delivered to 13-15 year-old students in the schools of Campania (south of Italy).

INTRODUCTION

In this paper we present the work of an ongoing project, called “Obiettivo 500”, funded by the Regional School Office of Campania in the South of Italy. The project is devoted to 13-15 year-old students and aims at improving their mathematical literacy (in the sense of PISA) and thus at helping them be successful at the next PISA 2015. The project works in blended mode, that is some teaching/learning activities are going to be performed in face-to-face setting, and other ones are going to exploit new technology features and potentialities in distance setting. Our work is posed in the latter strand. Following the PISA framework in mathematics, which views the student as an active problem solver in front of a challenge in real world, our work focuses on the exploitation of digital storytelling in mathematics education to improve the student's capabilities to face and solve such challenge. To this aim we have defined a storytelling design model which takes into account both pedagogical and mathematics education research results and PISA framework. At the end, a case of use of our model is presented, which is being implemented and it is foreseen to be delivered to the students at the end of next March.

THEORETICAL BACKGROUND

Mathematical competencies in the PISA framework

The core of the PISA 2015 mathematics framework is the definition of *mathematical literacy*, which comes out from a fundamental actual requirement: what does a citizen need in order to face daily situations involving mathematics? The answer consists in

an individual's capacity to formulate, employ, and interpret mathematics in a variety of contexts. It includes reasoning mathematically and using mathematical concepts, procedures, facts and tools to describe, explain and predict phenomena. It assists individuals

to recognize the role that mathematics plays in the world and to make the well-founded judgments and decisions needed by constructive, engaged and reflective citizens (OECD, 2013, p. 5).

Thus the student is viewed as an active problem solver. This definition puts emphasis on the need of developing the students' capability of using mathematics *in context*, but this requires to plan lessons rich of experiences able to engage the students in reaching such abilities. Moreover, it is well-experienced that students are much more motivated when they have the chance to see the applications of mathematics to out-of-school contexts.

The above definition highlights from the beginning the main mathematical processes needed to individuals in order to connect the context of a problem with mathematics, making them able to solve the problem. Let us see in more details:

- *Formulate* situations mathematically, that is the ability of translating a problem from the real world to the domain of mathematics, then giving the problem a mathematical structure and representation;
- *Employ* mathematical concepts, facts, procedures and reasoning, that is the ability of performing mathematical procedures in order to have outcomes and to find mathematical solutions to the problems;
- *Interpret*, applying and evaluating mathematical outcomes, that is the ability of thinking on mathematical solutions, outcomes or conclusions, and of interpreting them in the context of real-world problems, evaluating the meaningfulness and the reasonableness with respect to the context of the problem.

PISA experiences have shown that there is a set of fundamental mathematical capabilities underpinning the described processes in practice. Literature shows the various examples of recognition of such general mathematical capabilities (OECD 2013, p. 12). The PISA framework referred, until now, to Niss work (2003), using what Niss called *competencies*. The PISA 2015 framework refers to Turner work (2012), which condenses the number of the competencies from eight to seven: communication, mathematizing, representation, reasoning and argument, devising strategies for solving problems, using symbolic, formal and technical language and operations, using mathematical tools. For each of the previous fundamental mathematical capabilities, six levels of proficiency can be devised, according to the observation that increasing activation of fundamental mathematical capabilities is associated with increasing level of mastering of mathematical literacy by an individual (Turner & Adams, 2012).

Narrative and logical-scientific thinking in story problems

Bruner (1986) distinguishes two (complementary, even if irreducible) thoughts: the logico-scientific one, which “attempts to fulfil the ideal of a formal, mathematical system of description and explanation”, and the narrative one, which “leads to good stories, gripping drama, believable (though not necessarily “true”) historical accounts [and] deals in human or human-like intention and actions and the vicissitudes and consequences that mark their courses” (pp. 11-13).

Story are not popular in mathematics classrooms; most mathematics classroom instruction consists of short explanations by the teacher followed by a series of examples that students then imitate in their own work. Even when a problem solving is involved it is seldom accompanied by a story (Zazkis & Liljedahl, 2008).

The main stages in problem solving are the *representation* (understanding the problem) and the *solution*. With this respect, there will be information relevant to representation, called by Zan (2011) *narratively relevant*, and information relevant to the solution, that is to answer the question, called by Zan (2011) *logical relevant*.

The benefit of bringing storytelling into a mathematics classroom is the capability to introduce or explain hard concepts in a memorable fashion and involve students in mathematical activity. Thus a story problem could be conceived as a mathematical problem which has been contextualised in concrete and realistic situations, familiar to the student with respect to her life experience. Then the representation stage should recall the student's encyclopaedic knowledge which should be the basis of the solution stage. Teachers' experiences show that often students fails in story problems and it seems that the story does not help them, as expected. Zan distinguishes the failure in the two previous stages: in the first one, the student puts herself in the "mathematics context", thus she does not give any attention to the story and just searches for "numerical/mathematical" data; in the second one, the student looses herself in the story and then does not activate logical-scientific thought.

The key point faced by Zan is then how narrative thinking can *support*, through the process of representation of the story, the logical thinking in the solution process. Zan's hypothesis is that

it is important that information needed for the representation be consistent from the logical point of view, in particular consistent with the posed question (Zan, 2011, p. 8).

Based on this assumption, Zan (2012) proposes a Context and Question (C&D) model for the construction/formulation of the text of a story problem, which consists in the following requirements:

- *There is a story*: there is a situation evolving along time, and there is at least an animated actor;
- *There is a natural link between the story and the posed question*: there is an actor having a goal, which is not immediately reached, and the mathematical problem naturally arises from the context (i.e. it is not artificially introduced);
- *The story is well-structured*: the various parts of the text are linked from the narrative standpoint and the information and details have sense in the narrative context;
- *The solution is consistent with the goal*: the answer to the considered question is necessary for the character to achieve his goal.

THE METHODOLOGY

In this section we illustrate the methodology considered for creating digital storytelling addressing mathematical capabilities starting from real world contexts.

So, in the first subsection the design of the Storytelling Model is presented; the second subsection contains the adaptation of the Storytelling Model to the PISA mathematics framework.

The Storytelling Design Model

The Storytelling Design Model (SDM) is based on the notion of Visual Portrait of Story (VPS) defined by Raymond & Ohler (2008). The VPS represents a time-diagrammatic view of the most emotionally important moments of a narrative, which are summarized in the following list:

- **Elements of a beginning (call to adventure).** The story begins by moving out of the flat, ordinary events of life to new heights of experience. For instance, information that ground the listener in the ordinary life of a character or group of characters is presented. A hero or main character is *called to adventure* in which the ordinary routine of life is interrupted. A quest of some kind is described or begun. The listener understands that the main character, perhaps with help from others, needs to accomplish something or to go somewhere.
- **Elements of a middle (conflict, consisting of problem/solution, tension/resolution).** The full extent of the tension, problem or conflict is made apparent. The tension is increased through the use of situations that beg for some kind of resolution. We can have a series of such situations in which the characters, through failure, persistence and personal growth, finally achieve a goal.
- **Transformation (middle, continued).** The key to transformation is that the central character (or group) cannot solve the problem of the story easily or simply; she/he needs to change in order to do it. If the central character does not undergo some sort of transformation on the way to solving the problem, then the listeners are dissatisfied, often cheated upon their listening experience. For instance, the main character needs to be transformed in order to solve the problem or achieve resolution. She/he needs to become stronger, smarter, wiser, more mature or some combination of these.
- **Elements of an end (closure).** Stories need to have the endings that allow the listeners to feel as though their personal investment in listening has not been in vain. For instance, stories can finish in an obvious way, such as stating what has been learned in the form of a moral or personal revelation. Conversely, stories can move forward with some action that clearly shows what learners have internalized.

Figure 1 illustrates the phases of the VPS correlating them to the tension degree during the story (Raymond & Ohler, 2008).

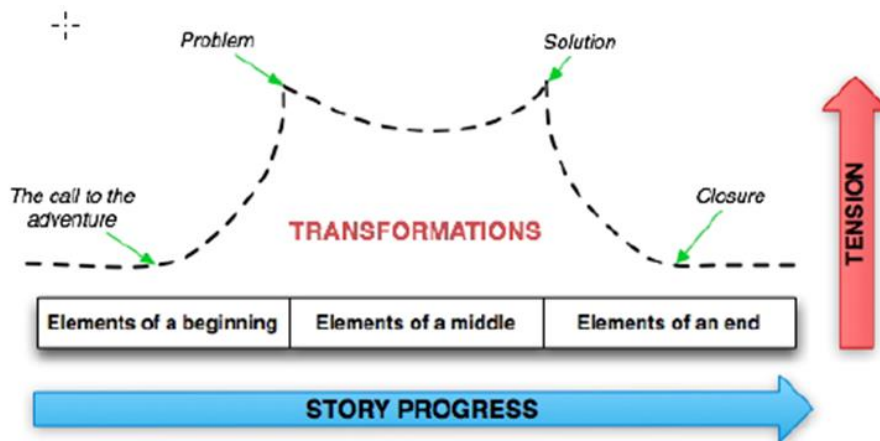

Figure 1. Phases and tension function of the Visual Portrait of Story.

There are two tension picks. The first one is related to the time when the problem raises. The second one is related to the moment when the problem is solved. In the process of traversing the path from problem to solution, the student learns, grows and becomes a new person in some significant respect.

VPS is an approach to flash out the story core with story details guiding the development of story-based didactic resources. The defined SDM exploits the concept of *transformation formations*, i.e. the transformation of characters. The characters can undergo different kinds of transformation.

The literature (Ohler, 2006) identifies eight levels of transformations in a story map: *Physical/kinesthetic, Inner Strength, Emotional, Moral, Intellectual, Psychological, Social and Spiritual*. The levels are not mutually exclusive, therefore the characters often transform themselves at more than one level at the same time.

The Storytelling Design Model aims to fill the lacks of existing storytelling models by providing ways of:

- empowering pedagogical drivers during the storytelling definition phase, in order to connect storytelling situations and events and achieve specific levels of educational goals;
- exploring branching logic in order to design micro-adaptivity mechanisms by using indications coming from data recovered from implicit assessment to define remedial paths tailored to meet the learner's learning progress;
- enhancing the character-based approach by defining role playing, taking and making strategies in order to support telling, re-telling and re-living;
- supporting cognitive transformations by exploiting collaborative and social learning activities in order to maximize role making strategy.

This methodology has already experimented in other context (as in the ALICE¹ European Project). Through the combination of guided, objectives oriented and adaptive process the methodology contributes to improve learning of the students that have a predisposition to the experiential learning by demonstrating, in such a way, as this didactic method is suitable to the transmission of lesson learned.

The methodology takes into account different hypothesis of validation needed for experimenting the use of the storytelling learning resource. They concern the following analysis:

- The use of Storytelling Learning Objects (SLOs) contributes to improve students' motivation and emotional status.
- The use of SLOs contributes to support instructors' task.
- The use of SLOs contributes to increase students' activity levels, both in individual and collaborative activities.
- The use of SLOs contribute to improve students 'understanding of key concepts as well as related skills.

The Mapping between the SDM and PISA's levels

The proposed model considers the *intellectual transformations* as changes in terms of learning goals. At this level of transformation, the learners (who lead the characters) are asked to use intellectual-creative abilities in order to solve a problem. In particular, the SDM proposes an extension to the association between Bloom's Taxonomy (Bloom, 1956) and character transformations in order to map each transformation with a specific phase of the VPS. In Table 1 a mapping among VSP situations, Bloom's learning goals and characters' transformations has been presented. In particular, Bloom's hierarchy of transformation, identifies a taxonomy of *intellectual changes* in terms of *six different levels of learning goals*, that are considered in increasing order of difficulty, from basic to higher levels of critical thinking skills (Mangione, Orciuoli, Pierri, Ritrovato, Rosciano, 2011).

Table 1. Mapping among VPS situations, learning goals and character transformations.

VPS Situations	Bloom's Learning Objectives	Type of Transformation
Beginning	Knowledge	Character knows, remembers or describes something
The call to adventure	Comprehension	Character explains, interprets, predicts something.
Problem	Application	Character discovers, constructs or changes something; applies understanding to a new situation.
Middle	Analysis	Character deconstructs a situation, distinguishes among options, plans or organizes something, compares and contrasts different things.
Solution	Synthesis	Character pieces together parts to form a new understanding of a situation.
Closure	Evaluation	Character assesses a situation, critiques and/or defends an idea (or a person,...) and evaluates a situation in order to respond to it.

Each VPS situation includes the following event:

- **advancer event**, that is designed to activate the prior knowledge of the student and ensure their initial involvement in the situation;
- **learning event**, that supports the learner's understanding of topic goal and it is based on a guided approach;
- **reflection event**, that is designed to help the learner to reflect on learned concepts and to allow them to consolidate the acquired knowledge;
- **assessment event**, that submits to learners a test (with respect to the specific VPS situation in which the learner is involved) for evaluating the type of transformation occurred.

An assessment event presents a selection of assessment modes through the arrangement of different types of tests and items with different levels of interactivity and complexity in order to detect different learners' abilities during the storytelling path. For instance, true/false questions are useful to acquire mnemonic knowledge elements, multiple-choice questions can be exploited to evaluate the ability of understanding, problems to solve are needed to evaluate the ability to apply resolving procedures, matching questions should be used to evaluate the ability of the learner to identify and separate elements of knowledge, to highlight relationships that bind them and the general organizational principles and laws.

Starting from the Bloom's taxonomy, we have associated to each Learning Objectives, a specific Competence's Level, that corresponds to the acquisition of skill or attitude in the mathematics context (OECD, 2013, p.27):

- at level 1, students are able to work in familiar context and to manage direct and clear information and questions, and they can realize procedures of direct instructions;
- at level 2, students are able to work in context requiring no more than one direct inference, to manage only one representations and they can perform elementary procedure and direct interpretation of outcomes;
- at level 3, students are able to apply simple strategies, manage more than one source of information and make some reasoning, and they can edit brief reports of the results, reasoning, interpretations;
- at level 4, students starting to be able to manage complex concrete situations, coordinating more representation and having flexibility and capability of discovering in contexts already known;
- at level 5, students are able to model complex situations and to identify assumptions and constraints, they can develop advanced strategies and manage adequately more source of information and representations, and they can reflect on their actions and communicate their thinking;

- at level 6, students are able to conceptualize, generalize and use information based on his own analysis, to coordinate various sources of information and representation, they can perform advanced mathematical thinking and reasoning.

Each competence's level can be associated to each SDM phase starting from the association of Level 1 to the first SDM's phase "Ordinary life" until Level 6 associated to the final phase "Life resumes...". The right associations is obtained taking into account the skills necessary to acquire the considered level.

So, considering the mapping between the Bloom's Learning Objects and the VPS situations (Mangione, Orciuoli, Pierri, Ritrovato, Rosciano, 2011; Mangione, Capuano, Orciuoli, Ritrovato, 2013), we state the following associations shown in the following figure.

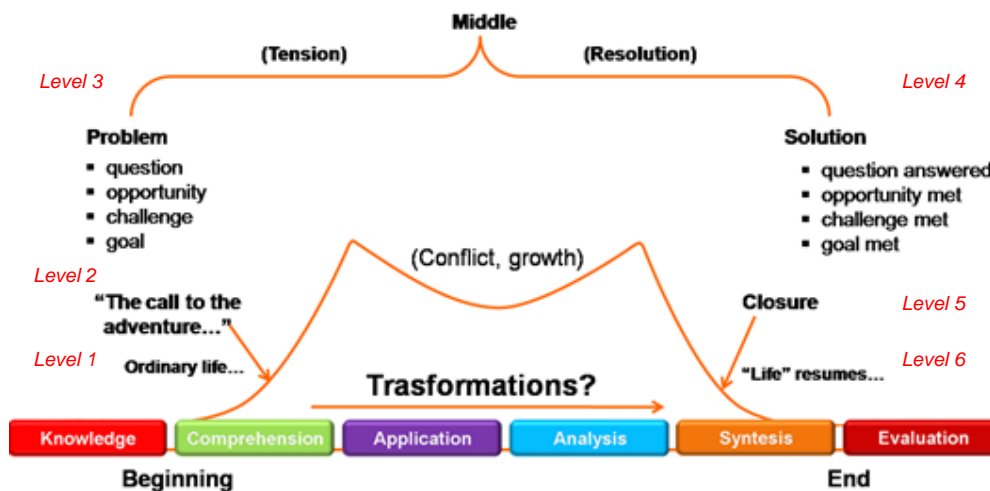

Figure 2. Competences' level with respect to the Storytelling' phases

THE CASE OF USE

The project "Obiettivo 500" aims to promote and enhance the fundamental mathematical capabilities using a storytelling based approach. The use of advanced digital contents in the form of "stories" encourages the involvement and the student's attention, thanks to overcoming the technological generation gap, and thus becomes an instrument "effective" through which transforming "complex knowledge" and encourage significant and profound understanding.

In the following a first use case is going to be described. The design of the story moved according to the C&D model of Zan (2012). So we designed a story evolving along the time, whose main character is a student, who has an explicit goal. The problem naturally arises from the goal and the goal can be reached by solving the problem.

As Duval (2006) pointed out, mathematical activities are characterized by the massive use of multiple representations and the conceptualization is strictly linked to the ability of handling at least two different representations of the same object moving from one to another at any time. This is the so-called coordination of the representations which is the core of the comprehension. Duval states that such coordination is not spontaneous

but it requires teaching/learning activities aimed to foster the students to systematically explore and observe the possible variations of a representation within a given system of representation and among various systems. This is why storytelling seems to be a good methodology to improve students' ability.

The learning goal

The case of study is focused on one of the fundamental mathematical capabilities, the "representation".

From PISA 2015 the representation is so defined:

this mathematical capability is called on at the lowest level with the need to directly handle a given familiar representation, for example going directly from text to numbers, or reading a value directly from a graph or table. More cognitively demanding representation tasks call for the selection and interpretation of one standard or familiar representation in relation to a situation, and at a higher level of demand still when they require translating between or using two or more different representations together in relation to a situation, including modifying a representation; or when the demand is to devise a straightforward representation of a situation. Higher level cognitive demand is marked by the need to understand and use a non-standard representation that requires substantial decoding and interpretation; to devise a representation that captures the key aspects of a complex situation; or to compare or evaluate different representations (OECD, 2013, p. 31).

Considering the three mathematical processes, shown in the Section 1, we can adapt them to the representation's capability (OECD, 2013, p.15). More in depth we intend the mathematical processes as follow:

- *Formulate*: the student is able to create a mathematical representation of real-world information;
- *Employ*: the student is able to articulate a solution, show the work involved in reaching a solution and/or summarise and present intermediate mathematical results;
- *Interpret*: the student is able to construct and communicate explanations and arguments in the context of the problem.

The story

We suppose that a student is involved in a stage having for objective the acquisition of the *journalist's* title. Considering the mapping in the Figure 4, we detail the storytelling's phases for our context.

Situation 1: Ordinary life

In this situation, the student demonstrates a basic knowledge of the different types of charts examined. During the *advancer event* he attends a presentation of the course in "Graphical Representations" and takes part in a scenario where two journalists are working in the interpretation of graphs prediction of election results by communicating the wrong messages to the general public causing the derision of larger parties and the

illusion among smaller ones. During the *learning event*, the focus is the understanding of the existence of various types of diagrams and the importance of knowing, for example, to quickly switch from text to numbers, or usefulness of reading a value directly from a graph or table. The *reflection event* serves as organizer of the key concepts to remember. Finally, the *assessment event* presents the student with a first round of evaluation in order to help people understand the levels of knowledge input.

Situation 2: The call to the adventure

In this situation, the student demonstrates ability to understanding/reading considered graphs in a specific context. The *advancer event* presents to the student the opportunity to take part in an important service to be carried out in conjunction of the regional elections. In particular, a special communication, referred to as aberrant communications, must be built for substituting these with real information that journalists promote on the basis of interpretations of data and graphical representations not properly modeled and interpreted. The student, during the *learning event*, must follow the point of view of the protagonist and understand how to read charts considered in a specific context of the specific newspaper and reproduce the correct message to the hypothetical viewer. The *reflection event* shows to the student the newspapers inefficiency to convey the correct information to the readers, highlighting the inadequacy of graphics selected for the scope or the misinterpretation made by journalists to communicate specific information which turn to be well away from the actual results. Finally, the interpretation of multiple charts semi-structured and guided (to complete a text with multiple distractors) characterizes the *assessment event*.

Situation 3: The problem

In this situation, the student must demonstrate ability to use representations based on information from different sources. The *advancer event* involves the student in writing an essay on a survey done on the parliamentary elections. The student accesses to four examples of situations in which, during the *learning event*, we show how to solve a problem by using representations from different sources. The student interacts with these scenes simulated and select the most suitable explanation. The *reflection event* proposes a trailers on the actions he performed during learning with a focus on the erroneous explanations. Finally the *assessment event* ask students to consider specific types of graphs (such as scatter plot or bubble) to represent the details necessary for the preparation of the test and then asked to complete a written text unstructured.

Situation 4: The solution

In this situation, the student must demonstrate the ability to compare and evaluate the information. Once done with practical problems, the *advancer event* asks the student to evaluate three audio video interviews of the three candidates of the majority parties. Each candidate exhibits from his point of view, what are the updated data of the campaign. The student, during the *learning event*, learns the translation mode of a situation in two or more different representations.

Situation 5: Closure

The student must demonstrate the ability to reflect and communicate their interpretations of the data. The event draws attention to the student's introduction to the three major political bloggers on the interview and on the graphs represent the views of individual parties with respect to the performance of the voting. The *assessment event* asks the student to carry out an essay / piece of journalism. The student must use some words in free text by inserting them in a certain order. Visual feedback that shows only the logical accuracy of communication is associated with a qualitative judgment.

Situation 6: “Life resumes....”

In this final phase, the student is expected to demonstrate through a summative test their newly acquired skills for the analysis of graphical representations proposing new situations, that as a journalist may find that they need to manage. In the *advancer event* the student is asked to undergo a final test in order to be included in the official lists of employees and possibly be called to work for the realization of particular pieces of journalism. In the *assessment event*, the final test for journalistic qualification must demonstrate that they have acquired during the internship period the ability to connect different forms of information and representations passing from one to another in a flexible manner.

As we can observe, some situations are not completely described in the specific (see from Situation 4 to Situation 6), since the development of the storyboard is and ongoing activity.

CONCLUSIONS AND FUTURE WORKS

In this paper we have presented an ongoing work, which focuses on the exploitation of digital storytelling for improving mathematical literacy. A new model is presented, which takes into account pedagogical features of storytelling and mathematics education research concerning story problems and fundamental mathematical capabilities. Based on such model, a first storytelling is being implemented, focused on the representation skill, and it is foreseen to be delivered to the students at the end of next March. This first delivery will help to test and adjust the model, since further implementations of storytelling are planned in the framework of the project “Obiettivo 500” in order to cover all the seven fundamental mathematical capabilities.

NOTES

1. <http://www.aliceproject.eu/>.

REFERENCES

Bloom, B. S., & Krathwohl, D. R. (1956). *Taxonomy of Educational Objectives: The Classification of Educational Goals, by a committee of college and university examiners, Handbook I: Cognitive Domain*. New York: Longmans Green.

- Bruner, J. (1986). *Actual minds, possible worlds*. Cambridge: Harvard University Press.
- Duval, R. (2006). The Cognitive Analysis of Problems of Comprehension in the Learning of Mathematics. *Educational Studies in Mathematics*, 61(1), 103-131.
- Mangione, G. R., Orciuoli, F., Pierri, A., Ritrovato, P., & Rosciano, M. (2011). A new model for storytelling complex learning objects. *International Workshop on Adaptive Learning via Interactive, Collaborative and Emotional Approaches, in conjunction with the Third International Conference on Intelligent Networking and Collaborative Systems* (pp. 836-841). Fukuoka: IEEE.
- Mangione, G. R., Capuano, N., Orciuoli, F., & Ritrovato, P. (2013). Disaster Education: a narrative-based approach to support learning, motivation and students' engagement. *Journal of e-Learning and Knowledge Society*, 9(2), 129-152.
- Niss, M. (2003). Mathematical competencies and the learning of mathematics: The Danish KOM project. In A. Gagatsis, & S. Papastavridis (eds.): *3rd Mediterranean Conference on Mathematical Education* (pp. 116-124). Athen: Hellenic Mathematical Society.
- OECD (2013). *PISA 2015 Draft Mathematics Framework*. OECD. Retrieved from <http://www.oecd.org/pisa/pisaproducts/Draft%20PISA%202015%20Mathematics%20Framework%20.pdf>.
- Ohler, J. (2006). The world of digital storytelling. *Educational leadership*, 63(4), 44-47.
- Ohler, J. & Raymond S. (2008). Digital Storytelling in the Classroom: New Media Pathways to Literacy, Learning, and Creativity. *Computers and Composition*, 25 (4), 449-452.
- Turner, R. (2012). Some drivers of test item difficulty in Mathematics. *Annual Meeting of the American Educational Research Association*. Vancouver: AERA. Retrieved from <http://research.acer.edu.au/pisa/4/>.
- Zan, R. (2012). La dimensione narrativa di un problema: il modello C&D per l'analisi e la (ri)formulazione del testo. *L'insegnamento della matematica e delle scienze integrate*. 35 A.
- Zan, R. (2011). The crucial role of narrative thought in understanding story problems. In K. Kislenko (ed.) *Current State of Research on Mathematical Beliefs. XVI Proceedings of MAVI-16 conference*, pp. 287-305. Tallin, Estonia: Tallinn University, Institute of Mathematics and Natural Sciences.
- Zazkis, R., & Liljedahl, P. (2008). *Teaching mathematics as storytelling*. Thousand Oaks, CA: Sage Publications.

USING STATISTICAL SOFTWARE IN BASIC EDUCATION: DIFFICULTIES AND AFFORDANCES

Cláudia Fernandes*, João Pedro da Ponte**

* Agrupamento de Escolas Manuel Teixeira Gomes, Portimão; ** Instituto de Educação, Universidade de Lisboa

claudiapcfernandes@gmail.com, jpponte@ie.ul.pt

The aim of this study is to analyze the benefits and problems associated to the use of statistical software TinkerPlots in grade 7 and its consequences to teachers' practice. The research methodology is qualitative and interpretative, with a teaching experiment design and data collected from video recorded classes and interviews. The results show that there are (i) benefits in using this tool in statistics teaching, given its possibilities for the manipulation of graphics, stimulating students' conceptual understanding, (ii) difficulties in students' work, both in using the software and in interpreting statistical concepts and representations; and (iii) difficulties in the teacher's professional practice, in managing the class in a new situation and in issues related to knowledge of content and of the software.

INTRODUCTION

Technology is a very versatile resource for the classroom work. The use of statistical educational software allows dealing with sets of data of any size, quickly and efficiently, leaving time for exploratory data analysis and discussion so necessary for understanding concepts and progressing in learning. The development of technology yielded a new way of teaching statistics, focusing attention in concepts and not on computations (Martins & Ponte, 2010). This is clearly a resource that motivates students for classroom work and fosters their involvement in the proposed tasks. Teachers need to know to take advantage of this possibility. The software TinkerPlots allows exploratory work in statistics in an easy and intuitive way. This paper aims to analyze the problems associated to the use of this software, as well as the affordances that it may provide in the framework of a teaching experiment with grade 7 students.

USE OF TECHNOLOGY IN THE TEACHING OF STATISTICS

Several reasons may lead a teacher to consider the use of technology in statistics classes: (i) facility in representing and manipulating data; (ii) possibility to give emphasis in the understanding of concepts instead of focusing attention in computational procedures; (iii) possibility to undertake exploratory and investigation tasks, promoting its discussion in the classroom; (iv) possibility of using these tasks to promote awareness of the role of statistics in society associated to the development of statistical thinking; and (v) students' motivation for this kind of work.

In the statistics class, technology may be regarded as a tool to be used by teacher and students, in different ways. Two of them are of high interest for this study – the construction of graphs and computing statistics and using simulations. The quick elaboration of graphs and the efficiency in obtaining statistics allows using more time for interpreting situations and solving problems. Pratt, Davies and Connor (2011) indicate that the work with simulations, based on mathematical models, allows students to develop a vision of what the reality may be providing them the experience of working with distributions. Martins and Ponte (2010) consider that using simulations based on technological resources a valuable process for getting a sense for statistical concepts and to understand variability, a key idea in statistics. The power of using this kind of software lies in creating graphs or simulations and is related to the possibility of making a dynamical control of data, especially in the case of distributions with many elements. Such distributions may be quickly handled using these tools, providing students the opportunity to explore cases using different representations (Lee & Hollebrands, 2011; Rubin & Hammerman, 2006).

The visualization of graphical representations using statistical software allows a detailed exploration of data, leading to the creation of different representations and different questions and conjectures, as well as to different interpretations. As Rubin and Hammerman (2006) indicate, regardless of the available tools, data analysis requires contrasting distributions and patterns presented by variables. They argue that TinkerPlots may support students to represent and explicit their reasoning and these representations may be then used to support group discussions.

The use of technological resources allows the classroom activity to focus on students, with the teacher assuming the role of promoting and leading learning situations. As students' autonomous work goes on, the teacher needs to monitor what is going on, which is a rather complex task. Exploratory work may lead students to follow strategies and find results that the teacher did not foresee and this requires a solid knowledge of statistics as well as of the software. Likewise, the diversity of the situations that may emerge during whole class discussions requires the teacher the capacity to conduct them. During discussions, the teacher selects the students' mathematical ideas to present, sequences students' interventions and facilitates communication asking students to expose these ideas (Stein, Engle, Smith, & Hughes, 2008). Also for Connor, Davies and Holmes (2006), solving exploratory tasks in groups and then participating in whole class discussions sharing experiences and negotiating meanings is a way of work that supports students' learning. Rubin and Hammerman (2006) highlight that teachers need to understand the key value of interactions among the tools used, the underlying culture, and the mathematics argumentation in the classroom. In their view, that is fundamental so that students relate classroom discussions to contextual knowledge ascribing meaning to the task.

Ponte, Mata-Pereira and Quaresma (2013) present a model of analysis of whole class discussions focusing on the teacher's actions. In this model, inviting actions provide the initial involvement of students in a discussion. In supporting/guiding actions the

teacher promotes students' continued participation in solving a problem, leading them in a discrete or explicit way through questions or other interventions. In informing/suggesting actions the teacher provides information or validates students' responses, thus assuming the primary responsibility for the mathematical discourse. In challenging actions the teacher leads the students to think, explain or justify their responses. In addition, other teachers' actions are mostly geared to the management of learning. There are many pedagogical aspects that influence the management of communication, particularly with regard to the initiation and maintenance of mathematical discussions as a normal class activity. In addition, the use of technology is another factor to consider in managing the classroom environment.

METHODOLOGY

This study was conducted in 2012/13 in a grade 7 class of a public school at the Algarve. The class includes 24 students (13 boys and 11 girls) aged between 12 and 14, which, in general, show difficulties, little autonomy, and lack of working habits, preferring to work individually rather than in groups. The tasks proposed in the statistics teaching unit were exploratory and were solved using TinkerPlots. These tasks followed the curriculum guidelines and sought to take into account the interests of students and their prior learning. As such, they focused on the study of some of the students' characteristics, with data collected by them. Each task included a script for the use of the software since this was the first time that the students were manipulating this tool. Based on the different situations proposed and using the software, the students should make conjectures and come to their own conclusions. This software is appropriate to their age level, allowing for very easy and intuitive graphical representations of data in various ways. At the same time it allows to find values of measures of location and dispersion, enabling students to obtain these representations rather than knowing how to compute, so that they have the opportunity to interpret the meanings of these measures in the contexts described.

The teacher played the role of a guide, leaving room for students to progress at their own pace. Each task was introduced by the teacher, through a short presentation, followed by class time devoted to autonomous work which varied depending on the degree of complexity of the task. As foreseen in the lesson plan, the students worked in pairs or groups of three, each group having access to a computer with TinkerPlots. For each task, there was also a whole-class discussion, then a final synthesis. The communication process was based on sharing ideas, and the teacher's role was to help students, leading them to learn mainly by reflective activity. The explanatory function was shared by teacher and students. The statistics unit had six lessons that were videotaped and students' written records were collated.

The teaching experiment included the realization of six tasks. The first tasks aimed primarily at familiarizing students with the software, especially the graphical representation of different chart types and obtaining absolute and relative frequencies. This initial phase of the experiment proceeded without major difficulties. In this paper

we analyze what occurred in the final tasks that had a higher degree of complexity. In each episode we highlight the potential use of this software in the classroom and the difficulties found in terms of students' work and on the teacher's professional practice. We also strive to show the decisions taken by the teacher in the face of unforeseen situations.

TASK 5

This task was intended to provide students an opportunity to work with location and dispersion measures using the variable age of students in the class in months. Since, at this stage, students had already a reasonable mastery in manipulating this software, the teacher guided them to work autonomously from the beginning of the task.

1. Starting with the birth dates of the different students in this class, we calculate the age of each student in months and organize the information in a table. This indicates age in months and the absolute frequency for each age, as you had the chance to check.
 - a) Based on the data in the table, draw a dot plot that represents information correctly.
 - b) Compute the mean and median age of the group (in months).
 - c) What is the age of the oldest student? And of the youngest?
 - d) Compute the amplitude of ages in the class.
 - e) Construct, using Tinker Plots, a box plot that represents this data set. Prepare a short text that explains this graphical representation.

Task 5: "I'm younger than you!"

The students built the intended dot plot quickly and organized the information. They called the teacher, while she circulated among the tables, asking her to confirm their work:

Ricardo: Teacher, is this correct?

Teacher: It's correct. (...) So tell me, what is the most common age in the class?

Ricardo: Here it is! There are three. (*The student correctly interpreted the graph after arranging the points properly using the control buttons*)

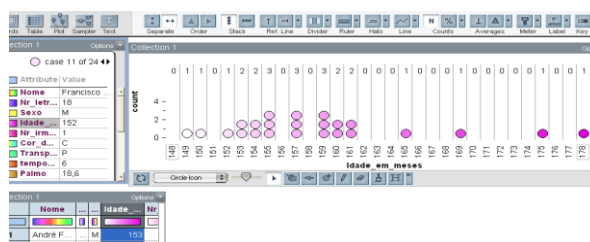

Figure 1. Task 5 - Solution.

In this episode, the teacher validated the student's answer, indicating that he was correct. She also guided the continuation of the work raising a question to focus the student's attention in interpreting the chart. The student lived up to the expectation and read the graph correctly answering the teacher's questions.

Then, the teacher guided the students to continue working on the concepts of mean and median, interpreting them in the context of the situation. As the students used the button to get the mean, the teacher further guided their work asking:

Teacher: And now what happened?

Ricardo: A triangle appeared here ... It is showing a value here...

By asking this question the teacher wanted to see if the students identified the change on the graph with the introduction of a new symbol that located the mean and its value so that they could continue working. Her objective was achieved because the question helped the students to focus their attention and to identify the changes depicted on the graph.

As the students found the values of the location measures, the groups interacted with each other, trying to confirm the values that they got. At this stage, some problems emerged, such as the students' difficulty in the graphical interpretation of the values of the mean and the median or the different results found by different groups, because of several mistakes:

Mariana: Teacher! What is the result?

Teacher: (*Approaching*) What you are computing? Do you have the average?

Mariana: This is the average. Here is our result! The median is not... Isn't like theirs... They have that number...

Teacher: (*Approaches the other group*) Show me! Oh! It is because you selected only a small part of the points and then you computed the mean and the median only for that part instead of computing for all of the data.

Sometimes the students seemed to feel the need to carry out computations instead of interpreting the values that they had got. The teacher, without undermining the importance of numerical computation, insisted on the interpretation, and later exemplified the computation:

Jorge: Teacher, this is just to indicate the mean and the median? What about the computations?

Teacher: The TinkerPlots already computed. Now I'd like you to tell me how it computed it. (...) Tell me, what was the value of the mean and the median?

Students: The median is 157 and the mean is 158.6.

Teacher: (*Notes in the black board*). This appeared in TinkerPlots. It's convenient and quick, but if you didn't have the software, how would you do this? (...) How can we obtain the mean through a table with data organized? For example, if

we wanted to know the mean of the tests of each of you, how would you do to mean?

Carlos: We sum all the tests and then divide by the number of tests.

Teacher: So, how does TinkerPlots get the mean age in months?

Mariana: It added everything and divided by the number of...

Ricardo: Students.

In this episode the predominant form of teacher action is supporting/guiding. She noted that the students just read the values on the graph. Aiming to recall and reinforce students' concept of mean, the teacher draw on a sample known to students so that they establish a connection between ideas. This strategy successful and the students managed to show understanding of the notion of mean.

The last question referred to the construction of a box plot. The students were building this diagram for the first time and the teacher, once again, emphasized the importance of interpreting in the final discussion of the task. In the following episode we identify a negotiation of meanings as the teacher throws in the discussion an unknown terminology (box with whiskers) with the intention of focusing on the shape of the diagram. The students, based on the notion that the "whiskers" are usually symmetric, made this observation and the teacher took the opportunity to inform/suggest that this asymmetry is due to how the data is distributed:

Teacher: You did the box plot using TinkerPlots. It looks like a box with whiskers doesn't it?

Ricardo: Whiskers?

Teacher: If you look at the diagram.... It has some tips...

Ricardo: (*Noticing that the graph is not equally distributed*) Yes, only the whisker is poorly done. One side is longer than the other.

Teacher: Because the data are not distributed in the same way.

Once end values and quartiles were identified and their graphical interpretation was made, the teacher addressed the notion of distribution. She asked for the interpretation of the diagram but noted some difficulties in students. In consequence, she decided to guide students focusing their attention on the division into quartiles:

Teacher: Where do you think there is a greater concentration of data? (...) It is... between quartile 1 and quartile 2, or between quartile 2 and quartile 3...?

Carlos and Ricardo: Between quartile 1 and quartile 2.

Teacher: Why?

Carlos: Because that's where there's more.

Teacher: More what?

Mariana: Dots.

The support given by the teacher was effective because the students were able to identify the parts of the diagram where the data were more concentrated and to justify their choice.

The use of TinkerPlots in this task was beneficial, not only for finding quickly and efficiently the graphics and the location and dispersion measures, but also to address the notion of statistical distribution. The students themselves compared the points in the graph and the boxplot to understand how the data was distributed. Later, they made other conclusions regarding the specific context of the class.

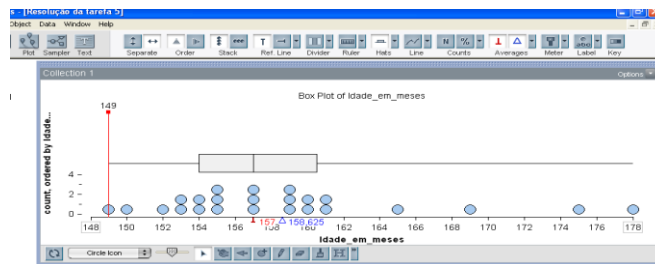

Figure 2. Solution of task 5 regarding measures of location and dispersion.

TASK 6

This task aimed at working the notion of probability in an intuitive way, based on the notion of relative frequency. The task was a simulation and took 50 minutes to do. The variable under attention was the favorite flavor of ice cream of the students in the class. The task proposed the following simulation scenario:

1. Each of the students of our class responds to an inquiry about what ice cream flavor was preferred among five possible flavors: Strawberry (S), Chocolate (CH), Vanilla (V), Cream (CR), and Lemon (L).
 On a very hot day all students in the class decided to go to Vilamoura's marina to have ice cream. Each student asked their favorite flavor. Mr. Ramos, the owner of the ice cream store, greeted them cheerfully, and made them an offer:
 - Good afternoon! Our store is celebrating today its 10th anniversary and, because of that, the ice creams are on the house, provided the consumer accepted playing a little game that we are proposing. Do you accept?
 The students all agreed and Mr. Ramos continued:
 - So, each of you asks an ice cream cone with your favorite flavor and goes out for a walk in the marina with the ice cream in one hand and five cards on the other hand. Each of the cards has the letters of each of the ice cream flavors (S, CH, V, CR, or L). When you find the first person, you must ask him or her to choose one of the cards. If the person hit the taste of the ice cream that you have in your hand you should offer this person your ice cream, otherwise you can eat it: (As it is impossible to perform this experiment in real life, we use the Tinker Plots and simulate this situation to realize what could happen).
2. Based on the simulation carried out, answer the following questions:
 - a) How many students lost their ice cream?
 - b) What percentage of students lost his ice cream after playing?
 - c) What was the most chosen flavor ice cream on the cards?

Task 6. “Who eats icecream?”

The students were confused with the results of the simulation. The teacher decided to encourage a whole class discussion, beginning with a question that challenged them to interpret the results. The teacher undertook this action because the students were following the statement of the task and carrying out the simulation, but were not interpreting the results as she expected.

Teacher: What happened?

Mariana: (...) The numbers of students appeared in face of the flavors of ice cream.

Teacher: (...) So what happened? It appeared a new table?

Diva: With our tastes?...

André: No! I did not choose this!

Roberto: Teacher ... I think it's what other people have chosen...

Teacher: That's it! Roberto is right. That's right. So let's see what happened to each of you. Who ate the ice cream and who does not eat ice cream?

By challenging students to interpret what happened, the teacher initiated a discussion that led them to interpret the results. After reaching this goal the teacher validated the students' findings, stating that they were correct and supporting/guiding them to the next stage.

Following the directions given in the statement, the students created a table showing the column of their choices alongside the column of choices that the simulation generated for each student. Some conclusions began immediately emerging, and the teacher validated some opinions in order to encourage the students to pursue:

Teacher: Daniela is saying “I ate”... Why Daniela?

Daniela: Because the computer is saying “strawberry” but I chose vanilla.

Teacher: Because Daniela's computer says that the person who spoke to Daniela chose strawberry and she chose vanilla.

Each group conducted a simulation on a different computer and found a different set of results due to the randomness of the experience. The teacher did not inform the students on purpose and let them to try to understand the situation. As this stage, she adopted predominantly supporting/guiding and informing/suggesting actions as the students showed to be somewhat confused by the disparity in results between the different groups:

Ricardo: But here, she chose lemon and the lady she spoke chose... Cream.

Teacher: You chose what Daniela?

Daniela: I chose vanilla!

Barbara: Here was strawberry!

Carlos: And here it was vanilla.

Teacher: Look, vanilla! Then Daniela did not eat ice cream!

Daniela: So? I ate or did not eat?

Elix: No. Here is “C” Chocolate.

Teacher: So the person who Daniela found, in Elix’s computer, chose chocolate...
What happened then?

André: They are different options.

Mariana: This is a simulation.

Realizing that the students were reasoning in the intended direction the teacher changed her strategy, assuming a challenging position, trying to lead students to figure out the meaning of simulation. So she launched a simple question urging students to continue autonomously:

Teacher: And... ?

Carlos: You may have various situations.

Mariana: (...) If it were another time, we could find someone else who chose something else.

The goal of the teacher was achieved. Using an informal language the students expressed the notion of simulation. The teacher then informed them of the validity of their conclusions:

Teacher: What is happening is that this computer is a simulation... It is random (...) So, getting different results is normal.

Afterwards, the students created a column in the table where they compared the results for each student obtaining the information for who would have eaten or offered the ice cream, by introducing a formula. Given the greater complexity of the task, some minor difficulties arose due to mistakes made in the introduction and interpretation of the formulas, as the students were not familiar with these processes. As the table setting out the comparison was achieved, the teacher posed again a challenging question, requesting an interpretation of results:

Teacher: What’s up?

Mariana: Look, teacher! Almost everyone eats!

The teacher took advantage of the observation made by the student and returned to challenge students with a new question. The intention of the teacher was to get students to go further in the exploration, comparison and interpretation of results:

Teacher: Almost everyone eats. Why is that?

Beatriz: Oh, only numbers 19 and 21 have to give the ice cream.

Elix: Here it isn’t like that!

Mariana: Here there are four people who give the ice cream.

Teacher: How many people give their ice cream?

Mariana: Four... three in their group.

Jorge: I count two.

In response to this challenge from the teacher, the students made comparisons between the results obtained in the different groups, fulfilling the goal of the teacher. The contextualized nature of the task helped the students' interpretation, since they were able to associate the results to a real situation. The teacher bypassed the problem of the diversity of results found in the simulation in a whole class discussion where the students shared their results and finally came to their own conclusions. The last questions of the task did not provide difficulties for the students that always answered them using the software while the teacher circulated through the classroom.

CONCLUSION

This research shows some benefits for statistics teaching in using the software TinkerPlots in the classroom as well as some difficulties regarding students' work, both in using the software and in interpreting statistical concepts and representations. It was observed that students were quite autonomous in handling the software, especially in constructing graphical representations – even in the case of new representations as the boxplot. As in the studies by Lee and Hollebrands (2011) and Rubin and Hammerman (2006), it was possible to confirm that the possibility of finding quickly the sought representations allowed channeling most of class time to the interpretation of results, encouraging students' conceptual understanding. However, after constructing the graphical representation, they revealed uneasiness in interpreting the results and many of them called the teacher to confirm and validate their work or to inquire about how to interpret the representations.

The effectiveness of the software in determining the mean and the median (measures that students already had studied in previous years) allowed the teacher to recall these concepts without substantial use of class time. Using values and examples from everyday life, the teacher managed to effectively recall these concepts. In task 5, the possibility of simultaneous visualization of the dot plot and the boxplot was useful to promote the students' understanding of the concept of distribution, supporting Rubin and Hammerman (2006) as they argue that the software's representations may be used as a basis for group discussions. Given the difficulties shown by some students, the teacher chose to support/guide them focusing their attention on comparing the concentration of points with the boxplot, which proved to be a successful strategy. In task 6, the use of the software enabled a quick simulation of the situation (which otherwise would hardly be done in a timely way). Our study shows that the use of TinkerPlots allowed the teacher to challenge the students to go beyond what is indicated in the curriculum, starting from what they already knew and establishing

connections with their knowledge in a contextualized situation as advocated by Martins and Ponte (2010) and Pratt, Davies and Connor (2011).

The students felt the need to perform calculations, as reported in an episode in task 5. In contrast to their usual routine, in this task there were no computation procedures to carry out and this created a noticeable insecurity in the students. That is, the fact that the software quickly provides the values of the statistical measures led the students to think that they should do something more. They did not seek to interpret the values provided by the software, but simply accepted them almost without questioning. In this situation the teacher decided to conduct a whole class discussion, leading the students to realize the significance of the localization measures, and also to exemplify their calculation. She stressed the need for the interpretation of the concept as a basis to calculate it in a given situation. To promote students' conceptual understanding, the teacher supported and guided the students through focused questions.

The fact that students worked in groups spurred some difficulties that resulted from the interaction within each group and among groups. For example, in task 5 the students compared results with those of neighboring groups, realized that some values were wrong, and requested the teacher assistance. The disparity in results of task 6 observed in different computers also provided some difficulty to interpret what was going on. In this case, the teacher helped the students to overcome this difficulty posing challenging questions that encouraged them to exploit the situation and to relate ideas and concepts. The teacher thus managed a whole class discussion in which she challenged each group to present its results to interpret the situation, as suggested by Connor, Davies, and Holmes (2006). Moreover, as Stein et al. (2008) advocate, the ideas selected for whole class discussion were previously selected in the monitoring phase of work to make the discussion as productive as possible.

By analyzing the teachers' actions in this context, following the model proposed by Ponte, Mata-Pereira and Quaresma, (2013) we observe that in both tasks the teacher chose to interim informing/suggesting, supporting/guiding, and challenging actions. However, in task 5 challenging actions were scarce. The teacher undertook supporting/guiding actions especially when the students requested the validation of the results obtained using the software and that they were not able to read. This happened especially as the teacher felt the need to conduct the students' work to help them to make progress. This action was supported by questions to the students so that they would continue to reason on their own. Informing/suggesting was not much frequent and arose especially in situations where the teacher, monitoring the students' work, was asked to validate arguments already made by students. Challenging actions were found especially in task 6 where the teacher invited the students to explore ideas and to conjecture about the proposed situation, opting to confirm or refute these conjectures in the whole group discussion, with the help of the software. Such questions led the students to understand the concept of simulation by sharing ideas and to make connections between the underlying concepts.

We note that the use of the software had a very significant role. The ease in obtaining representations allowed the teacher to rely on their use as a support to discussions in small groups and in whole class. The use of this tool in the teaching of statistics allowed the teacher to focus attention on concepts rather than on procedures and to manage her actions in bringing the students to work as autonomously as possible.

REFERENCES

- Bishop, A., & Goffree, F. (1986). Classroom organization and dynamics. In B. Christiansen, A. G. Howson & M. Otte (Eds.), *Perspectives on mathematics education* (pp. 309–365). Dordrecht: D. Reidel.
- Boaler, J. (2003). Studying and capturing the complexity of practice: The case of the ‘dance of agency’. In N. Pateman, B. J. Dougherty, & J. T. Zilliox (Eds.), *Proceedings of PME International Conference* (Vol. 1, pp. 3-16). Honolulu, Hawaii.
- Connor, D., Davies, N., & Holmes, P. (2006). Using real data and technology to develop statistical thinking. In G. F. Burrill & P. C. Elliot (Eds.), *Thinking and reasoning with data and chance* (pp. 185-195). Reston, VA: NCTM.
- Franke, M. L., Kazemi, E., & Battey, D. (2007). Understanding teaching and classroom practice in mathematics. In F. Lester (Ed.), *Second handbook of mathematics teaching and learning* (pp. 225-256). Greenwich, CT: Information Age.
- Lee, H. S., & Hollebrands, K. F. (2011). Characterizing and developing teachers' knowledge for teaching statistics with technology. In C. Batanero, G. Burrill & C. Reading (Eds.), *Teaching statistics in school mathematics: Challenges for teaching and teacher education*. New York, NY: Springer.
- Martins, M. E. G., & Ponte, J. P. (2010). *Organização e tratamento de dados*. Lisboa: DGIDC.
- McCrone, S. S. (2005). The development of mathematical discussions: an investigation in a fifth-grade classroom. *Mathematical Thinking and Learning*, 7(2), 111-133.
- Ponte, J. P., Mata-Pereira, J., & Quresma, M. (2013). Ações do professor na condução de discussões matemáticas. *Quadrante*, 22(2), 55-81.
- Pratt, D., Davies, N., & Connor, D. (2011). The role of technology in teaching and learning statistics. In C. Batanero, G. Burrill & C. Reading (Eds.), *Teaching statistics in school mathematics: Challenges for teaching and teacher education* (pp. 97-107). New York, NY: Springer.
- Rubin, A., & Hammerman, J. K. (2006). Understanding data through new software representations. In G. F. Burrill & P. C. Elliot (Eds.), *Thinking and reasoning with data and chance* (pp. 241-256). Reston, VA: NCTM.
- Stein, M. K., Engle, R. A., Smith, M., & Hughes, E. K. (2008). Orchestrating productive mathematical discussions: Five practices for helping teachers move beyond show and tell. *Mathematical Thinking and Learning*, 10, 31.

CORRELATION BETWEEN DIFFERENT LEARNING STYLES AND THE USE OF WIKI IN LEARNING

Nashwa Ismail, Julie-Ann Edwards, Gary Kinchin

University of Southampton

nsei1e09@soton.ac.uk, j.s.edwards@soton.ac.uk, gdk@soton.ac.uk

This paper is investigating the relationship between the learners' Learning Styles (LS): Visual, auditory and kinaesthetic (VAK), and their use of wiki in learning. It highlights the question: How can tutors suit individual learners' preferences according to their LS while using wiki? The benefit of this paper will be for both teachers and students. For students, it may help them to identify their LS in a way that is well-suited when using wiki. This may maximize the benefits that students can gain from using social network in learning. For teachers, this correlation is expected to give them guidance of the students' preferences and abilities with online learning (OL) when using wiki. Therefore, they can select the tool that suits each learner and increases their engagement and communication when using wiki.

INTRODUCTION (CURRENT SITUATION)

According to Richmond and Cummings (2005) since online instructors usually do not engage with students in a face-to-face learning environment, they may be more concerned with the mechanics of course delivery than with the individual concerns of students. Due to the increasingly heavy demand for online distance education courses, there is now an urgent need and responsibility to accurately assess the quality and effectiveness of OL design. Further, there is a need to conduct inquiries regarding the effect of OL delivery on learner outcomes (Moore, 2013). Therefore, it is increasingly important to identify student LS and adapt online course design to accommodate these styles. Social network shows a promising trend in the use of learning. Wiki, specifically, is one of the main applications that has been used in social network. Maddux, Ewing-Taylor, and Johnson (2002) have suggested that considering the relevance of student LS, with regard to design, the instructional methods can ensure the quality of online course design and positive student outcomes. One approach that holds promise for accomplishing this goal is Kolb's (1984) Experiential Learning Theory (ELT), which is illustrated in the following diagram (figure 1).

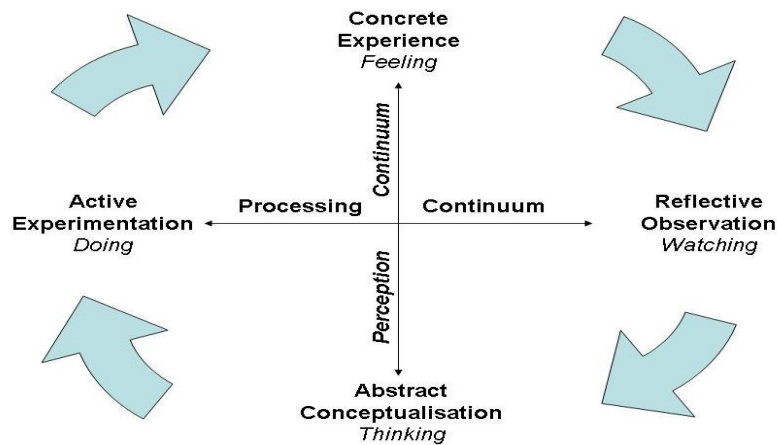

Figure 1. Model of learning styles (Kolb, 1984).

To explain the previous diagram the following bullet points highlight Kolb's terminology in LS:

- Divergent students: look at things from different perspectives.
- Assimilating students: require good clear explanation rather than practical opportunity. These students are looking for a concise and logical approach. Ideas and concepts are more important than working alongside others.
- Converging students: solve problems and use their learning to find solutions to practical issues. They prefer technical tasks more than watching them being done.
- Accommodating students: use other people's analysis, and prefer to take a practical and experiential approach rather than carry out their own analysis.

With regard to figure 1, a student with a dominant LS of 'doing' rather than 'watching' the lesson, and 'feeling' rather than 'thinking' about the experience, will have a LS which combines and represents those processes. Kolb (1984) named these processes 'accommodating'.

In summary, Kolb's LS are the combination of two lines of axis (continuums), each formed between what Kolb called 'dialectically related modes' of 'grasping experience' ('doing' or 'watching'), and 'transforming experience' ('feeling' or 'thinking').

Numerous studies have investigated the impact of LS in learning (Terry, 2001), for educators in public schools (Lemire, 2002), and pre-service student teachers (Raschick, Maypole, & Day, 1998). Recently, Yoshitaka (2010) investigated the impact of LS on the development of learning-skill in higher education, Moreover, Manktelow and Carlson (2013) confirmed that in learning when tutors have information about learner's preference, they can make the most of their learning potential.

Regarding OL, very little research has been focused on the relevance of LS in online courses in higher education (Jurus, Ramos & Castañeda 2008). Another perspective by Shih and Hung (2007) that for the implementation of LS in online learning, learners have to own their dedicated flexible profile. This profile is capable of dynamically

changing as the learners develops and learns. In light of the relationship between LS and the satisfaction of online students, Simpson and Du (2004) found that LS correlated with students' perceptions of class enjoyment. Students with the converging style reported the greatest amount of enjoyment followed by those with diverging, accommodating, and assimilating styles.

From the author's point of view, although the research on LS and distance education is sparse, few findings identified a relationship between LS and course enjoyment (Simpson & Du, 2004). This provided some support for the consideration of LS in online course design. Further, Simpson and Du did not analyse the distribution of LS, to explain the enjoyment of each LS, related to a specific activity that was presented in the course. For example, they did not analyse data that may have highlighted the convergent student's acceptance with watching YouTube videos in OL. Moreover, it could be beneficial to add the academic benefit of this analysis and its reflection on the students' final grade.

In light of the importance of LS, James and Gardner (1995) recommend that teachers assess students and adapt their classroom methods to best fit each student's learning style. Therefore, there are many leaning modalities, each model is based on how students perceive information. Examples of these models such as: Visual, Auditory, and Kinaesthetic (VAK), VARK model Fleming split the Visual dimension (the V in VAK) into two parts - symbolic as Visual (V) and text as Read/write (R). This created a fourth mode, Read/write and brought about the word VARK for a new concept, a learning-preferences approach, a questionnaire and support materials. Moreover, there is the VACT model ("T" breaks out Tactile or touch from Kinaesthetic). For Fleming (2001) both the VARK and the VACT add a fourth mode and category to the mix of the VAK's three style categories. In this paper, VAK model is the model that is used. The reason behind this selection is according to the studied online course via the wiki, students are given activities that are based on the three sensory modes — Visual (seeing and reading), Auditory, and Kinaesthetic (movement and tactile or touch) — to determine three preferred learning-style categories.

Conversely, researchers such as Stahl (2002) and Schank (1995) criticised VAK as learning is a complex and integrated process that could be placed in jeopardy by the practice of LS. Stahl's (1995) criticism was that if students' LS are assessed and matched to instructional methods, then matching has no effect on improving their learning. Moreover, Schank (1995) believed that teachers confused their students' learning by classifying them according to their LS. Schank quite simply thought that LS do not exist. For both of these researchers, the main concern was that if LS were identified, then teacher's instructional method will be specifically directed to these LS. The teacher may then only focus on a student's activity that supports and develops these skills. This may lead to marginalizing other potential skills that can exist within a student. Reid's (1995) one of the proponents who supports the importance of investigating students' LS as they have a direct impact on students' acceptance to learn. Table 1 demonstrates) classification of LS, regarding students' acceptance to learn:

Table 1. Classification of Learning Styles (Reid, 1995).

Used LS (visual, auditory and kinaesthetic)	Facilitating learning and learner's acceptance
Major: related activities are used in this LS	Preferred
Minor: related activities are not highly considered	Learning can still function with little struggle
Negligible: related activities are not used	Can learn, but more difficult

The previous table explains the impact of disregarding students' LS or not knowing it. According to Fleming (2001) this may lead to students' frustration. For example, if students are given activities that are considered to be one of the minor or negligible activities, according to the table students may struggle to learn. Therefore, that leads to their disengagement, frustration or may opt out the whole course.

From the author' point of view, regarding OL, in this environment there is more flexibility and freedom for the learner to view and select all sorts of activities. Nonetheless, identifying these LS for teachers will help them to provide the associated activities and tasks for these LS. For students, knowing their LS could help them to select the activities that suit their abilities and skills. Meanwhile, all other activities are open to be selected and experimented.

In summary, This paper is trying to give an answer that explain how can tutors suit individual learners' preferences according to their LS while using wiki. In details, this paper is trying to associate between the learners' Learning Styles (LS): Visual, auditory and kinaesthetic (VAK), and their use of wiki in learning. Moreover, to find out if these learning styles are positively or negatively correlated with their learning preference.

VAK MODEL

The following section will explain in detail the VAK model of LS, that was created by Fleming (2001) and based on Kolb's (1984) previous model (figure 1). The author has implemented this model as a way to identify the LS of the learners who will be participating in this paper. As according to Sheppard (2013), learners have different strengths, weaknesses, skills and interests. Therefore, they have individual attributes related to their learning and how they perceive the information. In details, some learners rely on visual presentations such as images, these individuals are known as visual learners. Others prefer spoken language and these people are known as auditory learners, while others prefer hands-on activities and are known as kinaesthetic learners.

It is important to know the LS of learners in order to make a correlation between how students learn and how teachers teach (Reid, 1995). Disregarding this information or not knowing it may lead to students' frustration (Fleming, 2001), as learners may be given a certain piece of information while not given the tool that facilitates its understanding. Felder (1995) added that the lack of understanding of students' LS may

impact on learner in two ways; academically, as there may be a reduction in students' acceptance of the subject being studied, and behaviourally, as students' may become aggressive or introverted in class. The author is therefore of the opinion that with OL it is more important to identify learners' LS, in order to engage them with learning. According to Moore (2013) online learners easily get disengaged, demotivated and may opt out the course.

Fleming developed one of the most popular models used to identify learning styles (Fleming, 2001). In this model learners are classified into three main styles. Visual learners, who get information through their visual sense. These learners prefer charts, maps, graphs, data, images and photographs. Auditory learners, who learn best through the hearing sense (Gaven, 2012). These learners are those who are using tones and rhymes in explaining and storytelling. According to Materna (2007), to increase the benefits of learning for auditory learners, they listen first to the information and then they can read it. Therefore, recording lectures and YouTube video are suggested to be appropriate tools for their learning. Finally, kinaesthetic learners, who process information through interacting with the space around them, they make models or role-play in order to physically be involved in learning (Gaven, 2012). Therefore, these learners can be encouraged to learn though creating maps and flashcards to enforce concepts. According to Materna (2007) kinaesthetic learners are more independent learners than learners of other LS, as they adopt self-study strategies that they personally create to help them with learning. From the author's point of view, with regard to Materna's claim (2007), OL in general may suit kinaesthetic learner and enable them to achieve reasonable results, as according to Moore (2013) OL is more independent and student-led environment.

The following section will highlight the use of wiki in learning, as it is the used social network application that the learners have joined to study this course and to identify their LS.

WIKI AS A SOCIAL NETWORK APPLICATION IN LEARNING

Web 2.0 technologies allow website visitors to make contributions and changes to existing web content, and to interact with other members of those websites. They are also designed to facilitate and stimulate collaboration and sharing of information and ideas (Oradini & Saunders, 2008). Therefore, social network is one of the main features in Web 2.0. In this paper, the researcher has selected wiki as a Web 2.0 social network application, to deliver the course in online mode. The evidence of the successful use of wiki has been identified in many areas, such as in the storing of online books. In addition, companies like System Applications and Products (SAP), Motorola, or British Telecommunications utilize wiki as a corporate intranet (Ebersbach, Glaser, Heigl & Warta, 2008). In educational institutions like universities wikis are widely used, for example Blackboard which allows students to collaboratively design and implement websites as part of class content. Blackboard can perform these tasks from separate locations, at any time (Emory University, 2013).

The following section will highlight some basics for the use of wiki. According to Mader (2008a), wiki is a website that allows the easy creation and editing of any number of interlinked web pages, via a web browser. The first wiki was invented by Leuf and Cunningham in the 1990s (Leuf and Cunningham, 2001). Its content is fast and uncomplicated for end users as it is based on capturing and sharing content between all users. In addition, for teachers it is successful in monitoring complex tasks, tracking memos, creating plans and providing a powerful resource of knowledge. Wiki also extends page length, as most have no page limit, unlike other mail servers which have restrictions on the number of web pages. Lindsay (2009) explained more extended features of wiki, such as: the ability to embed multimedia into a wiki, e.g. videos, Really Simple Syndication (RSS), images, etc. History tab to show all edits on the page. Ebersbach et al. (2008). Versioning system: to save the history of each page and re-establishing previous changes if needed (Mader, 2008b). Change alerts: this allows wiki administrators to be notified, monitor and track any changes on any page (Chatfield, 2009).

In general, educators can harness wiki in diverse applications, such as implying course content, organizing schedules, attaching related files and following up students' "brainstorms". This helps to identify any possible obstacles in the students' learning as early as possible, alleviate actual assessment and facilitate the collaborative brainstorming of ideas. These features provide wiki with the flexibility to be applied in many fields and different activities.

From the author's point of view, wiki provides a collaboration of knowledge, where each user can take part in creating and sharing information. This concept is in line with Vygotsky's notion (1978) where each person can learn if they join knowledge communities. All of the aforementioned features mean that wiki is to be highly recommended for closed communities, such as schools and colleges.

METHODOLOGY

This is a quantitative study, 30 students at a learning academy enrolled in a 6 month vocational IT course. This course qualifies them with National Vocational Qualification (NVQ) certificate. Students were studying in a blended mode, where they were attending the class once a week, while the rest of the study was dependent upon OL. Students were communicating and collaborating with each other and their teacher via wiki as a social space. This private wiki was created for this class only. This wiki is provided with different learning tools range between audio and video recording, games and readable text files. Each tool is created to support different learning styles. These tools, expressed in the graphs as students' preferences, were selected based on LeFever (2011) LS classification that matches the instructional style to the individual learning. To collect empirical data, a semi-structured questionnaire was distributed to all participants. The types of questions used in the questionnaires vary between rating scales (from 1-10), intensity-scaled questions (including categories such as 'excellent', 'very good', 'good', 'fair', and 'poor'), as well as a few open-ended questions to enable

the respondents to write free responses in their own terms. According to Cohen et al. (2007) open-ended questions help gathering a combination of qualitative and quantitative data. The semi-structured questionnaire was designed to address the following questions:

Main research question: How can tutors suit individual learners' preferences according to their LS while using wiki? and subordinate research question: What are the students' preference in online learning media such as: audio, video, text or games and simulations?

Beside the questionnaire, students had two assessments:

- Students' LS assessment at the beginning of the course. Participants completed an LS assessment to describe their learning preference. It's worth mentioning that, there are many VAK tests to assess learners' preferences. The author has used this specific test as it is designed by (Neuro Linguistic Programming) NLP experts, who rely on the sensory representation preference to assess the VAK style of learners (Ellerton, 2010).
- Students' final course assessment to evaluate their knowledge about the course content. The reason for using these grades that they help the researcher to provide feedback on the students' learning and to give an indicator that the used tool(s)(audio-video-text...) for each individual fulfil his/her preferences and helps to achieve their academic success.

In summary, the researcher followed the following approach in collecting data:



Figure 2. Research approach.

DATA

(1)What does the visual, auditory and kinaesthetic learner request while learning online?

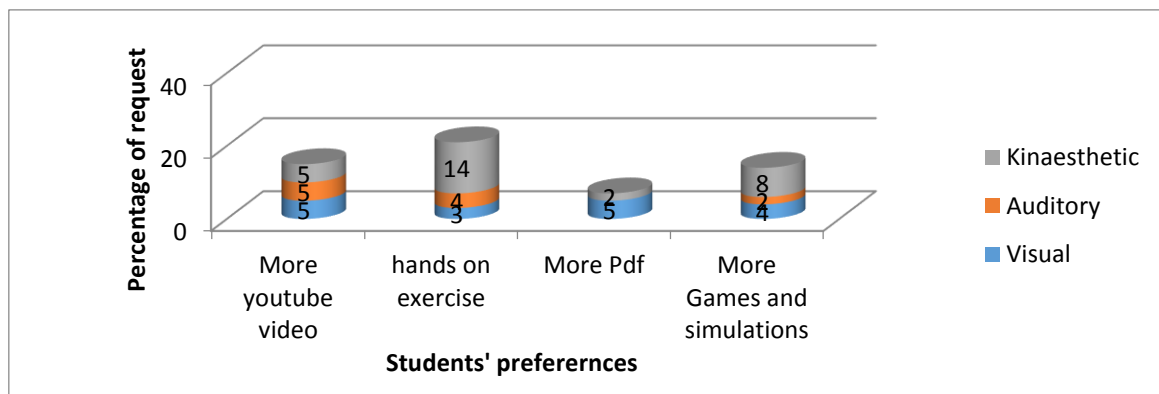

Figure 3. Correlation between LS and students' preferences in OL.

Figure 3 shows statistical significance with the request of YouTube videos from learners in all LS. Hands on exercises are an important need for kinaesthetic learners, while reading files such as PDFs are more requested by visual learners.

(2) How does each learner perceive wiki as an online social learning application?

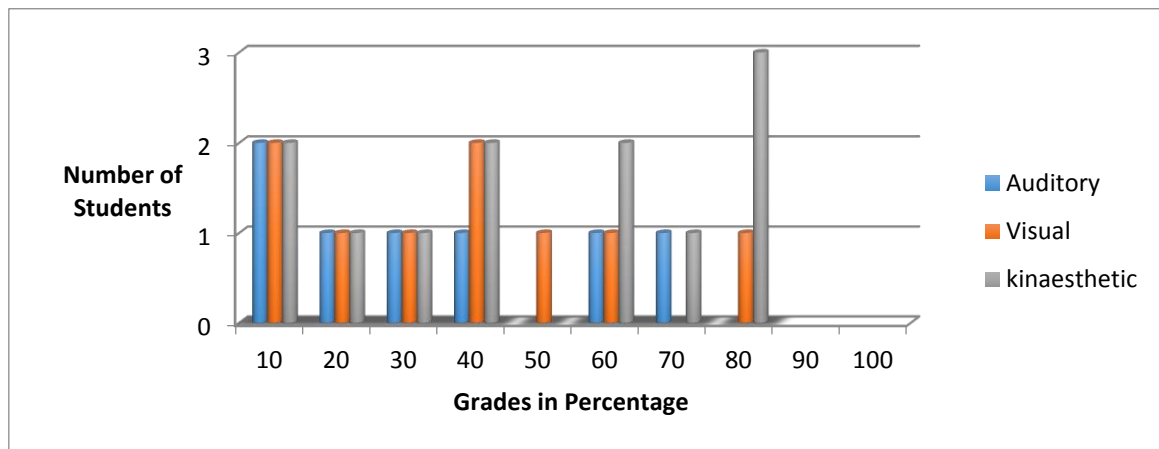

Figure 4. Correlation between LS and the percentage that social network helped students to study their course.

Figure 4 shows statistical significance that the use of wiki helped students in studying with the following ratios: kinaesthetic learners (average 70%), visual learners (average 25%) and auditory learners (average 20%).

(3) What is the final academic grade for each learner after studying the course online?

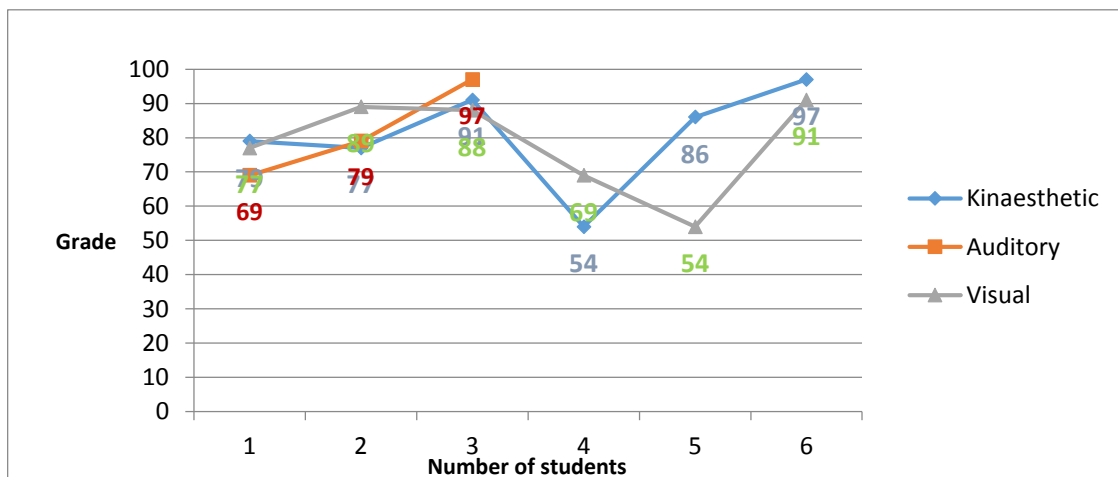

Figure 5. The correlation between LS and the student's final exam grade in percentage.

Figure 5 shows statistical significance that kinaesthetic learners achieving the highest grade compared to other LS. Visual learners have achieved average score, while auditory learners did not follow a clear pattern in their scores. This is possibly because

the recruitment of auditory learners was low, therefore the data did not indicate significance or correlation.

RESULTS AND FINDINGS

Regarding the correlation between LS and students' preferences in OL, there was a balanced learning preference between all LS regarding the use of YouTube videos in wiki. Statistical significance was found for the preference of kinaesthetic learners to use hands on exercises. Similarly, a significant preference for the reading files such as Text and PDF files for visual learners.

With reference to the correlation between LS of learners and the percentage that social network assisted them to study this course, wiki achieved a significant contribution for kinaesthetic learners in their learning. Wiki also achieved a balanced contribution for visual and auditory learners in their learning.

With respect to the correlation between LS and the student's final exam grade, there was a significant academic achievement for kinaesthetic learners. A moderate academic achievement for kinaesthetic learners was identified, while no significant differences were observed for auditory learners. This is agreed with Manktelow and Carlson (2013) who positively correlated between identifying the learners' preference and maximizing their learning potential.

In summary, it can be claimed that, tutors' knowledge and consideration of student's LS, can help them to guide their learners in selecting the learning tools that can suit their learning preferences. For example, based on the findings in this paper, by identifying that a certain learner is mainly kinaesthetic, tutor can guide that learner by providing more tutorial YouTube, simulations and hands on experience. Moreover, tutor can encourage this learner to join and collaborate with other learners in online social forums. This result can be generalized to other learning styles for other learners.

RECOMMENDATIONS AND CONCLUSION

It is important for any online course that both teachers and students identify the LS of learners. Therefore, uploading a VAK test in the OL course is one of the recommendations in this study. Castaneda et al. (2008) confirmed that LS may be easily studied amongst distance learners, and has the potential to reveal preferences that educators should consider in their teaching activities.

Table 3, which is stemmed out from the literature, where their basic preferences for each LS are explained, illustrates the paper findings learners' for each LS regarding their OL preferences:

Table 2. Summary of students' preferences in each learning style.

Learner style	OL preferences
Auditory	- Listening to podcasts, and audio and video downloads related to the studied topic.
Visual	- Online links to videos that access the course content. - Online text or other visual aids in interactive games and simulations
Kinaesthetic	- Mobile learning, exploring the web or completing research projects. - Participating in outdoor <i>activities</i> , to complete assignments and then report their findings and reactions to their peers in a forum.

Further two recommendations, the first that confirms the claim of Shih and Hung (2007) about the importance of flexibility in OL. From the authors' point of view, online course design itself can encompass flexible authoring facilities. So, with the tutors guidance and support, learners can make the changes of the course design that can suit their learning preference. Consequently, I recommend the use of other Web 2 strategies that may provide opportunities for increased interaction and flexibility in online learning. Examples of these strategies such as: live chat rooms, threaded discussions, and the use of blogs simultaneously with wiki, combined with prompt responses to all email inquiries and real-time Frequently Asked Questions (FAQs).

The second recommendation may help to minimise the drawback that may exist when tutors classify students according to their LS. As according to Stahl (2002) and Schank (1995) sometimes, teacher's instructional method will be specifically directed to these LS. Therefore, I recommend that after identifying each learners' LS, teachers can start to develop a multisensory learning environment, rather than tailoring teaching techniques to each individual. This combination of simultaneous congruent stimuli will enable an entire classroom to improve their encoding, storing and retrieval of information.

Finally, this paper could investigate the LS of wiki students and draw guidelines to motivate and engage these learners. It may give evidence through identifying LS of OL, as clear correlations were drawn between these learners, their academic performance and their learning preference. Moreover, it can be said that each learner has his/her own abilities and perceptions to receive information. Therefore, knowing and understanding their LS may help wiki tutors to design and implement wikis to suit these learners.

REFERENCES

- Chatfield, T. B. (2009). *The complete guide to wikis: how to set up, use, and benefit from wikis for teachers, business professional, families and friends*. Ocala, Florida: Atlantic Publishing Group.
- Cohen, L., Manion, L., & Morrison, K. (2007) *Research methods in education*. 6th edition. Routledge: London.

- Ebersbach, A., Glaser, M., Heigl., R. &Warta, A. (2008). *Wiki: Web Collaboration* (2nd ed.). Berlin: Springer.
- Ellerton, J. (2010). *Live your dreams. Let reality catch up: nlp and common sense for coaches, managers and you*. Oxford: Trafford Publishing.
- Emory University. (2013). *Welcome to the Discussions Resources Wiki!*. Retrieved from <http://emorydisc.wikispaces.com/>.
- Felder, M. R. (1995). Learning and Teaching Styles in Foreign and Second Language Education. *Foreign Language Annals*, 28(1), 21- 31.
- Fleming, N. D. (2001). Teaching and Learning Styles: VARK Strategies. *Honolulu Community College*. Retrieved from <http://www.how-tostudy.com/LearningStyles.htm>.
- Gavan, A. (2012). *Visual, auditory and kinaesthetic (vak) learning style*. Retrieved from <http://www.jcu.edu.au/wiledpack/modules/fsl/JCU090460.html>.
- Hinchliffe, D. (2006). *Blogs, wikis, and web 2.0 as the next application platform*. Retrieved from <http://www.zdnet.com/blog/hinchcliffe/blogs-wikis-and-web-20-as-the-next-application-platform/50>.
- James, D., & Gardner, D. (1995). Learning styles: implications for distance learning. *New Directions for Adult and Continuing Education*, 67.
- Juris, M. F., Ramos, V., & Castañeda, M. G. G. (2009). Learning and teaching crossroads. *Institute for Learning Styles Journal*, Spring, 1, 1-19.
- Kolb, D. (1984). *Experiential learning as a science of learning and development*. Engelwood Cliffs, New Jersey: Prentice Hall.
- LeFever, M. (2011). *Learning styles*. Colorado: David C. Cook
- Lemire, D. (2002). Brief report: What developmental educators should know about learning styles and cognitive styles? *Journal of College Reading and Learning*, 32(2), 177-182.
- Leuf, L., & Cunningham, W. (2001). *The wiki way: quick collaboration on the web*, Addison-Wesely: Boston.
- Lindsay, J. (2009). *Web 2.0 and learning*. Retrieved from <http://julielindsay.wikispaces.com/Web2+and+Learning>.
- Mader, S. (2008a). *What is a wiki and how does it work/?* Retrieved from <http://kibesa.wikispaces.com/Definition+of+a+wiki>.
- Mader, S. (2008b). *How do you use a wiki? Poll results*. Retrieved from http://blogs.atlassian.com/news/2008/03/how_do_you_use.html.
- Maddux, C. D., Ewing-Taylor, J., & Johnson, D.L. (Eds.). (2002). *Distance education: Issues and concerns*. New York: The Haworth Press

- Manktelow, J., & Carlson, A. (2013). *Understanding your learning preference*. Retrieved from <http://www.mindtools.com/mnemlsty.html>.
- Materna, L. E. (2007). *Jump-start the adult learner: How to engage and motivate adults using brain-compatible strategies*. CA: Corwin Press Incorporated.
- Moore, M. G. (2013). *Handbook of Distance Education*. NY: Routledge.
- Oradini, F., & Saunders, G. (2008). The use of social networking by students and staff in higher education. In *Proceedings of the iLearning Forum 2008 Conference and plugfest*. (pp. 236-242). Champlost, France: European Institute for E-Learning. Retrieved from http://www.l-eife/proceedings/ilf08/contributions/improving-quality-of-learning-with-technologies/Oradini_Saunders.pdf.
- Raschick, M., Maypole, D. E., & Day, P. A. (1998). Improving field education through Kolb's learning theory. *Journal of Social Work Education*, 34(1), 31-42.
- Reid, J. M (1995). *Learning styles in the esl/efl classroom*. Boston: Heinle & Heinle.
- Richmond, A. S., & Cummings, R. (2005). Implementing Kolb's learning styles into online distance education. *International Journal of Technology in Teaching and Learning*, 1(1), 45-54.
- Schank, R. C. (1995). *What we learn when we learn by doing*. (Technical Report No. 60). Northwestern University, Institute for Learning Sciences.
- Sheppard, A. L. (2013). Learning styles and motives of postgraduate distance learners undertaking a United Kingdom professional doctorate. *Journal of Perspectives in Applied Academic Practice*, 1(1). DOI:10.14297/jpaap.v1i1.40.
- Shih, T. K., & Hung, J. C. (2007) *Future directions in distance learning and communications technologies*. USA: Idea Group Publishing.
- Simpson, C., & Du, Y. (2004). Effects of learning styles and class participation on students' enjoyment level in distributed learning environments. *Journal of Education for Library and Information Science*, 45(2), 123-136.
- Stahl, S. A. (2002). Different strokes for different folks? In L. Abbeduto (Ed.), *Taking sides: Clashing on controversial issues in educational psychology* (pp. 98-107). Guilford, CT, USA: McGraw-Hill.
- Terry, M. (2001). Translating learning style theory into university teaching practices: An article based on Kolb's experiential learning model. *Journal of College Reading and Learning*, 32(1), 68-85.
- Vygotsky, L. S. (1978). *Mind in society*. London: Harvard University Press.
- Yoshitaka, Y. (2010) Impact of learning styles on learning-skill development in higher education. *International University of Japan, Graduate School of International Management*. Retrieved from <http://www.ua.ac.be/main.aspx?c=.ELSIN&n=95888>.

THE ROLE OF PEER AND COMPUTER FEEDBACK IN STUDENT'S PROBLEM SOLVING

Júlio Paiva*, Nélia Amado**, Susana Carreira**

*Agrupamento Vertical Dr. Francisco Fernandes Lopes, Olhão

** FCT, University of Algarve and Research Unit of the Institute of Education of the University of Lisbon, Portugal

juliopaiva@aeffl.pt, namado@ualg.pt, scarrei@ualg.pt

In this paper we present an episode of a teaching experiment with a class of 8th graders where since the previous year (7th grade) the computer was integrated in the learning of geometry. The learning context is characterized by the importance given to student-student interactions. The overall aim of the research is to understand the role of the emerging peer feedback and computer feedback in student's problem solving with the use of technology. We adopted a qualitative and interpretive research methodology. The data presented are based on an episode involving the actions of a pair of students while solving a geometry problem. The application of a model of feedback phases to the empirical data and its subsequent interpretation led to a set of evidences about the role of feedback (peer feedback and computer feedback) in problem solving with technology.

INTRODUCTION

Research has provided solid arguments for the integration of computers in mathematics teaching and learning. In particular, the use of technology may facilitate interaction and communication between students when they get involved in the construction of mathematical meanings (Arzarello & Robutti, 2010).

In the past, geometry was often presented to students as a finished product, like a fixed system of axioms, definitions, theorems, postulates, constructions, and statements, created for unknown reasons and by unknown people and ready to be inertly assimilated by students. More recently it is intended that students “do geometry”, that is, students are expected to actively engage in open-ended tasks that involve problem solving and allow them to define mathematical objects and discover their properties. The computer provides several features that enable the learning of most topics of geometry and support problem solving in geometry. In technological environments students are more impelled to reflect on the mathematical implications of their actions as it opens up the possibility of easily and rapidly trying out new ideas in ways which are impossible with paper and pencil.

Given that effective problem solvers monitor their own mental processes as they plan, implement and reflect on a learning task, learners need to be given opportunities to discuss what goes on in their minds. This means that many opportunities to practice,

reflect, challenge and revise have to be available (Earl & Katz, 2008).

Furthermore, the use of technological environments associated with proposing exploratory or investigative tasks is a significant curricular trend (Ponte et al., 2007).

ON THE CONCEPT OF FEEDBACK

The notion of feedback has evolved over time. Although the understanding of feedback is not exclusively dealt with in assessment, as Sadler (2010) points out, much of the empirical studies on feedback are from that field (Natriello, 1987; Crooks, 1988; Black & Wiliam, 1998; Hattie & Timperley, 2007). Initially reduced to sanctioning student's errors (fig.1A), later it started to incorporate information from students' actions as a way to feed back the process of teaching and learning (fig.1B).

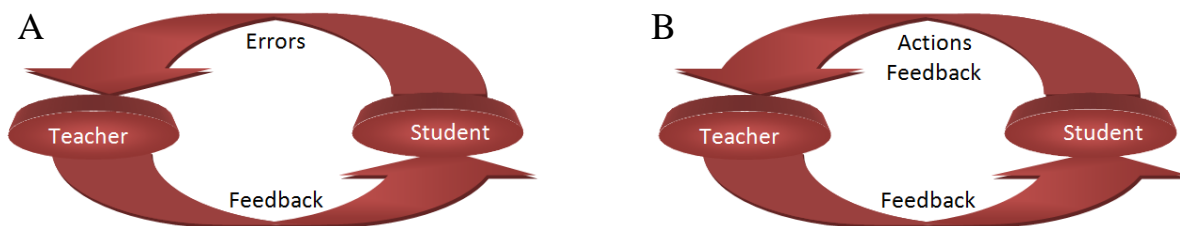

Figure 1. Models of feedback.

Under the conception of feedback reported in figure 1A, much of the feedback provided by the teacher has no impact on student learning (Taras, 2013). As noted by Black, Harrison, Lee, Marshal, and Wiliam (2003, p. 58) “teachers... found it extremely difficult, if not impossible, to offer advice to the students as to how to improve”.

In this article we propose a conception of feedback as a dialogical and relational process. Here feedback takes the form of a dialogue opened to all participants. In this context, the role of the teacher is to stir dialogue with and among their students (co-constructive dialogues between pairs) and the role of the learner is to be actively involved in the process (Askew & Lodge, 2000).

Black and Wiliam (2010) refer that we have now a clearer idea on the importance of the interactive dialogue between teacher and students and among students themselves, and placed it at the core of formative assessment practices.

Feedback may therefore be seen as dialogue (Askew & Lodge, 2000), as “an interaction between parties with the intention of generating a shared understanding” (Price at al., 2013, p. 43).

Situations that lead students to support others and to receive help from peers are rich experiences in restructuring their own knowledge, in regulating their learning, and in promoting responsibility and autonomy (Santos, 2002).

In this context, it makes sense to refer to co-regulation as a continuous unfolding of individual actions, capable of being continuously modified by the actions of the peers (Fogel, 1993).

Many students prefer to learn with their peers than with teachers, reacting differently in each case (Prensky, 2010). Empirical evidence tells us that, under the right conditions, students working with their peers receive more feedback and support, with better quality than they would get only from the teacher. What underlies this quality is that students continue to question each other when they do not understand (unlike the interactions with the teacher that end up ceasing), and also because students use a more accessible and understandable language (Smith, 2007).

In mathematics classes, students' dialogues within their groups are forms of engaging them in describing, predicting, explaining and exploring, thus helping to build understanding (Britten, Stevens & Treby, 2012). The dialogues between students, when working with a computer, are naturally driven by the images shown on the screen (computer feedback) and grow from students need to justify and clarify their own conjectures (Yu, Presmeg & Barret, 2009).

In a context of learning that involves the interaction between students and between the students and the computer, we developed a teaching experiment with the implementation of various tasks as the basis to explore the role and relevance of feedback. Throughout the activities performed with the computer, using Geogebra, we could detect chains of feedback between students and between the computer and the students, which contributed to the problem solving process.

METHODOLOGY

In this study, the teacher (first author) assumes the dual role of teacher and researcher. The research follows a qualitative and interpretative methodological approach and is centred on a teaching experiment of using Geogebra in the classroom. The class consisted of 22 students aged between 12 and 14 years.

In this experiment the computer was gradually introduced along 33 tasks through four subtopics of geometry in a two-year teaching program, allowing students to adapt to the technology and become Geogebra natural users. Students worked in pairs, with a computer for each pair.

In this article, we will give particular emphasis to the work of two students, who were given the names of Andre and Lukas, so as to preserve anonymity.

Data collection involved participant observation, audio and video recording of lessons, and students' productions. We used audio recordings of conversations between peers, video recordings of students' actions in the computer and we collected the Geogebra files produced by the students.

In this paper, we describe and analyse one episode related to a problem solving task. For data analysis, a descriptive model of feedback phases adapted from Kollar & Fischer (2010) was used (figure 2). The model comprises the phases of:

Performance – A student interacts with the computer performing an action in a given task. This action may result from a strategy established with a partner or not.

Feedback Provision – Following the student’s action, visual feedback provided by the computer appears, which may be complemented by possible oral feedback from a peer. This peer feedback focuses on the thinking process; it may reveal doubts, discordance or approvals, indications or simple findings resulting from actions, procedures or reasoning.

Feedback Reception – The reception of feedback by a student may lead to the emergence of a response (generating feedback to feedback) and thus leading to a cyclical process, termed as interactive dialogue, whose aim is to clarify actions, procedures or reasoning, which can be used as a lever to the process of co-regulation.

Construction Process Revision – A new search for strategies starts, opened to the participation of each student in order to enhance a new action. This step consists of proactive (feed forward) and reactive strategies. Reactive strategies are those in which a student responds to visual feedback while manipulating geometric figures. Proactive strategies are those in which the student determines which actions to take before carrying them out, feeding forward the process. While in the reactive strategies the student is more dependent on the feedback provided by the computer, in the proactive strategies the student starts from mathematical properties and uses the computer to implement a specific plan (Hollebrands, 2007).

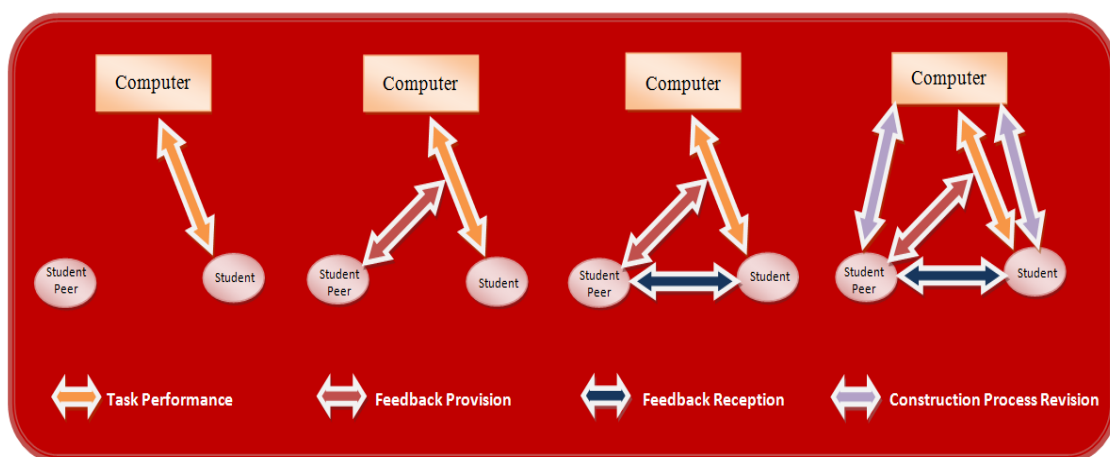

Figure 2. Model of feedback phases.

THE ANALYSIS OF AN EPISODE

When the episode took place, students were used to explore the affordances of Geogebra. This episode focuses specially on a pair of students (Andre and Lukas). The task (adapted from Trigo (2004)) comprises a set of instructions for building a figure similar to the given below (figure 3).

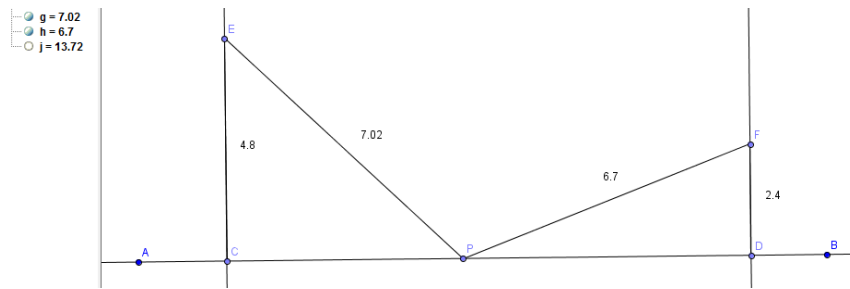

Figure 3. Given figure for the problem of wire connecting poles.

The vertical line segments represent electricity poles connected by an electric wire that must be attached to the floor somewhere between them. The goal is to know where to locate the point between the poles in order to spend as less wire as possible.

At first, Andre takes control of the computer and later the students are taking turns. The direct interaction with the computer had been an object of negotiation between the two students. Andre begins drawing a horizontal line through two points and he quickly decides to show the grid that, in his view, would become helpful. Then he starts by drawing additional lines as shown in figure 4.

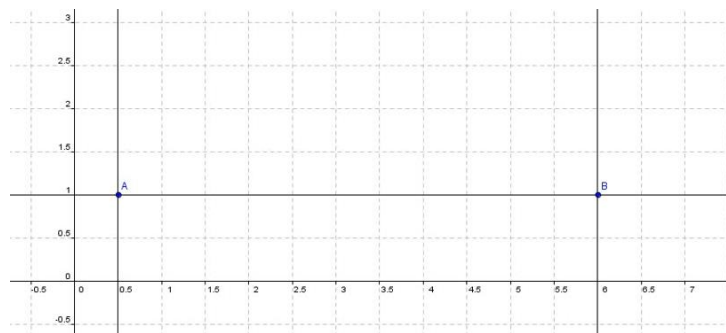

Figure 4. Initial construction.

Then he sets the points that define the ends of each pole and constructs the segments that represent the poles. He measures the two segments whose lengths are 2 units and 1 unit, respectively. After that, he defines the midpoint of the horizontal segment between the bases of the two poles. Finally, he constructs the segments representing the two pieces of wire by joining the highest point of each pole to the midpoint of the horizontal segment. The students change roles and Lukas takes over the computer. Lukas renames the points and reflects the rectangle triangle having the higher pole as one of the sides, in following Andre's suggestions (figure 5). He also constructs the segment that joins the end of the reflected higher pole to the end of the lower pole, which crosses the horizontal line.

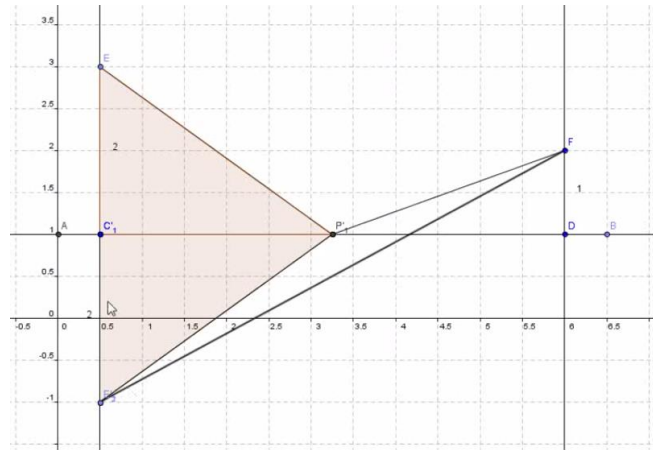

Figure 5. Construction with the reflected triangle.

Then Lukas wants to drag the point where the two pieces of wire are joined but the point does not move as Andre had defined it as the midpoint of the horizontal segment and therefore as fixed point. Lukas hides the point where the two pieces of wire join (the midpoint of the horizontal segment), after getting Andre's agreement, and he looks for the tool that allows finding the intersection point between two lines.

At that point, the teacher calls the attention of the class to the need for using measurements to investigate the best location for the point where the two pieces of wire join.

Looking closely at the image on the screen, Lukas considers the lengths of the poles:

Lukas: Look this one is higher; is it true that the distance from this one to the point of intersection is greater?

Shortly after, Lukas decides to erase all the constructions and starts over. He suggests that Andre then takes over the computer and remakes the construction until the point where it would be necessary to move the point where the two pieces of wire join.

Andre repeats the same procedures for the construction of the poles and finally defines the point P as a free point on the horizontal line. After drawing the segments EP and FP (from the top of the poles to the point P on the floor), Andre measures their lengths. The heights of the poles are again 2 units and 1 unit.

Lukas: Now, if this one has two units of height and this one has only one unit of height, which of the two will need more wire from top to bottom?

Andre: Need?

Lukas: Here, if you think of height, this one will need twice the length of the other. What matters more? The height or the base?

Andre: What is said here [in the problem]? Spend as little as possible?

Lukas: Yes.

Andre: As little as possible means that we should make the two [wires] equal.

Andre makes the experience of dragging the point P, and observes the outcome. When he drags the intersection point the following dialogue arises:

Andre: Do the sum: $3.12 + 3.26$.

Lukas: Oh yeah. I know how we'll do it. (He uses the calculator).

Andre: It's 6.38. And now if we change this to 3.2 (referring to one of the pieces of wire), it gives 6.36 (sum of the lengths).

Lukas: Yes. Which way did you drag it?

Andre: This way.

Lukas: That way? Then you're wrong, you have to drag it to the other side.

Andre: Yes (he drags again). With 3.1 (referring to one of the pieces of wire) it gives 6.39 (sum of the lengths).

Lukas: The answer will be 6.36 then.

Andre: Yes, it's this way.

Lukas: Wait, don't move it. Look, this is not the right answer.

Andre: Ah, now it's here. (He drags the point again).

Then Andre measures the angles and notices that the angles between the wires and the horizontal line have very close amplitudes.

Andre: No it's not. It's here: twenty eight, twenty eight. (Referring to the angles sizes).

By carrying out the dragging and the observation of the angles sizes (figure 6), the students realized that the solution corresponded to the point where the two angles would have equal sizes.

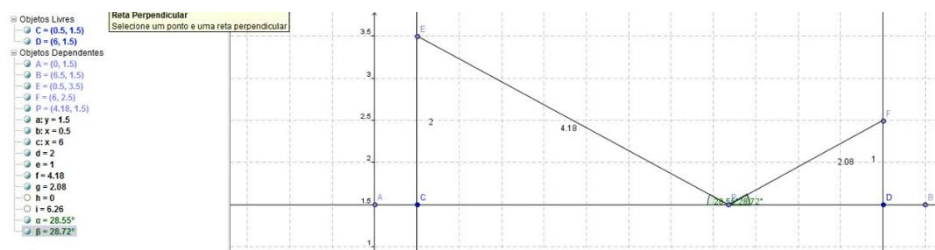

Figure 6. Final construction with the angles.

According to the peer feedback model involving technology that was proposed above, we can identify a sequence of phases where performance, feedback and revision were important for a deeper understanding of the problem and its solution. In table 1, we present a summary of the feedback cycles taking place in connection with the key points of students' problem solving activity with Geogebra.

Table 1. Description of the phases of feedback.

Feedback Phases	Key points from the episode
<i>Performance</i>	Lukas tries to drag the point on the horizontal line where the two segments join.
<i>Feedback Emergence</i>	The computer doesn't allow the movement of the point.
<i>Revision</i>	Lukas suggests that the position of the point depends on the heights of the poles.
<i>Performance</i>	Andre remakes the construction of the figure.
<i>Feedback Emergence</i>	Lukas questions Andre about which of the poles will need more wire and about what matters more to the wire length: the height or the basis of the triangle.
<i>Feedback Reception</i>	Andre revisits the aim of the problem and proposes making the lengths of the wires equal.
<i>Performance</i>	Andre makes the experience by dragging the point on the horizontal line.
<i>Feedback Emergence</i>	The computer shows the change of the lengths as the joining point changes.
<i>Performance</i>	Lukas computes the sum of the two lengths as Andre asked him.
<i>Feedback Emergence</i>	When the result of the sum increases Lukas suggests that Andre changes the direction of dragging.
<i>Performance</i>	Andre changes the direction of dragging.
<i>Feedback Emergence</i>	The computer shows the change of the lengths.
<i>Performance</i>	Lukas computes the sums and concludes that the answer is 6.36 units.
<i>Feedback Emergence</i>	Andre says they are moving in the right way.
<i>Performance</i>	Andre keeps dragging and trying.
<i>Feedback Emergence</i>	Lukas asks him to wait; he seems to doubt that the right answer was actually found.
<i>Performance</i>	Andre keeps dragging the point.
<i>Feedback Emergence</i>	Lukas says that it's not the right answer.
<i>Feedback Reception</i>	Andre disagrees.
<i>Revision</i>	Andre decides to measure the angles.
<i>Performance</i>	Andre measures the angles.
<i>Feedback Emergence</i>	The computer shows two equal sized angles.
<i>Revision</i>	The students conclude that the solution to the problem is found when the two angles are equal.

CONCLUDING REMARKS

In this episode, continuous and interactive feedback fuelled by the use of the dynamic geometry environment gave rise to the so-called co-constructive dialogue between students, where knowledge is jointly constructed through dialogue (Askew & Lodge, 2000). In order to explore the full potential of dialogue in mathematics learning it is crucial to create an environment where dialogue is unceasing (Britten, Stevens & Treby, 2012).

Feedback is an integral part of the ongoing dialogue. The episode clearly reveals how co-regulation was a product of peer feedback and visual feedback from the computer. The mutual feedback appears integrated in the learning, suggesting a series of loops in the development of the problem solving activity (Askew & Lodge, 2000). The structure consistently reiterated, as depicted in figure 7, emerges as a strong feature of the activity.

We may notice that some of the loops emerge with blanks. This means that some phases do not appear in verbal format or in the form of actions, but they are taking place within the triad composed of the peers and the computer. Other phases are only implicitly present through actions such as, for example, when students adopt new strategies to solve the problem without spelling them out orally. An example is given by the construction of the line segment joining the reflected top of the higher pole and the top of the lower pole (crossing the horizontal line). This particular construction seemed to influence Lukas thinking on the need to change the position of the point on the horizontal (initially defined as the midpoint of the base). In general, the successive

cycles of feedback phases indicates an obvious occurrence of students' exploratory work, some of which are sometimes not continued as they are overtaken by other ideas and approaches to the problem.

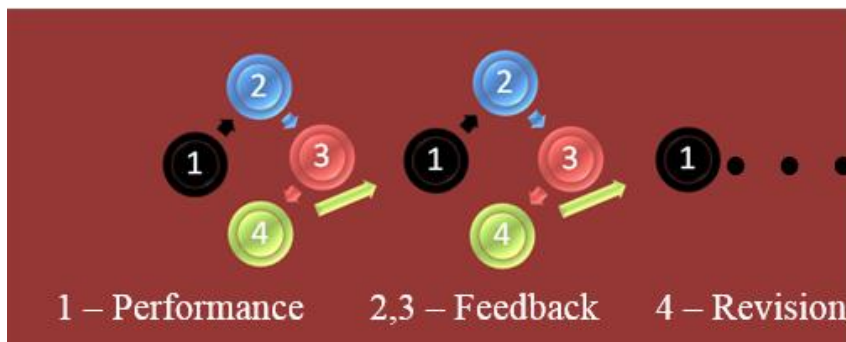

Figure 7. The loops of development in problem solving.

The episode clearly reveals that co-regulation emerges as feedback between students and visual feedback from the computer arises, in the sense that there is a continuous unfolding of actions that are likely to be constantly modified based on permanent feedback coming from students and from the computer.

The visual feedback from the computer became relevant in several moments. The first idea held by Andre was based on the perception that the two pieces of wire would connect at the midpoint of the horizontal line. This has probably guided the construction he made with Geogebra. However, as Lukas tried to drag the connection point (which he was expecting to be a movable point along the horizontal line), the immediate feedback from the computer showed that the construction was static and would not serve the purposes of exploring different positions for the two pieces of wire. As soon as the figure was reconstructed and the connection point was able to move on the horizontal line, the dragging action and the measurements displayed provided immediate feedback on the lengths of the two wires. The concept of *feedback on feedback* emerges in the phase of feedback reception when, for example, Lukas tries to relate the heights of the poles with the lengths of the two wires and Andre offers a conjecture, which consists of making the two wires of equal lengths.

Although the dialogues are characterized by spontaneity, informality and openness, the meanings that students are developing for the problem situation seem to be built at each step. This is visible in the way students consistently reshape the intentionality of their actions. On the one hand, Lukas tries to understand how to model the horizontal distances between each pole and the point on the floor; on the other hand, Andre seems to look for some kind of condition which will substantiate the solution to the problem: first, he thinks about the connection point equally distant from the two poles; then he goes on to consider equal lengths for the two pieces of wire. An example of the dissenting views can be seen in the last part of the episode when Lukas disagrees of Andre's assumption about having found the optimal solution; Lukas seems to believe that the position found by his peer is not the right one; however it is important to note that Andre's point of view ultimately had an effect on getting the solution, since he

eventually proposed a condition that leads to the solution of the problem: the two angles between the wires and the horizontal must be equal. This idea also seems to agree with Lukas' perspective of considering the position of the connection point as somehow related to the heights of the poles. At that point, both views on the problem became compatible.

We want to note the emergence of reactive strategies, like when Andre drags the intersection point and sees the sum of the lengths increasing and Lukas reacts by saying that the point has to be moved in the opposite direction. As well, we note the appearance of proactive strategies, like when Andre decides to measure the size of the angles and explore that new aspect of the figure. The notion of proactive feedback or feed forward can be seen here as a set of information that leads the students to act in order to achieve a certain goal, either immediately or later on.

The search for peer feedback is also quite evident in students' dialogue as in the case where Lukas questioned Andre about which of the poles will need more wire and what mattered more in the change of the lengths of the wires – the height or the base of the triangles. This prompted Andre's conjecture on considering the two pieces of wire with equal lengths and led to further experimentation and verification. According to Keeley and Tobey (2011), it is important to emphasize students seeking feedback from other students as opportunities for them to assess their thinking and reasoning (Donovan & Bransford, 2005).

In short, the computer represented an important source of feedback that was coupled with peer feedback in the construction of meaning for the solution to the problem. In this episode, we observed that, starting from two distinct visions to interpret the required position to minimize the wire length, the actions and reactions were leading to a conclusion that found echo in both students' perspectives. Although not having justified the reason for the two equal angles, the two students were confident of having found the right solution.

REFERENCES

- Arzarello, F., & Robutti, O. (2010). Multimodality in multi-representational environments. *ZDM*, 42, 715–731.
- Askew, S., & Lodge, C. (2000). Gifts, ping-pong and loops - linking feedback and learning. In S. Askew (ed.) *Feedback for learning*, (pp. 1-18). London: Routledge Falmer.
- Black, P., Harrison, C., Lee, C., Marshal, B., & Wiliam, D. (2003). *Assessment for learning: putting in to practice*. Maidenhead: Open University Press.
- Black, P., & Wiliam, D. (1998). *Inside the black box: raising standards through classroom assessment*. London: School of Education, King's College.
- Black, P., & Wiliam, D. (2010). A pleasant surprise. *Phi Delta Kappan*, 92(1), 47-48.

- Briten, E., Stevens, S., & Treby, N. (2012). Using talk for learning in science and mathematics. In D. Jones e P. Hodson (eds.) *Unlocking Speaking and Listening*, 2nd Edition, (pp. 19-34). London e New York: Routledge.
- Crooks, T. J. (1988). The impact of classroom evaluation practices on students. *Review of Educational Research*, 58, 438-481.
- Donovan, S., & Bransford, J. (2005). *How students learn mathematics in the classroom*. Washington, DC: National Academy Press.
- Earl, L., & Katz, S. (2008). Getting to the core of learning – Using assessment for self-monitoring and self-regulation. In S. Swaffield (Ed.) *Unlocking Assessment – Understanding for reflection and application*, (pp. 90-104). London: Routledge.
- Fogel, A. (1993). *Developing through relationships: Origins of communication, self, and culture*. London: Harvester-Wheatsheaf, and Chicago: University of Chicago Press.
- Hattie, J., & Timperley, H. (2007). The power of feedback. *Review of Educational Research*, 77, 81-112.
- Hollebrands, K. (2007). The role of a dynamic software program for geometry in the strategies high school mathematics students employ. *Journal for research in mathematics education* 38(2), 164-192.
- Keeley, P., & Tobey, C. (2011). *Mathematics Formative Assessment - 75 practical strategies for linking assessment, instruction, and learning*. Thousand Oaks, CA: Corwin Press.
- Kollar, I., & Fischer, F. (2010). Peer assessment as collaborative learning: A cognitive perspective. *Learning and Instruction*, 20, 344-348.
- Natriello, G. (1987). The impact of evaluation processes on students. *Educational Psychologist*, 22, 155-75.
- Ponte, J. P., Serrazina, L., Guimarães, H., Breda, A., Guimarães, F., Sousa, H., Menezes, L., Martins, M. G., & Oliveira, P. (2007). *Programa de Matemática do ensino básico*. Retrieved from <http://sitio.dgidc.min-edu.pt/matematica/Documents/ProgramaMatematica.pdf>.
- Prensky, M. (2010). *Teaching Digital Natives – Partnering for real learning*. Corwin: SAGE.
- Price, M., Handley, K., O’ Donovan, B., Rust, C., & Millar, J. (2013). Assessment feedback: an Agenda for change. In S. Merry, M. Price, D. Carless and M. Taras (Eds.). *Reconceptualising feedback in higher education – Developing dialogue with students*, (pp. 41-53). London: Routledge.
- Sadler, R. (2010). Beyond feedback: developing student capability in complex appraisal. *Assessment and Evaluation in Higher Education* 35(5), 535-550.

- Santos, L. (2002). Auto-avaliação regulada: porquê, o quê, e como? In P. Abrantes and F. Araújo (Coords.), *Avaliação das aprendizagens*, (pp. 77-84). Lisboa: Ministério da Educação, DEB.
- Smith, I. (2007). *Assessment & Learning pocketbook*. Alresford: Teacher's Pocketbooks.
- Taras, M. (2013). Feedback on feedback: uncrossing wires across sectors. In S. Merry, M. Price, D. Carless and M. Taras (Eds.). *Reconceptualising feedback in higher education – Developing dialogue with students*, (pp. 30-40). London: Routledge.
- Trigo, M. (2004). The Role of Technology in Students' Conceptual Constructions in a Sample Case of Problem Solving. In *Focus on Learning Problems in Mathematics*. Spring Edition, 26(2), pp. 1-17.
- Yu, P., Barrett, J., & Presmeg, N. (2009). Prototypes and Categorical Reasoning: A Perspective to Explain How Children Learn about Interactive Geometry Objects. In T. Crane and R. Rubenstein (eds.), *Understanding Geometry for a Changing World*. (NCTM Yearbook), (pp. 109-125). Reston, VA: NCTM.

SIMULATING RANDOM EXPERIMENTS WITH COMPUTERS IN HIGH SCHOOL LEVEL TEACHING

Bernard Parzysz

Université d'Orléans, France & Laboratoire André Revuz, Université Paris-Diderot

parzysz.bernard@wanadoo.fr

Nowadays the teaching of probability makes great use of software, especially to simulate random experiments. For this purpose spreadsheet is a very useful and necessary tool. This paper studies a type of tasks very widely used in French high school curricula (as well as in other countries), in which spreadsheet is used in turn as a random generator, a logical tool, a calculator and a plotter. To work out such a task students first have to elaborate a model of the situation, then simulate it using the software. Thus they have to move through several probabilistic and statistical paradigms, mostly with no explicit clue to help them identify the suitable one(s), making it difficult to know in which paradigm they are supposed to work, which may result in their mixing up statistical and probabilistic notions. Through an emblematic example I would argue into teachers not overlooking this point.

INTRODUCTION

Through the last century statistics and probability used to be separate chapters in the secondary curriculum (Parzysz, 2003), but a new approach of probability, together with the development of technology for teaching, threw a bridge between them. In French high school curricula the teaching of probability has evolved a great deal from 2010 on, shifting from a purely 'Laplacian' (or 'cardinalist') point of view on the concept of probability (*i.e.* assuming that the elementary events have the same chance of occurring) to a much less dogmatic approach, integrating a 'frequentist' view (according to which the probability of an issue is the 'limit' of the relative frequency of its occurrences through repetitions of the random experiment). This can be in some way compared to the teaching of geometry, since the question of modeling appears to be an important element in both approaches.

Another important fact is that nowadays technological tools play a large role in both domains (*e.g.* dynamic geometry software on the one hand, spreadsheet on the other hand). However, "*it is not good enough to only consider which technology to use, but (...), in order for effective learning to take place, it is how the technology is integrated into the curriculum and learning process and how the teacher uses it that are vital*" (Pratt, Davies & Connor, 2008, p. 98). Some years ago I got an interest in this question about the use of spreadsheet in the teaching of probability at high school level, and especially the use of computer simulation in the modeling process. As Trouche pointed out:

The development of computer tools has largely influenced the development of some mathematical domains (...) and given a new status to experimental features in research (...). These effects apply to classroom mathematics as well. (...) Tools also have a great impact on the way students work. (...) Finally the tools put into play in teaching have thorough effects on conceptualization. (Trouche, 2005 p. 267, my translation).

These recent changes were not without consequence on students' understanding, *e.g.* because they may favour a tendency to blur the distinction between similar notions in one domain and the other. As Girard states, "*teaching probability by modelling and simulation is not easy*" (Girard, 2008, p. 2); he also adds that "*the link between statistics and probability is still to be clarified*" (*ibid.*). And Borovcnik advocates supplying the students with a wider and clearer view on probabilistic notions: "*clarification of the mutual dependencies between frequentist, Bayesian, and mathematical conceptions and intuitive thought makes the concept of probability flexible and robust*" (Borovcnik, 2011, p. 79).

In this paper, in order to bring to the fore some problems which arise from the current situation and indicate some possible ways to overcome them I study how French 10th and 11th grade textbooks deal with computer-aided tasks in their probability courses.

This paper may be considered as an *a priori* analysis of a widespread situation that nearly all high-school students will meet more than once.

THEORETICAL FRAMEWORK

To analyze this type of task I shall use the concept of paradigm coming from Kuhn (1962) and recently applied to geometry by Houdement & Kuzniak (2006). My idea was to transfer these authors' framework to probability, following the parallel made between the two domains by Henry (1999). Thus I defined several probabilistic paradigms which, in a more or less explicit way, are of common use in the teaching of probability at high school level (Parzysz, 2011):

- a 'realistic' paradigm, *i.e.* the concrete experiment put into play using material objects (*e.g.* real dice, coins, lottery wheel, balls in a bag, etc.);
- a second paradigm (P1), resulting from a modeling in which the concrete experiment will result in a list of outcomes and a precise experimental protocol ('pseudo-concrete' experiment) ensuring that the experiment can be repeated in the same conditions, the repetition leading to observe phenomena to which a chance of occurrence is ascribed;
- another paradigm (P2), resulting from a 'probabilistic' view on the experiment, in which the generic random experiment and the notion of probability are defined. Then a study of the properties of probability is undertaken, *i.e.* an algebraic structure is defined about the events, illustrated in classical model laws (binomial, exponential, geometrical, Gaussian...). The related tools are mathematical proof, usual calculation techniques, representation registers (two-way table, probabilistic tree, set diagram, various statistical graphs...);

- a statistical paradigm, namely descriptive statistics (DS), at play in computer simulation, which is also used to establish links with probabilistic notions (relative frequency / probability, arithmetic mean / expected value...). The current French curriculum for 11th grade encourages such a relation: “*By using simulations and a heuristic approach to the law of large numbers, the link will be made with the mean and variance of a series of data*”. [1]

I shall also refer to the notion of workspace (Kuzniak, 2011), that I extended from geometry to probability, with its three components:

- a reality space composed of material objects, associated with a visualization process;
- a set of artefacts (tools, instruments) allowing actions on the objects, associated with a construction process;
- a theoretical reference system, associated with a discursive process (argumentation, proof).

Other theoretical elements have been of interest for me, such as:

- semantic congruence (Duval, 1995), *i.e.* a match between units belonging to two different semiotic registers and a similar organization of these elements.
- instrumental genesis (Rabardel, 1995), *i.e.* what makes a mere tool becomes an instrument through using it.

USING COMPUTERS IN CLASSROOM TO SOLVE PROBABILITY TASKS

Since they are much referred to by teachers, textbooks are a good indication of how computers may be used in classrooms. A survey of the French textbooks for 10th to 12th grades showed that spreadsheets are mainly used to solve two types of tasks:

- tabulating a law of probability,
- simulating a random experiment.

In the first case, a typical exercise shows a picture of a sheet meant to display a random distribution, asks the students some questions about how it was made and then asks to get a graph of the distribution, calculate some associated numbers (expected value, standard deviation...) and vary the parameters. Then the student has to answer some questions and is asked to make conjectures about what he/she could observe. Here the computer is merely used as a calculator, allowing instantly to get results which in olden days would have required a long time (but nevertheless would have been theoretically available).

The second case constitutes the subject of the present study. The French curriculum for 11th grade lays emphasis on this aspect:

Using graphic representations and simulations is essential. (...) Algorithmic activities are undertaken (...). Simulating polls on spreadsheet allows become sensitive to interval estimates. [1]

What is meant here by ‘simulation’ seems clear: it is using a calculator or a computer to simulate a random experiment. The authors of the curriculum have indeed taken into account the expansion of technology, but by this they restrict the meaning of the word, since, as a 10th grade textbook states: “*simulating an experiment is replacing it by another experiment which enables one to get results similar to those of the first experiment; moreover, the new experiment has to be simpler to carry out.*” [2] [1]. The essential difficulty lies in ascertaining that the results will be ‘similar’. In fact, the similarity between the experiment and its substitute can only come from the fact that they refer to the same probabilistic model. For instance throwing a well-balanced coin to play heads and tails may be simulated with a die, by agreeing that getting an even number will mean ‘head’ and an odd number will mean ‘tail’. Assuming that the die is well balanced will ensure that the ‘virtual’ coin is also well-balanced.

Similarly, in order to study how boys and girls are distributed in families with three children, you can put in a bag black and white balls in equal numbers (*e.g.* 10), then remove three balls from the bag one at a time, put each ball back in the bag afterwards and study how many balls of each color you have got. In that case the underlying model supposes that the births of a girl or a boy are independent and occur with the same probability; hence the number of girls in a family will follow a binomial law with parameters $n = 3$ and $p = .5$.

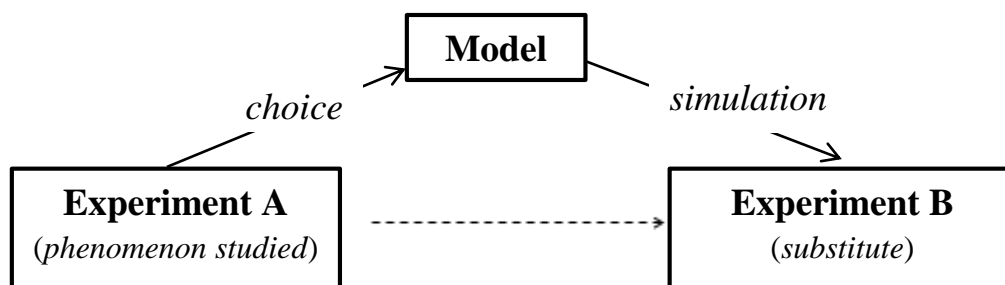

Figure 1

The most frequent type of exercise to be found in French 10th and 11th grade courses and textbooks includes a simulation of a real situation in which several outcomes can occur in an unpredictable way, according to the following process:

- 1° simulating the situation with the spreadsheet
- 2° observing the result of the simulation
- 3° expressing a conjecture about the probability of one of the possible issues of the experiment or about the possible value of a parameter of the situation.
- 4° solving the problem using the probability theory.
- 5° comparing the theoretical results with the results of the simulation.

In order to make my purpose clearer I shall now study a practical work taken from a French 10th grade textbook well used in classrooms [3]. In fact, by now this task has

become a stereotype, since numerous examples of this same practical work can be found in textbooks of that level.

ANALYSIS OF A SIMULATION TASK

The task

Here goes the wording [1]:

(Part 1 [4]) You have three perfect tetrahedral dice: one blue, one red and one green [4]. You throw these three dice and observe how many 4s you obtain.

An outcome is a three-digit number, for instance 1 4 3. It is assumed that the probability for all the outcomes is the same.

Let us consider the following game: if you get the number 4 three times you win 36 €; if you get it twice you win 2 €; otherwise you lose 1 €.

The aim of this exercise is to estimate the average profit which can be expected from a series of 2,500 tries.

(Part 2) Simulate with a spreadsheet

	A	B	C	D	E	F	G
1	Try n°	Blue die	Red die	Green die	Issues of 4	Profit	Average profit
2							
3							

a) Open a worksheet and fill cells A2 to D2 with the appropriate formulas.

b) In E2 count the occurrences of 4 in the block of cells B2:D2. [help: use the instruction COUNTIF]

c) In F2 have the profit of try 1 displayed.

Enter the conditional instruction: =IF(E2=3;36;IF(E2=2;2;-1)). Justify that it suitably describes the rule of the game.

a) In column H you want to display the mean profit as a function of the number of tries. Which formula do you have to enter?

b) Select the block of cells A2:H2, then paste downwards until row 2501.

c) Select columns A and H, then represent the mean profit as a function of the number of tries, n .

(Part 3) Conjecture

Simulate this experiment several times. (...)

How does the mean profit evolve with the number of tries?

Which mean profit can be expected at the end of 2,500 tries?

(Part 4) Proof

a) How many outcomes are there for a try?

b) Count the outcomes giving three 4s; two 4s.

c) Let G be the random variable giving the algebraic profit (in €) of the player. Set up the table of the law of probability of G , then calculate $E(G)$.

(Part 5) What link do you establish between the result of the simulation and the expected value of G ?

Simulation

In Part 1 the ‘concrete’ situation is described: material objects at play, rule of the game, and a question is asked about this game.

The student’s intended workspace is composed of these objects and rules, together with actions (2,500 tries) and subject of interest (mean profit).

Then a hypothesis is made (“It is assumed that the probability for all the outcomes is the same”). In fact, it introduces a probabilistic model of the situation. This going through P1 is necessary, since to simulate an experiment you need to model it. Making the model explicit ensures that the same experiment will be repeated, since in each try the same protocol will occur (Parzysz, 2009). However this necessary step is often skipped in teaching and one shifts directly from the real situation to its simulation. This is made easy because for most of the random experiments studied in classrooms a canonic model exists, which is then considered ‘transparent’. But, by so doing, the students may be induced to simulate the real situation at first, i.e. without being aware that they are implicitly making hypotheses.

In the model presented here, “an outcome is a three-digit number” and, since each die can show 1, 2, 3 or 4 there are 64 possible outcomes which, from the hypothesis, are assigned $1/64$ as probability. The referent workspace (in P1) is composed of the outcomes with their probabilities, and the student is supposed to work within the domain of rational numbers.

The next step of the task (Part 2) is a simulation. One of its current uses in probability teaching is to have the computer carry out a long series of tries supposed to be similar to the random experiment studied. The feature used for that purpose is a (pseudo) random generator supposed to provide decimal numbers equally displayed between 0 and 1 (Parzysz, 2005).

In this part the student’s workspace shifts from P1 to DS: the probability hypotheses have to be converted into instructions for the software, the corresponding registers being natural language and the symbolic language implemented in the spreadsheet. Then the students work within DS, using notions they already know (sum, mean). Implementing the rule of the game in the worksheet is trickier, but the textbook helps them by giving the formula. The students have to elaborate a strategy, and for this they are given clues at each of the three steps which can be distinguished in the strategy:

- 1° dealing with the three dice individually;
- 2° putting the three results in common;
- 3° repeating the experiment.

A major difference with using geometry software for teaching appears here: the students are much more guided, and they are confined to carry out elementary tasks. This characteristic fact has already been mentioned by educators:

A (...) feature of the [computer aided] teaching is the tendency to develop a solution strictly step by step (...) The aspect being important for my concern is not that an order is put on mathematical task solving (...) but that the participants restrict their considerations to the actual mathematical step. (Jungwirth, 2009 p. 3)

Since “*making the handling of software easier does not ensure the necessary ability for succeeding in more complex tasks*” (Rabardel, 1995, [1]), it seems important that the teacher explains the process in its entirety, and for that a diagram visualising the algorithm at work may be most useful.

The justification required at the end of question c) is supposed to make sure that the student understands what he/she is doing, but it is in fact purely rhetorical. Some textbooks pay attention to this question and have devoted paragraphs on how to use calculators, spreadsheet and dynamic geometry software in relation with the tasks required in the curriculum.

In *Part 3* the spreadsheet is used for repeating the experiment and making conjectures based on the results displayed (numbers and diagram). This dynamic aspect is an important feature of the task, because it establishes a link between DS and P2

Until now the spreadsheet had been used in turn as a random generator (for throwing dice), a logical tool (conditional instruction), a copying machine (in order to get 2,500 tries), a calculator (for the average profit) and finally a plotter (to show its evolution). Then it is used for making conjectures. The student’s task is now to observe how the results evolve through several series of experiments and then conclude by making a guess about a ‘limit’ for the parameter. An important feature of the software for teaching is indeed its dynamic aspect (F9 key) which shows the sample fluctuations and the convergence of the frequencies; nevertheless it has some limits, since the – postulated – limit of the series of frequencies is not necessarily accessible, *e.g.* if it is not a decimal number. The student’s workspace is mostly DS, with a – more or less implicit – recourse to a ‘naive wording of the law of large numbers’ [6] which refers to probability.

Finally, this process can be illustrated by the following diagram (figure 2): starting from the real situation, the student shifts to probability (to implement a model in the spreadsheet) then to statistics (to calculate parameters of the distribution), then again to probability (using the law of great numbers to conjecture limits) and finally back to the real situation to express his/her answer.

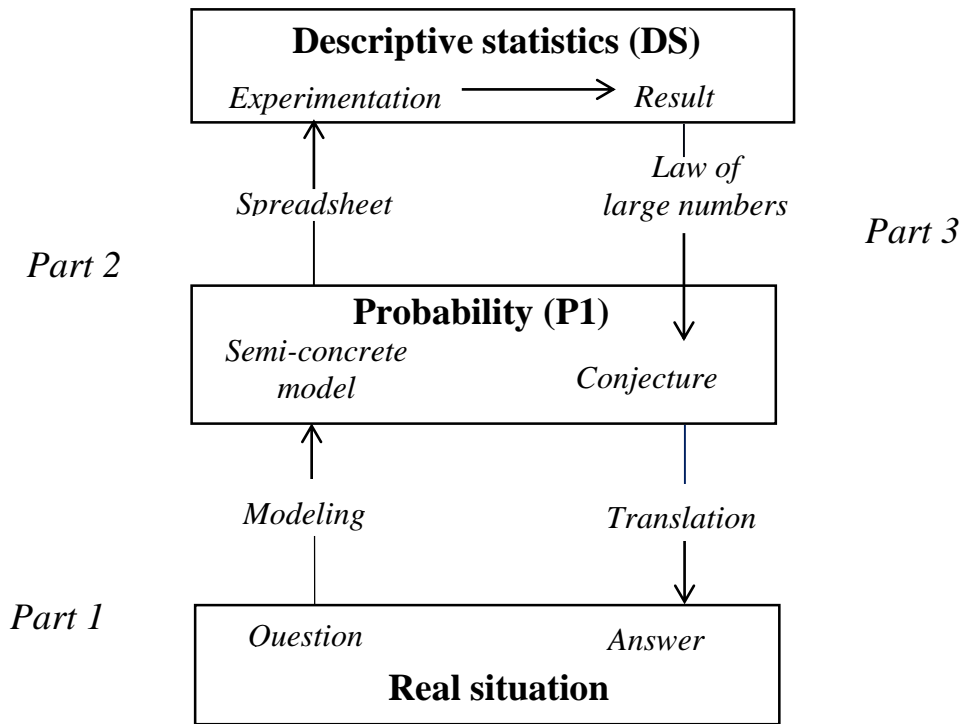

Figure 2

Theoretical solution

Part 4 is quite another exercise, in which simulation is abandoned and a theoretical solution asked. Its structure and wording are that of a ‘classical’ probability problem (P2). The student’s task is to determine in which theoretical space he/she will have to work, then to set up the table of the law of probability of G and calculate its expected value.

The processes at play in this part of the task can be described by the following diagram (fig. 3):

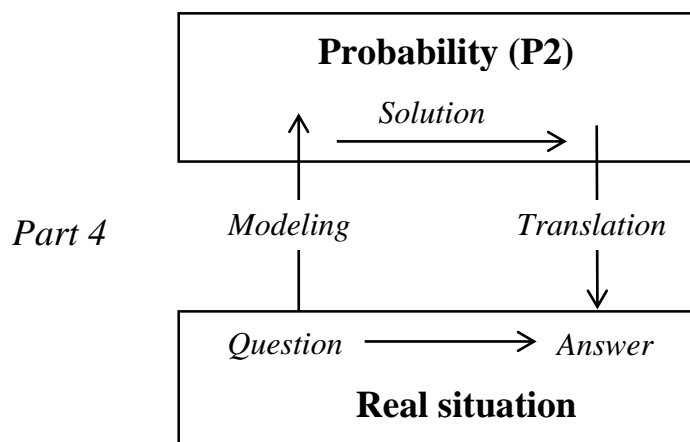

Figure 3

Let us note that the subjacent model is the initial one, in which an outcome is a three-digit number: this is the reason why the dice must have different colors, the aim of such a ‘pedagogical artifact’ being to guide the student towards the correct solution.

Comparison

To finish with (*Part 5*), the student is asked to establish a link between the ‘statistical’ part (simulation) and the ‘probabilistic’ part (proof). The justification will be based on a ‘naïve formulation of the law of large numbers’. But here we have $E(G) = \sum x_i \cdot p(x_i)$, whereas the average profit is $\sum x_i \cdot f(x_i)$ ($1 \leq i \leq 3$). Therefore one has to take into account not only the convergence of a particular frequency but the convergence of the frequency *distribution* towards the probability distribution. This is indeed a consequence of the law, but it makes it necessary to consider the *whole* distribution.

Remark. The purpose of the authors was certainly here to introduce the binomial law, since three independent Bernoulli random variables $\mathcal{B}(.5)$ can be attached to the dice. Moreover, the values of the random variable were chosen so that its expected value is 0 (fair play).

DISCUSSION

About model(s)

Here a question arises about the model, which is far from unusual in probability, especially when spreadsheet is used (Parzys, 2009): the model implemented in the software does *not* fit with the hypothesis. The table shows that the assumed equiprobability concerns the four vertices of each die, since the hypothesis states that it is in the 64 possible three-digit numbers. A more suitable implementation would have been to display the three-digit number together with the corresponding number of 4 and/or the associated profit. Of course in the present case the two models, although different, give the same results. According to the hypothesis, there are 54 outcomes with no or one 4, 9 issues with two 4s and 1 outcome with three 4s. Hence the distribution is: $P(G = 36) = 1/64$, $P(G = 2) = 9/64$, $P(G = -1) = 27/32$.

According to the model implemented, for each die $p(1) = p(2) = p(3) = p(4) = 1/4$. And, assuming that the dice are mutually independent, a binomial law with parameters $n = 4$ and $p = .25$ gives the same distribution as above:

$$P(G = 36) = \binom{3}{3} (1/4)^3 = 1/64, P(G = 2) = \binom{3}{2} (1/4)^2 (3/4) = 9/64,$$

$$P(G = -1) = \binom{3}{1} (1/4) \left((3/4)^2 \right) + \binom{3}{0} (3/4)^3 = 27/32$$

However the first model would have been more difficult to implement in the software and this is certainly the reason why the authors chose another one which they knew would lead to the same results. In fact, there seems to be a general implicit – and efficient – rule according which, when the congruent model is not easy to implement

in the computer, you replace it by another one, equivalent to the first one and easier to set up.

Replacing a model by another one is no problem for the teacher, since he/she *knows* that they are equivalent. But the students could rightly be puzzled by this substitution. In the present case a possible better solution would be to study another experiment, in which a *same* die is thrown three times, the first throw giving the first digit of the number and so on. The table would then be:

	A	B	C	D	E	F	G
1	Try n°	1 st throw	2 nd throw	3 rd throw	Outcomes of 4	Profit	Average profit
2							
3							

A problem appears when students are beginning to study probability, since they do not know what a probabilistic model is. The use of computer simulation can help them grasp this notion, in the following way (Parzysz, 2009): after simulating various random experiments they may become aware that for some of them the procedures implemented are very similar, since the corresponding sheets have the same structure (*e.g.* the above table and the table given in the wording of the exercise). This common experiment scheme can then be used to justify that one experiment can be replaced by another one that will ‘give the same results’ (fig. 4):

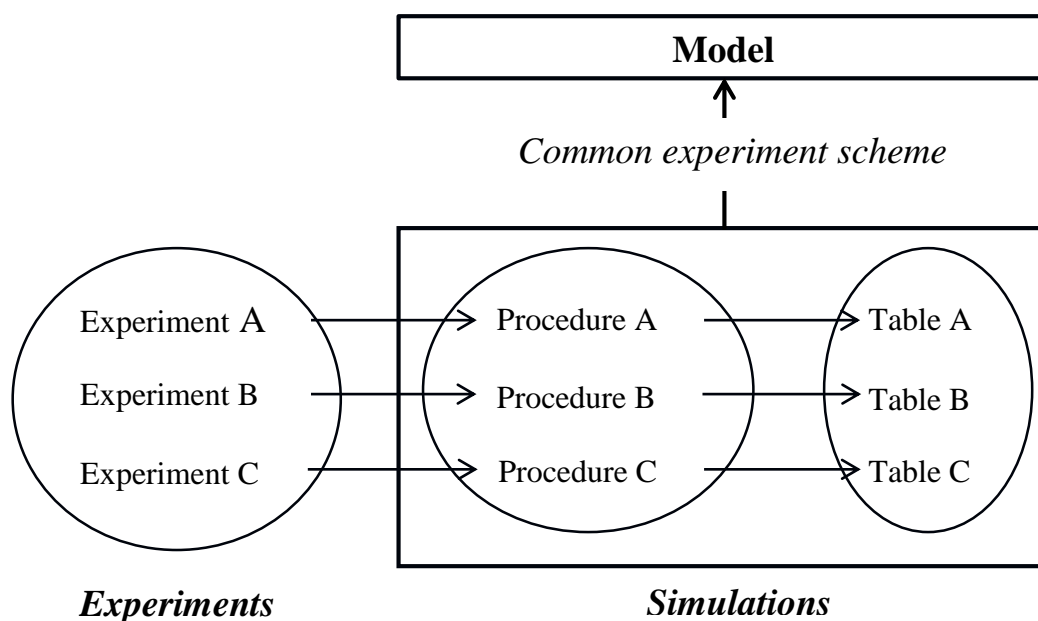

Figure 4

Reality, statistics and probability

As we could see, this task is in fact composed of two quite different exercises, the first one making use of a spreadsheet, and the second one being of a traditional type. What makes it interesting from a pedagogical point of view is the final comparison between

them: it shows that the computer can be used to approximate a law of probability, on the condition that this law is implemented in a correct way in the computer. Here the link between statistics and probability is fundamental, and one must not confuse these two domains: probability is about *theoretical* objects, whereas statistics studies a series of data coming from an *observed* phenomenon. There are of course strong links between them, and some concepts and formulas are very similar, such as for instance:

- arithmetic mean (statistics): $m = \sum f_i x_i$
- expected value (probability): $\bar{X} = \sum p_i x_i$

In the present case, the average profit observed in 2500 tries may be .0426, .0018 or .0235, but the expected value of profit is exactly 0. The wording is confusing, since ‘average profit’ is used both in a probabilistic context (*Part 1*: “estimate the average profit which can be expected”) and a statistical context (*Part 2*: “In column H you want to display the average profit”). Moreover, the meaning of ‘average profit’ in the question “Which average profit can be expected at the end of 2,500 tries?” is really puzzling: if it really means ‘average profit’, after having carried out 2,500 tries you *know* it because you can calculate it; but if it means ‘expected value’ you do not need 2,500 tries to know it, since it is 0. This may give a clue to making the difference between the two domains appear. For instance, when you compare on a screen several experimental graphs issued by simulations of a binomial law with the theoretical graph of this same law, you notice that the statistical graphs are different from one another, and different from the probabilistic graph as well (although they are close to it).

Finally we could see that in such exercises the student is faced with three different experiments: a real experiment (dice), a model experiment (implementation on computer) and a simulated experiment (simulation). These experiments are associated with different reference domains, and thus with different workspaces, and they interact with one another. This is somewhat similar with what happens with geometry problems.

CONCLUSION

In such tasks the process which has to be put into play by students is complex, since they have to deal with several domains and shift from one to another: reality, probability and statistics. The student’s workspace is constantly changing, first through a modeling process – often implicit – then through a simulation on spreadsheet and finally through a return to the model. In this process the computer acts as a versatile help, since it is used in turn as random generator, calculator, logical tool and plotter, both to calculate (and then it produces *results*) and to ‘show’ theoretical results (and then it produces *conjectures*), which may not be so clear for students. In these process three different ‘experiments’ are carried out in turn, each of them belonging to a different domain, and teachers would certainly be aware of the risk of ‘blurring’ the distinction between them:

A dissymmetry between students and teachers must be noted. The latter, who are experts in their domain, directly decode the results which they are presented, without even thinking about it. It is not the case with students in the process of learning, who usually do not have the required knowledge at their disposal. (Bruillard, 1997 [1]).

For that reason the role of the computer is not just to make it easier to get a large number of experiments in a short time (*i.e. tool*) but it constitutes an important element in the modeling process (*i.e. instrument*). This ‘instrumentation’ process needs time, and students must be given the conceptual background enabling them to become familiar with the modeling process to fulfill this goal (Rabardel, 1995).

The semantic congruence between the real situation and the model implemented in the computer has to be taken into account explicitly in teaching. Computer has now become a very useful – in fact essential – help in probability teaching. But its numerous advantages – among which the random generator and the speed for calculation – must be accompanied by a concern for possible problems which may arise from using this medium. As we could see, some of them can be overcome if teachers train their students to become aware of the various domains brought into play by putting the stress on what comes from (real or computer-aided) experiment and what comes from the theory. One aim of this paper was to show which didactical problems may arise from the use of probabilistic simulation; another one was to contribute to make things clearer. But further research should now be undertaken to specify how this can be achieved in classrooms.

NOTES

1. My translation.
2. *Mathématiques classe de Seconde. Collection Indice*. Bordas, Paris 2000, p. 138.
3. *Mathématiques classe de Première. Collection Transmath*. Nathan, Paris 2011, p. 303.
4. This division into five parts is mine; it is intended to make the following discussion easier.
5. The wording is illustrated with a photograph of the dice showing their vertices labeled 1, 2, 3, 4.
6. “When the number of experimentations grows the relative frequency gets nearer the probability” (Cf. *Resource document* for 9th grade, p. 8).

REFERENCES

- Borovcnik, M. (2011). Strengthening the role of probability within statistics curricula. In C. Batanero, G. Burrill, C. Reading, & A. Rossman (Eds), *Teaching statistics in school mathematics. Challenges for teaching and teacher education*. Joint ICMI/IASE Study, (pp. 71-83). New York: Springer.
- Bruillard, E. (1997). L’ordinateur à l’école: de l’outil à l’instrument. In L.O. Pochon & A. Blanchet (Eds), *L’ordinateur à l’école: de l’introduction à l’intégration*, 97-118. Neuchâtel: IRDP.
- Duval, R. (1995). *Sémiosis et pensée humaine. Registres sémiotiques et apprentissages intellectuels*. Bern: Peter Lang.

- Henry, M. (1999). L'introduction des probabilités au lycée: un processus de modélisation comparable à celui de la géométrie. *Repères-IREM* 36, 15-34.
- Houdement, C. & Kuzniak, A. (2006). Paradigmes géométriques et enseignement de la géométrie. *Annales de Didactique et de Sciences cognitives* 11, 175-193.
- Girard, J.-C. (2008). The interplay of probability and statistics in teaching and in training the teachers in France. In C. Batanero, G. Burrill, C. Reading, & A. Rossman (Eds), *Teaching statistics in school mathematics. Challenges for teaching and teacher education*. Joint ICMI/IASE Study, (pp. 1-2). New York: Springer.
- Jungwirth, H. (2009). Explaining a technologically shaped practice: a sociological view on computer based mathematics teaching. In C. Bardini, D. Vagost, A. Oldknow (Eds), *Proceedings of the Proceedings of the 9th International Conference on Technology in Mathematics Teaching*, Metz, France: ICTMT9. Retrieved from <http://ictmt9.org/contribution.php?id=55&lang=en>.
- Kuhn, T. (1962). *The structure of scientific revolutions*. Chicago: The University of Chicago Press.
- Parzysz, B. (2003). L'enseignement de la Statistique et des probabilités en France: évolution au cours d'une carrière d'enseignant (période 1965-2002). In B. Chaput & M. Henry (Eds), *Probabilités au lycée*, 9-34. Paris: ADIREM/APMEP.
- Parzysz, B. (2005). Quelques questions à propos des tables et des générateurs aléatoires. In B. Chaput & M. Henry (Eds), *Statistique au lycée I*, 181-199. Paris: APMEP.
- Parzysz, B. (2009). Simulating random experiments with computers in the classroom: indispensable but not so simple. In C. Bardini, D. Vagost, A. Oldknow, A. (Eds), *Proceedings of the Proceedings of the 9th International Conference on Technology in Mathematics Teaching*, Metz, France: ICTMT9. Retrieved from <http://ictmt9.org/contribution.php?id=89&lang=en>.
- Parzysz, B. (2011). Quelques questions didactiques de la statistique et des probabilités. Strasbourg, *Annales de Didactique et de Sciences cognitives* 16, 127-147.
- Pratt, D., Davies, N. & Connor D. (2008). The role of technology in teaching and learning statistics. In Batanero, C., Burrill, G., Reading, C. & Rossman, A., eds, *Teaching statistics in school mathematics. Challenges for teaching and teacher education*. Joint ICMI/IASE study, Springer, 97-107.
- Rabardel, P. (1995). *Les hommes et les technologies. Une approche cognitive des instruments contemporains*. Paris: Armand Colin.
- Trouche, L. (2005). Des artefacts aux instruments, une approche pour guider et intégrer les usages des outils de calcul dans l'enseignement des mathématiques. In *Proceedings of the Saint-Flour Summer University*, 265-289. Retrieved from http://www3.ac-clermont.fr/pedago/math/pages/site_math_universite/CD-UE/Menu_pour_Internet.htm.

ELECTRONIC FORUMS: AN ADDED VALUE WHEN SOLVING INITIAL ALGEBRAIC PROBLEMS

M. Pilar Royo, Joaquín Giménez

INS Montillivi, Barcelona University

mroyo223@xtec.cat, quimgimenez@ub.edu

Eighteen students of Junior High School (13-14 years old) have been observed when solving a classic algebraic problem in a collaborative way, by using electronic forums. This task is considered as an example to show the interactions appearing when using electronic forums as mediators on the reflective process of co-constructing algebraic ideas. It's found that the highest profile students not only participate actively in the task but they introduce more mathematical meaningful issues. Qualitative analysis shows that generalization methods are close to which it's regularly presented in face-to-face classrooms but reflection spontaneously emerges as a need for revealing the importance of exchanging the representations.

INTRODUCTION

According to traditional perspectives on algebraic teaching, mathematical context is taken as the starting-point while the applications of algebra (like problem solving or generalizing relations) come in the second place. Teachers in traditional classes give a lot of information, while teachers in the reformed classes chose to draw information out of students by presenting problems and asking questions. According to Coll (2007) various studies show that the effective capacity of ICT to transform the dynamics of work of teachers and students in schools and the processes of teaching and learning in the classroom is, in general, far below the transformer and innovative potential, usually attributed to them. In such a framework, our main hypothesis is that the forum of conversation, as a Computer-mediated Communication (CMC from now), can turn out to be a useful instrument to solve, reflect and discuss problems jointly. The challenge is for teachers to create learning environments that help students to make the transition from basic to high-order skills. In this new scenario, the focus is not on teachers but the process of how the students learn. In such a framework, the use of ICT in first Secondary Schools will entail the gradual disappearance of the limitations of space and time, which will result in a transition toward a usual student-centered model based on cooperative work.

Online discussion forums are web-based communities that allow users to share ideas, post problems, comment on posts by other users and obtain feedback. Previous research experiences, uses forums to promote debate and thinking in prospective teachers learning (Bairral & Giménez, 2004; Bairral & Powell, 2013), but less use is devoted to a common problem solving activity with young students (Murillo & Marcos, 2011). Though students are more and more confident in their technical abilities for online

communication, we know that their online experiences do not generally require them to use dialogue as a way to explore, expand, and drill down into problem solving issues significantly (Jonanssen, 2002).

In this paper, our aim is to present how a group of eighteen students of Junior High School (13-14 years old) interact and solve a classic algebraic problem in a collaborative way, using ICT tools as an example for basic scientific understanding of interactions as co-construction processes of sense making in online environments or mixed environments. In particular, to see which is the relation between the use of media tools and problem solving approach. By analyzing such a task, we explain some benefits and possibilities of online algebraic problem solving teaching issues, focusing on the implications of forum conversations as a mediator for reflective interactions. The activity leads to the development of generalization and symbolism processes. The “listening” of the ideas and reasoning of the students allows the planning of activities in order to promote individual learning and the learning of the group.

The condition of transformation agents assigned to the ICT is worth to be taken into account for conceiving deliberate interventions to change the pedagogical models, the practices in the classroom, and the curricular contents in educative systems in order to lead the students towards a significant and satisfactory learning (Rojano, 2003: 138).

THEORETICAL BACKGROUND

We assume that running online discussion forums enable the application of constructivist learning issues for problem solving (Jonanssen, 2002). In our assumption, Teachers have to guide the pedagogical setting towards situations in which relevant aspects are discussed, such as posing questions related to the critical analysis of contexts or the necessity for the generation of new and useful information to promote attention (Ainley & Luntley, 2007).

On-line forums and blogs have also been recognized as fertile ground for meaning product discussion. Some recent researches analyzes forum discourses with preservice teachers or in training teachers courses (Bairral & Gimenez, 2004), and also collaborative problem solving activities with future teachers (Bairral & Powell, 2013). But a few researches focus on what kind of behavior and strategies appear when young students solve algebraic problems in an asynchronous way.

Generally speaking, the use of the Internet in a student-centered model has a great deal of potential strengths: (1) computer networking facilitates the implementation of cooperative learning overcoming the relation human-media (Borba & Vilareal, 2005); (2) promotes articulated communication by compelling the students them to state their needs in a concise and highly articulate way (Royo & Giménez, 2008); (3) Asynchronous web-based forums give students time to reflect on issues before they add their own contribution (Bairral & Powell, 2013); (4) accommodate the potential for e-tutors and e-learners to engage in continuing tutorials, rich in dialogues and reflections, and generate processes of meaning construction and knowledge

advancement (Rowentree, 1997); (5) gives specific opportunities for co-construction of learning (Royo, 2012). In particular, using forums allows students to become the center of their own learning (Jonanssen, 2002).

Participation in our analysis of reflective interactions should be considered as something that improve or restrict mathematics development (Cobb, P. et al., 1997, p. 272). When analyzing interactions we want to understand if the media facilitate mathematical discourse and scaffolding by providing direct instruction (Anderson, 2001). We assume some previous research results about the use of electronic forums with geometry problems (Murillo & Marcos, 2011) that the use of the forums of conversation in a digital environment, used to jointly investigate algebraic problem-solving strategies, create favorable conditions, (a) so that the process of problem solving promote reflection and communication of ideas among the students; (b) for influencing changes affecting the teaching role and the relations that are set out in the classroom; (c) individual growing and collective development of objects and processes in the topic. Several authors tell us that such e-activities based on group work must be properly structured to avoid the free rider effect, but we decide to use the forums in a completely free way (Johanssen, 2002).

For analyzing the educational influence of interactions on electronic environments we consider two dimensions: the academic task management and the management of the meanings. It's considered the construct called educational profile, which relates quantitative contributions data by accessibility, participation and connectivity criteria (Coll, Mauri, & Onrubia, 2012). We also assume that content analysis helps to categorize students interventions in algebraic settings. Many cognitive results are not in this paper, but fully described and justified in Royo (2012). It was also considered that the inscriptions of individuals working online in a small-group or team provide observers, who must interpret meanings constituted in the contributions, as evidences of individual and collective thinking (Bairral & Powell, 2013).

METHODOLOGY

The task presented in this paper, belongs to a part of a wider research *in which several problem solving tasks were conducted, analyzed and redesigned* through the application of a *Design-Based Research methodology* (Gravemeijer, 2002, Royo, 2012). For the design of the learning environment (Murillo & Marcos, 2011), we used the Moodle-platform provided by the School. This paper analyzes just a simple problem, and their conversation forums on the virtual environment Moodle, which was new, both for teacher and students at that moment (see figure 1). The experiment presented in this paper was developed during two months, the year 2008/09 and repeated in 2010 and 2011. In order to see an example of the forums, we focus on the following problem: "Given n dots, how many segments do we need to unite them in pairs?" We choose this problem, because is the first one in the global project, and means a classic in the work of generalization. Wiki spaces were also used to introduce more final reflections, not analyzed here.

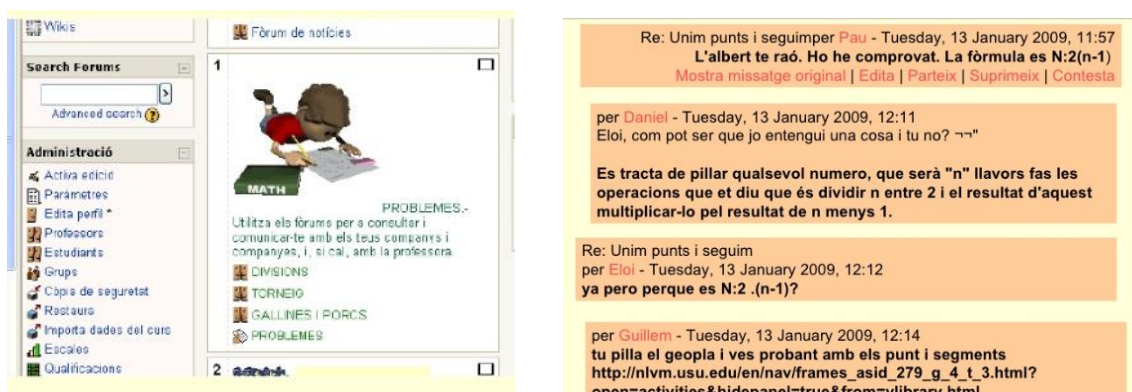

Figure 1. Presentation page (left) and contributions of the forum (right).

Such a problem allows a wide variety of representations and the development of inductive processes, starting with particular cases. Oral conversation occurred in the classroom at the same time that they did contributions to the forums. In addition to using computers, students had paper and other material written or manipulative aids as instruments of work to look for strategies for resolution of the problems. The use of the forums in situation of non attendance and outside the assigned hours (from home, library...) was optional.

The participants communicated individually among themselves simulating to be at home in a computer room, and combining it with group of four discussions in the regular face-to-face classroom. At the end of the intervention period in forums, students carried out a written test and answered a survey for the evaluation of the use of electronic conversation forums. The collected data for our study is constituted by *registered* dialogues on the forum, and also audiovisual records of some moments of the session; direct records of the diaries of the students in the Moodle platform; record direct from the journal of the teacher in the Moodle platform.

We have analyzed the dialogues of the forums by applying descriptive methods to its development during the sessions, including aspects of activities that have had impact on them. We think that it should lead the mathematical reasoning through observation of individual cases, guess, check and argumentation, since thus prepares the task of orientation of the process of generalization, one of the main ways of introduction of the algebra. To follow our aims, student's interactions had been analyzed by using educational profile using e-accessibility and e-connectivity. Content analysis is presented here by identifying algebraic contributions in a specific task, and quantifying the use of problem solving strategies in terms of applying and answering, grounding, or interpreting other's contributions.

To describe the steps and strategies used, we considered the following categories (following J. Mason et al., 1985): (V) Students verbally explicit relationships between the data of the problem. (PA) Used arithmetic procedures to express relationships between the data of the problem. (LIS) Used symbolic language to express relationships. (RP) Records a pattern or regularity, preferably using symbolic language in which formula appears in accordance with symbolic expressions, including ways to

iterative and recursive procedures. (PVF) if students prove the validity of the formulas used.

RESULTS

To see the results of our first structural interaction analysis of contributions within the DBR process, we selected and adapted a set of e-communication indicators (following Coll, Engel & Bustos, 2009). Expected profile considers: (a) accessibility by individual average of entries being > 1 and individual entries $\geq 1/n$; (b) participation by observing individual contributions in front of readings being $\leq 0,5$ and individual contributions in the total being $\geq 1/n$; (c) connectivity by seeing number of messages received out of the whole $\geq 1/n$, and number of messages received over sent being almost 1 (d) collective accessibility being everyday average of entries $> n$; tax of contributions being $\leq 0,5$. In Table 1 we show how the first four groups of the 18 participants which were grouped according to the highest number of above cited criteria satisfied.

Table 1. Profile and interaction characteristics found in the problem analyzed.

PARTICIPANTS <i>Students</i> <i>Teacher</i>	N DOT PROBLEM (individual indicators)					
	ACCESS		PARTICIPATION		CONNECTIVITY	
	Individual average of entries MDIE ($>1?$)	Individual indicator of entries— IIE ($\geq 1/n$)	individual indicator of contribution relating lectures— IIRCL ($\leq 0,5$)	individual indicator of written contributions — IIC ($\geq 1/n$)	individual indicator of received messages— IIMR ($\geq 1/n$)	Individual indicator of reciprocity— IIR (≈ 1)
St 1_E14	20	0,23	0,17	0,21	0,26	0,83
St 6_St 9	6	0,07	0,24	0,09	0,13	1,00
St 8	12,6	0,15	0,11	0,09	0,12	0,90
Teacher	5,57	0,07	0,21	0,07	0,13	1,25
Profile A Satisfying all the criteria with expected indicators (Highest profile)						
St 5	8	0,09	0,11	0,05	0,08	1,00
Profile B Satisfying five criteria						
St 11	5,71	0,07	0,20	0,07	0,01	0,13
Profile C Satisfying four criteria						
St 2	5,86	0,07	0,12	0,04	0,01	0,20
St 12	1,71	0,02	0,33	0,03	0,05	1,00
St 15	4,86	0,06	0,09	0,03	0,03	0,67
St 16	6,43	0,08	0,13	0,05	0,01	0,17
Profile D Satisfying three criteria						

We have classified the contributions into groups of students depending on whether its focus is the algebraic content or the relationship with the other participants (see table 2, below), and we see that it changes according tasks (Royo, 2012). We found that in the electronic forums, students passed through the access/motivation and online socialization stages to the information algebraic exchange stage in a few days during the analyzed forum as we can see next when describing the example of the first

dialogue. An interaction scheme shows three main nodes for this task, but a lot of common interventions (explained in detail in Royo, 2012, p. 212).

Next, we describe some dialogues of this first task, to see how the dialogues introduce problem solving issues among interactions and how they were codified and associated to each contributor. In their first interventions, the students showed that teacher guidance was still desirable.

Student 1: Pili, which number is n???

Student 2: We can unite nothing because we don't know how many dots we have.
Teacher: Well, maybe we can start with a few dots... How many dots you want to start? (Assume V)

The second part of the Forum starts from a contribution in which St 6 and St 9 vary referential perspective to propose a new strategy to find the sum of n consecutive natural numbers (PA). The teacher proposal offered some security when attempting to begin to draw diagrams with some groups of dots. Therefore, she decided to make a new proposal:

Teacher: You have been drawing dots and segments. You have tried with 2 dots, with 8 dots... Is it possible that you make a table with the results?

Then, many students follow the suggestion, and ordered the data in a table (PA). Others simply accept. This action facilitated the passage from the particularization to the generalization, a process that each student understands as a compulsory proposal. As usually in face-to-face classrooms, the development of tables gave rise to the emergence of recursion strategies.

<i>dots</i>	<i>segments</i>
1	0
2	1
3	3
4	6
5	10
6	15

Student 3 says that “I have found this: the difference between 1 and 2 is one. Between 2 and 3, it is 2. Between 3 and 4, it is 3. And so on... a is the number of segments $a = n - 1 + a$ of previous number.” (PA)

This kind of contributions gave rise to the expression of diverse ideas, request for clarification and comments. It is interesting to observe the last expression of the written contribution above (“ $a = n - 1 + a$ of the previous number”), which are not valued as wrong but as a step in the use of algebraic language. (LIS)

The teacher-researcher wrote in her research diary some comments on content analysis, using different categories: “They have decreased the contributions posed questions (D). They have increased the social contributions (S) and explanations (E). In terms of strategies, they appear for the first time contributions of registration pattern (RP) and evidence of the validity of formulas (PAV). Communication of cognitive elements appearing in some interventions mixed with emotional and affective elements. As an example, St.13 participates for the first time, after having refused initially to use the Forum. The teacher had been talking with him individually after the first session”.

Finally, the students also commented in their written forum reports that they thought the forum allowing active processing, mediated contribution, and a better understanding and control of the problem solving process. In order to facilitate the communication of these expressions, the teacher suggested an oral discussion and the use of the whiteboard to represent the situation jointly developed (see figure 2).

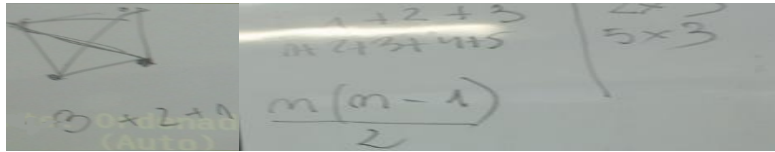

Figure 2. From the particular cases to the generalization.

At the end of the oral discussion, in the forums, new representations appeared:

Students 4 & 5: We have discovered the formula. It works with our examples.
It is: $n:2 (n-1)$ (LIS)

The input to the forum continued. The students kept their communication by requesting and offering explanations and help, or exchanging their findings:

Student 6: [to Student 7] Is it possible that I understand a thing that you don't? $\neg \neg$ "
The question is to catch any number, which will be "n", then you must split between 2 multiply by the result of n minus 1. (LIS+ RP)

Student 8: Albert is right. I checked it out. The formula is $n:2 (n-1)$ (LIS+ RP)

From here, a discussion arose about the equivalence between the expressions " $(n-1), n:2$ " and " $n+(n-1)/2 * n$ ".

Student 4: We can do both things and it goes well. (Example of agreement)

Some students proposed the use of known resources:

Student 9: We can take the geoboard and go testing with dots and segments
http://nlvm.usu.edu/en/nav/frames_asid_279_g_4_t_3.html?open=activities&hidepanel=true&from=vlibrary.html (non cognitive comment)

Some other students sought convincing explanations to the formula. Although this explanation had already been found a week earlier, the attribution and appropriation of meaning has to be performed individually, and each student needs to perform an individual process:

Student 10: Why the formula works: It is because each dot matches with another one, but not with itself. So, you have to subtract 1 from the starting number: $\cdot(n-1)$. The result is divided by 2 because the dots are listed only once. (RP)

Meanwhile, new representations emerged:

Student 11: Me and [Alumn.12] have discovered: When $n= 5$ dots: $(5-1) + (5-2) + (5-3) + (5-4) = 4 + 3 + 2 + 1 = 10$ segments (we are still investigating)

This latest contribution led to the introduction of manipulative material (polycubes) to encourage representations (see figures 3a and 3b) and oral discussion about them:

Teacher : Which relationship do you see in $1 + 2 + 3 + 4 + 5$ in this new context (polycubes)?

[Students: It's the same]

[Teacher : Can you find a formula for it?

[Students: Yes, it's the sum of the "squares"] (PA)

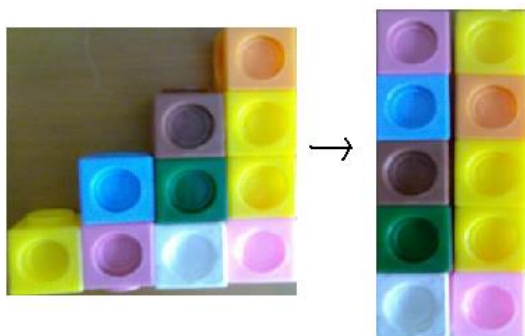

Figure 3a: Representing $1+2+3+4$.

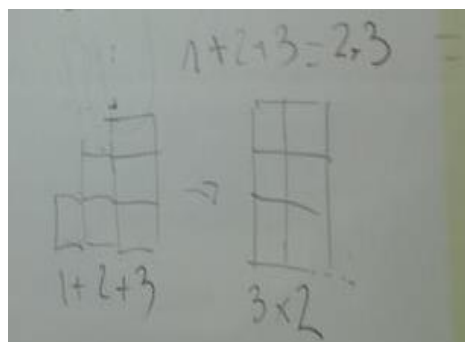

Figure 3b: Representing $1+2+3+\dots+n$.

After the work with material and some discussion, the students returned to the forum. New representations and relationships appeared, as we can observe by Student 13 comment.

Student 13: Another strategy: “5 dots and $n=4$: $1+2+3+4 = (1+4) + (2+3)=5+5= 10$, and that's equal to: $(1 + 4) \cdot 4/2= 5 \cdot 2= 10 (1+n) \cdot n/ 2$ ” (LIS)

After doing all codifications when some strategies and categories appeared, some tables had been constructed to identify what happens in each task. In table 2, we present part of the data research table in this task of n dots we analyze here. It's possible to see the categories above explained and codified as we see in the dialogue. In the table 2, we see the contributions not related to algebra but including possible clarification issues (a); and related to algebra over a colleague contribution (b).

Table 2. Part of classification of contributions in the task according the content, according to different students and profiles.

Problem “n dots”		Categories of contributions								Total	(a)	(b)
Participants	Profile	S	D	V	PA	E	LIS	RP	PVF			
St 1 St 14	A	4	4	1		9	1	4	1	24	7	17
St 2	C	2	1			1	1			5	1	4
St 3	F	1	2					1		4	1	3
St 4	E	6	3		1					10	1	9
St 5	B	2				2	1		1	6	2	4
Teacher	A		2		1	5				8	1	7
Total group		34	28	1	6	26	9	9	3	115	28	87

Finally, to see the influence of educational profile on the final results, we observe how the students in highest profiles evolve in some algebraic meanings. Analyzing the results from all the tables associated to the different tasks and final test, we observed that the categories corresponding to the higher level of algebraic content are related to the contributions of higher educative profile students. Just the Student 16 is different, perhaps his comments are not enough understood by the colleagues.

DISCUSSION

The value of technological tools such as virtual learning environments is not to replace the role of the teacher, but enhance the distributed teaching presence, creating a context that promotes the understanding and development of growing significant algebraic knowledge. In our study we introduced a theoretical tool called “educational profile influence” that served to explain how evolve the interactions in each task as it is in the example. Content categories (as we see in our example in table 2) also were helpful to analyze if the interactions are focused on certain aspects of problem solving activity. Such tools provide the possibility to understand how the interactions relate the educational profile with algebraic content issues and strategies.

If we look not only the example, but the global amount of results and problems, we observe that electronic forums act as agents of change that affected the teaching role and in the relationships and interactions established in the classroom. In particular, highest profile students correspond to the highest problem solving contributions. We also found that in almost all the tasks, electronic forums enable individual and collective construction of objects and processes in the learning of algebra (Royo, 2012), and improve generalization attitudes, similar to face-to-face conversations. Interlocution interactions yield different outcomes and influence the development of mathematical ideas and reasoning in diverse ways. Its use allows: (a) to facilitate guided construction of objects and processes in the learning of algebra (as generalized properties or inquiry methods), encouraging ideas partially developed and without rushing off to get results; (b) to promote the cognitive and linguistic capacities of the students, encouraging them to reflect on what they learn and to express what they know; (c) to develop the communication of mathematical ideas. (d) to develop an increasing use of formal language from problematic situations. (e) to stimulate the ability to share and compare ideas; (f) to stimulate joint construction of meanings; (f) to set the thread around which other activities are developed that also become part of the teaching and learning process. Some of these results are consistent to which were considered in other geometrical problem solving e-studies (Murillo & Marcos, 2011).

It can be expected that all students participate in forums significantly, although as with all educational action/profile, some cases require guidance or teaching intervention to adjust the conditions of participation. In didactic programming it may be convenient to include participation in forums such as evaluation activity. The use of the forums in the joint resolution of algebraic problems facilitated reflection during time, access to

different points of view or contributions, review of what you try to communicate, raise questions and request or offer help or clarification.

Qualitative analysis shows that generalization methods are close to which it's regularly presented in face-to-face classrooms and spontaneously emerges a need for revealing the importance of exchanging the representations not always usual in face-to-face classrooms. These features have also been evaluated positively by the students and the teacher. In addition, the students read messages from other participants even when they have not spoken with contributions. At the end of the forum, it is important to provide a new step to be seen to be appreciated transfer programming made.

CONCLUSIONS

Cognitive and content analysis was not fully explained in this paper, but we observed that almost all students have participated in the forums in a significant way introducing algebraic contributions (Royo, 2012). Although it is not usual, if any student is not involved in a forum with interventions, you would expect that their participation consist of reading the contributions of others. When it doesn't, there are external causes that should be considered (absence...). Or maybe there are grounds which require teacher intervention. We have seen that at the start of the forums the largest number of contributions raise questions or request clarification, but later on, there are more and more algebraic features present during the conversation.

Interactional data corroborate the findings of authors who point out that these instruments allow reflection during the time necessary, giving opportunities to have access to different points of view or contributions of the members of the group, or review what you try to communicate before sending it. They combine features of spoken and written discourse which can facilitate collective learning (Murillo & Marcos, 2011).

Comparing the results presented here with the global research study, we have seen that with 13-14 years old students, the use of electronic forums has been compatible and effective when combined with face-to-face classroom methods. This leads to question the asynchronous use that is usually given to these tools. It makes emerging features of the electronic speeches while synchronous (DES) and asynchronous (DEA) which are combined in a peculiar way offering features that should be considered: If treated properly in the school context, they allow overcoming some difficult or limiting aspects of one and other speeches when performed separately, as it was observed in other subjects (Coll, Mauri, & Onrubia, 2012).

According to global data for all the problems during the broader study (Royo, 2012), the number of contributions with a focus on the algebraic content is significantly less than the contributions with a focus on the relationship with other participants. However, the ratio varies significantly depending on the problem that it was discussed in the Forum. We found enough evidences to tell that the interlocutions observed support the reflective development of the participants' mathematical ideas and

reasoning (Bairral & Powell, 2013) sharing multiple unexpected representations as manipulatives (not related to web environment, and usually presented inside the task). Because of lack of space, we don't explain here the results of the achieved scaffolding process (Anderson, 2001) built in the environment.

This study also present an example contributing to describe some values of using technological resources for analyzing the role of interactions in teaching practice for teacher training preparation of future Secondary Mathematics teachers.

ACKNOWLEDGMENT

This work was partially funded by the project I+D+I EDU2012-32644 of the Ministry of Science and Competitivity of Spain. We also receive funds from GREAV-ARCE 2014.

REFERENCES

- Ainley, J., & Luntley, M. (2007). The Role of Attention in Expert Classroom Practice. *Journal of Mathematical Teacher Education*, 10, 3-22.
- Anderson, T. (2001). Teaching in an online learning context. In T. Anderson (Ed.). *The theory and Practice of Online Learning*. (pp. 343-365). Athabasca, Canada: Athabasca University Press.
- Bairral, M. & Giménez, J. (2004). Diversity of geometric practices in virtual discussion groups. In *Proceedings of PME 28, vol. I*, p. 281.
- Bairral, M & Powell, A. (2013) Interlocution among problem solvers collaborating online: a case study with prospective teachers in *Pro-Posições* v. 24, 1(70) jan./abr.,1-16.
- Borba, M., Vilareal, M. (2005) *Humans-with-Media and the Reorganization of Mathematical Thinking*. New York, NY: Springer.
- Coll, C., Engel, A. & Bustos, A. (2009). Distributed Teaching Presence and Participants' Activity Profiles: a theoretical approach to the structural analysis of Asynchronous Learning Networks. *European Journal of Education*, 44(4), 521-538.
- Coll, C., Mauri, T., & Onrubia, J. (2012). *El papel del profesor en las redes asíncronas de aprendizaje*. Departamento de Psicología Evolutiva y de la Educación. Facultad de Psicología. Universidad de Barcelona.
- Cobb, P., Boifi, A., McClain, K., & Whitenack, J. (1997). Reflective Discourse and Collective Reflection. *Journal for Research in Mathematics Education*, 28(3), 258-277.
- Gravemeijer, K (2002). Emergent modeling as the basis for an instructional sequence on data analysis, In B. Phillips (Ed.), *Developing a Statistically Literate Society. Proceedings of the International Conference on Teaching Statistics [CD-ROM]*. Cape Town, South-Africa, July 7–12.

- Jonanssen, D. (2002). Engaging and supporting problem solving in online learning. *The quarterly Review on Distance Education*, 3(1), 1-13.
- Mason, J., Graham, A., Pimm, D., & Gowar, N. (1985). *Routes to Roots of Algebra*. Milton Keynes: The Open University.
- Murillo, J., & Marcos, G. (2011). Un modelo para potenciar y analizar las competencias geométricas y comunicativas en un entorno interactivo de aprendizaje. *Enseñanza de las ciencias: revista de investigación y experiencias didácticas*, 27(2), 241-256.
- Rojano, T. (2003). Incorporación de entornos tecnológicos de aprendizaje a la cultura escolar: proyecto de innovación educativa en matemáticas y ciencias en escuelas secundarias públicas de México. *Revista Iberoamericana de Educación*, 33, 135-165.
- Royo, P. (2012). *Coconstrucción de conocimiento algebraico en el primer ciclo de la ESO mediante la participación en foros de conversación electrónicos* (Unpublished PhD Thesis). Universitat de Girona.
- Royo, P. & Giménez, J. (2008). The use of virtual environments for algebraic co-construction. In S. Turnau (Coord.), *Handbook of mathematics teaching improvement: professional practices that address PISA* (pp. 75-82). Kraków: University of Rzeszów.

PRESERVICE HIGH SCHOOL TEACHERS' CONSTRUCTION AND EXPLORATION OF DYNAMIC MODELS OF VARIATION PHENOMENA

Manuel Santos-Trigo*, Matías Camacho-Machín**, Carmen Olvera-Martínez*

* Cinvestav – IPN, ** University of la Laguna, Spain

msantos@cinvestav.mx, mcamacho@ull.edu.es, mcolvera@cinvestav.mx

This study aims to analyse and document ways of reasoning and sense making activities that prospective high school teachers developed as a result of working on problem solving sessions that enhanced the use of digital tools. To what extent do prospective high school teachers develop knowledge, resources, and a disposition to engage in reasoning and sense making activities in problem solving sessions that foster the use of technology? How does the participants' tool appropriation process take place and shape their problem solving behaviours and disposition to use the tools? Participants recognized and valued the use of tools affordances to construct and explore dynamically the tasks. Thus, they relied on a set of heuristics (measuring attributes, dragging or finding loci) to explore, and interpret the tasks solution.

INTRODUCTION

The significant developments and increasing availability of digital technologies have opened up new routes for individuals to participate and reflect on science and society issues. In education, technology is challenging traditional curriculum proposals and ways to foster and assess students' learning. Dick & Hollebrands (2011) recognize that "technology is an integral part of modern society and the workplace... But while mathematics has been an indispensable tool for advancing research and development of new technologies, the mathematics classroom itself has been slow to take advantages of using technology in the service of advancing mathematics learning" (p. xi). Recently, main institutions in the USA have launched an online-learning experience that includes online courses and a platform to investigate how the use of technology can transform learning (www.edx.org). The core issue in mathematics education is to analyze the extent to which the systematic use of several digital technologies offers learners new opportunities to understand and develop mathematical knowledge.

Hoyles & Noss (2008) suggest that the incorporation of technologies in the students' mathematical learning implies discussing what types of transformations bring their use to the mathematical knowledge: "[The uses of] digital technologies disrupt many taken-for-granted aspects of what it means to think, explain and prove mathematically and to express relationships in different ways (p. 87). Thus, it becomes important to explain what type of mathematical activities including ways of reasoning learners develop as a result of using digital tools during students' learning experiences. In this study, we focus on analyzing ways in which a group of nine prospective high school

teachers develops and uses technological knowledge (tools appropriation) to construct and extend both subject and didactical knowledge. Specifically, we analysed the participants problem solving approaches when they solve a task that involved modelling a variation phenomenon. In this context, they construct cognitive schemata to transform a technological artifact into a useful instrument to represent, explore, and solve mathematical tasks or problems.

CONCEPTUAL FRAMEWORK: FOCUS ON REASONING AND SENSE MAKING

Prospective high school teachers need to construct a broad conceptualization of mathematics to frame learning activities within contexts that involve dealing with daily problems (mathematics for life); facing and developing problem solving skills (mathematics for the workplace); and developing ways of thinking consistent with mathematics practices and technological developments. The National Council of Teachers of Mathematics (NCTM) (2009) proposes to focus on reasoning and sense making activities as the foundations and cornerstone of the high school mathematics curriculum and its implementation: "...[R]easoning can be thought of as the process of drawing conclusions on the basis of evidence or stated assumptions" (p. 4). It is also recognized that reasoning in mathematics can take many forms ranging from informal or empirical explanations to formal justifications and proofs.

Sense making is a key activity for learners to develop conceptual comprehension and problem solving proficiency: "We define sense making as developing understanding of a situation, context, or concept by connecting it with existing knowledge" (NCTM, 2009, p. 4). Thus, reasoning and sense making activities are essential for learners to develop and exhibit interrelated mathematical processes such as problem solving, representations, and communication while they develop mathematical concepts or tasks.

Schoenfeld (2009) reviewed the NCTM Focus in High School Mathematics: Reasoning and sense making document, and pointed out that the examples discussed throughout it are useful for teachers to illustrate ways to approach the high school content and to organize the students' classroom interactions: "...the mathematics that emerges seems reasoned and reasonable, rather than arbitrary". He goes on to say that the reasoning and sense making approach is consistent with his definition of teaching for problem solving: "The mathematics studied should emerge as a reasoned and reasonable, rather than arbitrary" (p. 170). How can we frame the systematic use of digital technology in mathematics instruction that focuses on a reasoning and sense making approach? Delving into this question involves paying attention to both: The appropriation process shown by learners to transform an artefact or device into an instrument to comprehend concepts and represent and solve problems (Trouche, 2004); and to characterize ways of reasoning that learners develop as a result of using particular tools. "Using technology to display multiple representations of the same problem can aid in making connections...When technology allows multiple

representations to be linked dynamically, it can provide new opportunities for students to take mathematically meaningful actions and immediately see mathematically meaningful consequences—fertile ground for sense-making and reasoning activities” (NCTM, 2009, p. 14). Similarly, Dick & Hollebrands (2011) pointed out the importance for students to use technology as a means to foster problem-solving habits during the entire solution process that involves:

Analyzing a problem: identifying which technology tools are appropriate to use and when to use them

Implementing a strategy: making purposeful use of the technology and monitoring progress toward a solution

Seeking and using connections: especially looking across different representations

Reflecting on a solution to a problem: considering the reasonableness of technology-derived results, recognizing the limitations of the technology, reconciling different approaches (both with and without technology), and interpreting the results in the context of the problem (Dick & Hollebrands, 2011, p. xiii)

Thus, to characterize the participants’ ways to approach the task, we focused on analysing ways of reasoning and sense making activities that emerge or the prospective teachers exhibit when they use systematically the tools in problem solving episodes that include task comprehension, design and implementation of a solution plan, connections and task extension, and looking back at the entire solution process (Santos-Trigo & Camacho-Machín, 2009).

METHODOLOGICAL COMPONENTS AND PROCEDURES

Two main intertwined phases were relevant during the design and development of the study. One in which the research team examined the tasks in detail in order to identify different ways to represent, explore and solve each task. This phase provided information to identify potential questions to orient the participants’ approaches to the tasks (Sacristan et al., 2010). As result of this analysis, an implementation guide for each task was designed. The second phase involves the actual implementation of the tasks. Here, the participants worked on the tasks individually and as group.

A. A prior analysis of the tasks. The research team worked on and discussed each task previous to its implementation. The goal was to identify different ways to represent and explore the problem that led us to the design of an implementation guide that was given to the participants. The guide includes ways to introduce the participants in the use of the tool, in this case the appropriation of a dynamic geometry environment (GeoGebra or Cabri-Geometry). The idea was that they could think of the tasks as learning platforms to engage in continuous mathematical reflections and discussions associated with different ways to approach and extend the tasks. Specially, it was important to show that routine tasks could be transformed into a series of problem solving activities that foster mathematical reflection (Santos-Trigo & Camacho-Machín, 2009). An example of this task analysis is shown next:

Task statement (the rectangle task): ABCD is a rectangle, \overline{AB} has a length of 6.5 cm, \overline{BC} has a length of 4 cm. M is a point on segment \overline{AB} , N is a point on segment \overline{BC} , P is a point on segment \overline{CD} , and Q is a point on segment \overline{DA} . In addition we have that $\overline{AM} = \overline{BN} = \overline{CP} = \overline{DQ}$. Where should point M be located in order for the quadrilateral MNPQ to have the minimum area possible?

An Implementation Guide

A dynamic approach using the GeoGebra or Cabri-Geometry software

1. Read the task statement individually and discuss with your partner (pairs work) key information that helps you make sense of the task. Use a dynamic software to draw the given rectangle by using different commands (perpendicular, rotation, circle, etc.). Construct a dynamic model in which you can move point M along segment \overline{AB} to generate a family of inscribed quadrilaterals.
2. What properties do the inscribed quadrilaterals hold? Can point M be located on any point on segment \overline{AB} to draw the inscribed quadrilateral? Explain: what is the domain for M to always construct the quadrilateral?
3. Graph the area inscribed quadrilateral behavior by finding the locus of the point that relates the position of point M on \overline{AB} to the corresponding quadrilateral area? What properties does the graphic area representation have?
4. Identify visually at what point on the graph the quadrilateral area reaches its minimum value? Is there any pattern associated with the position of point M, the lengths of quadrilateral sides, and the minimum area? Draw a table showing some values of segment \overline{AM} and the corresponding quadrilateral area.

On the algebraic model

1. Is there any relationship between the area of the four triangles that appear in the corner of the figure (Figure 1), the area of the given rectangle and the area of the inscribed quadrilateral? Use a proper notation to identify the figures involved in the task representation.

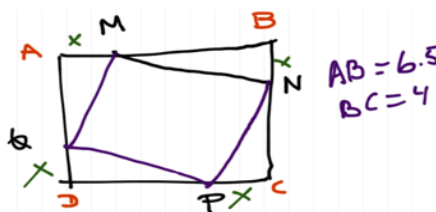

Figure 3. Scheme for the algebraic model.

2. Find an expression for the area of quadrilateral MNPQ. Graph this expression that represents the area of quadrilateral MNPQ and discuss what type of properties it has.
3. Find the position of point M for which the quadrilateral area reaches its minimum. Compare this value with that previously obtained through the use of the software.
4. Change the dimensions of the initial rectangle to sides a & b and find the general model that describe the inscribed quadrilateral area. What is the value of \overline{AM} for which the area of the inscribed quadrilateral gets its minimum value? What does that value tell you in terms of sides a & b of the rectangle?
5. Explore algebraically and dynamically a case in which the initial rectangle is changed to a *parallelogram*.

B. The participants and the tasks implementation. Nine prospective high school teachers worked on three hours weekly problem solving seminar during one semester. The seminar was part of master program to prepare high school teachers and involved both activities to extend their mathematical knowledge and to construct basis to teach

and to do research at the high school level. The participants' background included five majors in mathematics and four in engineering and had little experience in the use of technology. The task that we discussed in this report was given to the participants in the last week of the course. A mathematics educator and two doctoral students coordinated the development of each session.

In general terms, during the sessions the participants initially worked on each task individually and later in pairs, and some pairs' work was also presented and discussed within the whole group. In this report, we focus on presenting and discussing what participants exhibited while working on the Rectangle Task discussed previously. The analysis of the participants' cognitive behaviours was based on processing data that came from their computers' file sent after each session, individual interviews and class observations. It is important to mention that our initial unit of analysis was to focus on the participants' contribution as a whole or group; however, a close analysis of two cases (Anna and Daniel) was also included. In general terms, Anna and Daniel's problem solving behaviours provide robust information regarding difficulties associated with the appropriation process of the tool in one case (Anna) and a clear appropriation in another case (Daniel).

ANALYSIS OF THE PROBLEM SOLVING SESSIONS AND RESULTS

To present main results found in this study, we first identify main approaches exhibited by the participants following the main points addressed in the implementation guide. A summary of each participant contribution is shown in Table 1. Later, we focus on the work of two participants (Anna and Daniel) who were judged to be representative of the group approaches to the task. In some cases we added some comments to emphasize the participants' problem solving behaviours. All the participants were able to construct a dynamic model of the task. That is, they drew the rectangle using the compass (or circle) and polygon tools to set the corresponding dimensions. However, they showed differences in situating the mobile point that became the vertex that controls the inscribed quadrilateral. Table 1 shows main resources, strategies, and representations that the participants exhibited during the individual interaction with the task. We focus on the work of Anna and Daniel to address and analyse the group's problem solving behaviours.

The case of Anna. Anna drew segment \overline{AB} and adjusted its length to 6.5 cm, drew perpendicular lines to segment \overline{AB} from A and B to draw the rectangle. Then, she chose point M on side \overline{AB} and with the length of segment \overline{AM} as a radius, she drew circles with centres at B, C, and D. Points N, P, and Q are the vertices of the inscribed quadrilateral MNPQ (Figure 2). At this stage, she realized that when point M is moved to certain position the inscribed quadrilateral disappeared (when the length of segment \overline{AM} is longer than 4). Then, she concluded that the domain for moving M must be $[0, 4]$. However, she never redefined the initial domain for moving point M. She also observed that for different positions of point M the corresponding quadrilateral area changes as well.

Based on this information, Anna decided to represent the quadrilateral area variation graphically. To this end, she transferred via a circle the length \overline{AM} to the x-axis and drew a circle with centre the origin and radius the area value. Then, she drew a perpendicular to x-axis passing by the intersection point of the circle with radius the length of \overline{AM} and the x-axis. This perpendicular intersects the circle with radius the area value at K. With the software she traced the locus of point K when point M is moved along segment \overline{AB} (Figure 3). In her interpretation of the graph, she never explained why she ignored part of the generated locus to affirm that the vertex of the parabola was the position where the inscribed quadrilateral reached minimum value. That is, when length of segment \overline{AM} becomes 2.63 cm.

Table 1. Main resources, strategies, and representations exhibited by the participants.

Dynamic model construction	Mobile point M on segment \overline{AB}		Mobile point M on the rectangle border	Point M on a segment of length 4
	Daniel, Dalia, Nalleli, Oscar, Yanira		Anna, Cesar, Marco	Ruben
Graphic representation through the locus of a point	Use of circles to transfer lengths and perpendiculars.		Use point $(x(M), \text{area of } MNPQ)$	Transference measure command and perpendiculars
	Correct procedure	Incorrect		
	Dalia, Marco, Yanira	Anna, Cesar	Daniel, Oscar, Nalleli	Ruben
Use of Excel	Focusing on right triangles		Area of inscribed quadrilateral expressed algebraically	
	Daniel, Marco, Ruben, Anna (with a mistake)		Cesar, Dalia, Oscar, Nalleli, Yanira	
An algebraic approach	Focusing on the area of the four right triangles, maximum area		Representing the area of parallelogram MNPQ by subtracting the area of the four right triangles from the rectangle area (finding the minimum)	
	Daniel		Anna, Dalia, Cesar, Oscar, Marco, Nalleli, Ruben, Yanira.	

Comment: To some extent, Anna showed some level of appropriation of the software that led her to represent the task; however, she lacks sense-making behaviours to initially relate the domain for moving point M (which she found it correctly) to the construction of the inscribed quadrilateral. The part of the graph that she does not interpret is generated when M is moved along the border instead of focusing on the particular domain $[0, 4]$. Then, she made a **mistake** to associate point K (intersection of circle with radius the area of the inscribed quadrilateral) as a point that relates the position of point M and the corresponding area of the inscribed quadrilateral. It is clear that the use of the tool requires that learners become engaged in monitoring or metacognitive behaviours to constantly interpret what is observed numerically and graphically.

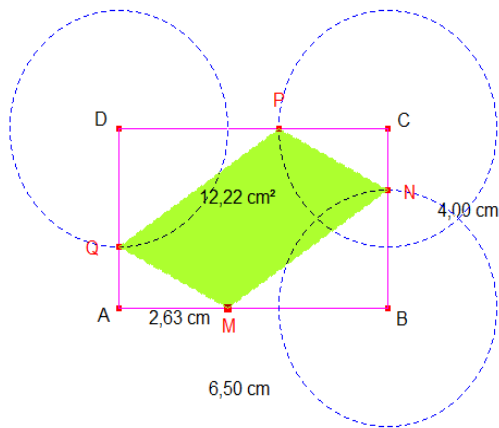

Figure 2. Drawing the rectangle and the inscribed quadrilateral.

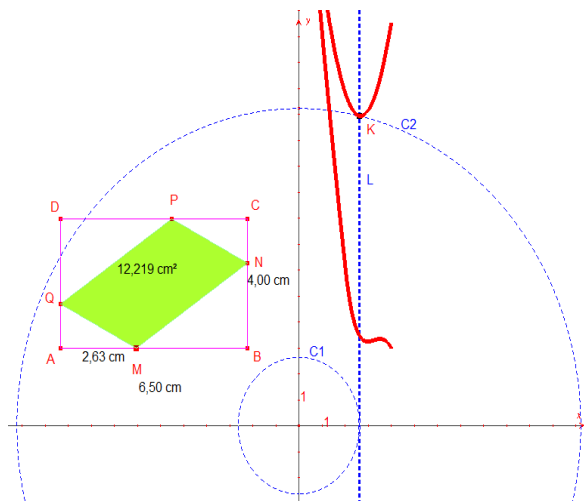

Figure 3. Representing the inscribed quadrilateral area variation graphically.

Anna also approached the problem with Excel by assigning some values to \overline{AM} and by finding the lengths of the hypotenuses of four right triangles formed at rectangle vertices. She found the area of the inscribed quadrilateral; however, she erroneously assumed that the quadrilateral was a rectangle (Figure 4). It seems that she visualized this figure in the representation she got through the software and never looked for its geometric properties. It is important to mention that Anna, in general terms, took important decisions based on what she thought the figures or graphs obtained through the use of the tools held; rather than reflecting on their actual mathematical properties. That is, the use of the tool provided her the means to affirm, for instance, that the inscribed quadrilateral in Figure 2 was a rectangle.

It is interesting to observe that when Anna approached the task algebraically, she relied on Figure 5 to correctly express the area of the inscribed quadrilateral in terms of the areas of the initial rectangle and the area of the four right triangles. That is, she expressed the area of the inscribed quadrilateral as: $A_{MNPQ} = A_{ABCD} - 2A_{QAM} - 2A_{MBN}$. This led her to write: $A_{MNPQ} = 26 - 2\left(\frac{x(4-x)}{2}\right) - 2\left(\frac{x(6.5-x)}{2}\right)$ and $A_{MNPQ} = 2x^2 - 10.5x + 26$. Then, she applied calculus procedures to get the minimum value of the function area. That is, she calculated $A'_{MNPQ} = 4x - 10.5$ and she solved the equation $0 = 4x - 10.5$ to get $x = \frac{10.5}{4} = \frac{21}{8}$ and $y = \frac{391}{32} \approx 12.21$. Similarly, she approached the general case for a, b the rectangle dimensions to obtain the area expression $A_{MNPQ} = 2x^2 - (a + b)x + ab$ and the value of $x = \frac{a+b}{4}$ in which the function gets its minimum value.

Comment: Anna's participation and ways she worked on previous sessions let us to observe that she was fluent in working with the algebraic model of the tasks; however, even in this domain she did not reflect on what the results she got meant. For example, she never graphed the algebraic model to identify the minimum point on the graph and

more importantly to make sense of her results by contrasting her results with what she had done with the use of the software and Excel. In terms of the tool appropriation, it is important to mention that Anna was able to use proper commands to dynamically represent the task; however, she did not reflect on the position of point M to always generate the inscribed quadrilateral. Neither she was able to realize that the point used to generate the area locus did not correspond to the area value associated with the position of point M. That is, in accordance to the conceptual framework, Anna needs to focus on the development of ways to monitor her work and to constantly make sense of results, obtained through the use of the software, in terms of analysing its mathematical properties and pertinence. For example, she was not interested in explaining why the graph representation of the area variation achieved through the software differs from that obtained through Excel.

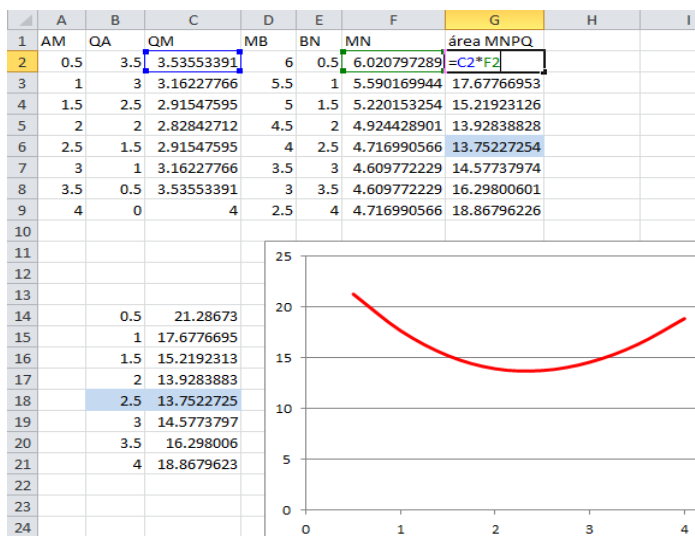

Figure 4. Approaching the problem with Excel.

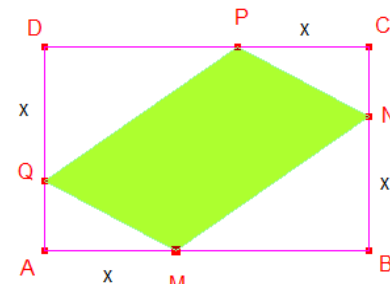

Figure 5. Scheme used for the algebraic approach.

The Case of Daniel. Daniel initially constructed the dynamic model (using GeoGebra software) of the task by selecting on the plane the four vertices of the rectangle. He did this by directly writing on the *input bar* the coordinates $D(0,0)$, $C(6.5,0)$, $B(6.5,4)$ y $A(0,4)$. Then, he chose point M on segment \overline{AB} and located the vertices M, N, P and Q of the inscribed quadrilateral. He transferred the length \overline{AM} to the other sides of the rectangle, and with the command Polygon, he drew the inscribed quadrilateral. He defined point E (in the *input bar*) as $(x(M), polygon2)$ which represents a point on the plane with coordinates the length of AM and its corresponding quadrilateral area. Then, he traced the locus of point E when point M is moved along segment \overline{AB} (Figure 6).

He reported that based on the graph of the function area there is a minimum value close to 2.6 with an area of 12.22 squared units. He identified and made explicit the segment that represent the domain for moving point M was $0 \leq x \leq 4$; and also provided an argument to affirm that the inscribed quadrilateral was a parallelogram. He also

constructed a table to explore the behaviour of the sum of areas of the right triangles formed at the rectangle vertices. Based on the table data, he identified the position of x where such sum of the areas reaches its maximum value (Figure 7). The last column of table also showed when the inscribed quadrilateral gets its minimum area.

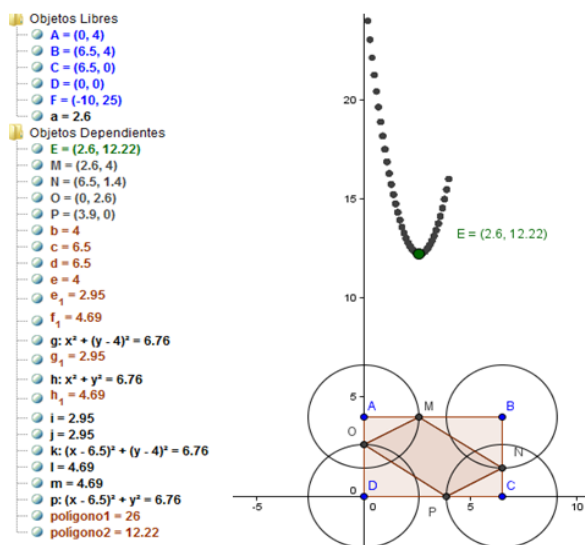

Figure 6. Daniel's dynamic model of the task.

x	Triángulos1	Triángulos2	Suma de Triángulos	Cuadrilátero
2.621	3.614359	10.166859	13.781218	=26-(B54+C54)
2.622	3.613116	10.168116	13.781232	12.218768
2.623	3.611871	10.169371	13.781242	12.218758
2.624	3.610624	10.170624	13.781248	12.218752
2.625	3.609375	10.171875	13.78125	12.21875
2.626	3.608124	10.173124	13.781248	12.218752
2.627	3.606871	10.174371	13.781242	12.218758
2.628	3.605616	10.175616	13.781232	12.218768
2.629	3.604359	10.176859	13.781218	12.218782

Figure 7. Approaching the problem with Excel (Daniel).

Daniel also approached the task algebraically in terms of finding where the area of the four right triangles formed on the rectangle got its maximum value. It is interesting to observe that Daniel focused his attention to finding the maximum area of the four right triangles rather than finding the minimum area of the inscribed quadrilateral. Both approaches are equivalent. To this end, he wrote: *Area of the triangles* = $2 \frac{x(6.5-x)}{2} + 2 \frac{x(4-x)}{2} = 6.5x - x^2 + 4x - x^2 = 10.5x - 2x^2$; then, he calculated the derivative of this expression $A'(x) = 10.5 - 4x$ and he solved $A'(x) = 0$ to get $x = 2.625$ as a critical point. Using the argument that $A''(2.625) < 0$, he concluded that the maximum value of the area function was at $(2.625, 13.78125)$. It is important to mention that Daniel graphed the algebraic model of the task and concluded that this graphic representation coincided with the one he obtained with the tool.

Similarly, he approached the case where the dimensions of the initial rectangle were a & b . Here, he found the area of the inscribed parallelogram by calculating the area of the rectangle (ab) and subtracting the area of the four right triangles, that is $A_p(x) = 2x^2 - (a + b)x + ab$. Then by using calculus procedures, he found the value x where this function reaches its minimum value $x = \frac{a+b}{4}$ whose area value is: $A_p\left(\frac{a+b}{4}\right) = \frac{6ab - (a^2 + b^2)}{8}$. He also explored the case where the initial figure was a parallelogram and with the software found that shown in Figure 8. Daniel showed several cognitive behaviours through the development of the sessions and a clear disposition to go beyond particular results.

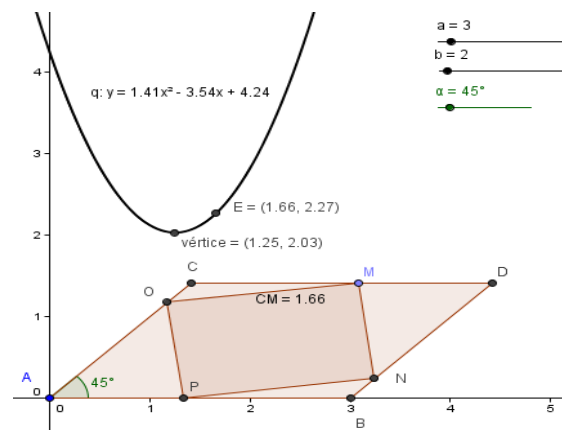

Figure 8. Case where the initial figure was a parallelogram.

Comment: Daniel’s approach to the task shows how the use of the tool becomes important to constantly analyse what is generated with the tool and the task conditions or statement. For example, focusing on the domain of the area function helped him generate the graphic representation of the area function within the context of the problem. Likewise, he shows an efficient use of the tools’ affordances to initially construct a point to generate the locus area and later to explore its behaviour through a table and algebraically. That is, he shows a robust and coordinated use of the tool to make sense of the tasks and to explain, contrast, and support results that emerge from dynamic, algebraic and empirical approaches to the task solution. In addition, the dynamic model of the tasks became for him an instrument to explore connections and general cases associated with the initial task.

DISCUSSION OF RESULTS

How can we interpret the participants’ work in terms of the reasoning and sense making conceptual framework sketched previously? Specifically, how did the finding or results of the study respond to initial research questions? It is observed that there appear differences in reasoning about the tasks when representing it dynamically and algebraically. Thus, reasoning with the tool involved focusing on ways to control the movement of a vertex of the inscribed quadrilateral to generate a family of them holding the required conditions. A key software affordance was *dragging* a point to generate a family of inscribed quadrilaterals. This let the participants to decide the *dragging domain* for the movable point and to analyse the interval in which the inscribed quadrilateral could be drawn. Then, the focus was on generating a graphic representation of the area variation of the family of inscribed quadrilaterals. This was achieved by relating the position of the moving point and the corresponding area of the inscribed quadrilaterals. That is, the area behaviour of this family of quadrilaterals was represented and explored geometrically without relying on the algebraic model.

At this stage, the participants thought of the problem in terms of the software affordances since they relied on measuring distance between a vertex and the movable point, area of the corresponding quadrilateral, and the locus command to generate the graphic representation of the inscribed quadrilaterals. To complement the software

approach to the task, some students relied on a table to record the area behaviour of the inscribed quadrilateral. On the other hand, the construction of an algebraic model demanded that initially the participants focused on ways to express the area of the inscribed quadrilateral. The algebraic model of the task led them to use calculus procedures to find the point where the model reached its minimum value. Based on this model, some of the participants sketched its corresponding graphic representation. In general terms, the construction of a dynamic model of the problem provided the participants an opportunity to initially visualize the behaviour of embedded objects without having the corresponding algebraic model.

Making sense of such objects behaviours requires paying attention to specific elements of the representation (domain of movable points, interpretation of the area graph, etc.) that later can be related to the algebraic model. That is, both approaches (software and paper and pencil) offered distinct opportunities for the participants to explore and interpret results.

Regarding the second research question, the cases of Anna and Daniel showed different level of the tool appropriation which is manifested through what sense they made of the achieved representations and exploration of the task and results. For example, Anna tended to focus her attention to the use of the software commands without examining or interpreting what she gets in terms of the task conditions. For example, she didn't even mention why the locus generated in Figure 3 included more elements than the graph of a parabola. She never questioned the domain for moving point M in her dynamic representation of the task. In general terms, she lacks resources to activate conceptual information to interpret and make sense of what she achieved through the software. That is, in order for her to efficiently use the software, she needed to constantly reflect on the extent to which the generated object was consistent with, for example, the results she got through the algebraic model.

On the other hand, Daniel seemed to constantly monitor not only the task representation he obtained through the tool, but also contrasted his results with the algebraic and Excel approaches. In addition, he shows a robust appropriation of the tool when he showed a coordinated used of the software affordance throughout the representation, exploration of the task including ways to extend the initial task.

The findings in this report provide useful information on how the learners' tool appropriation goes hand in hand with their interpretation of software outcomes and the analysis of the algebraic model of the tasks. Thus, prospective teachers need to direct their attention not only to different ways to construct dynamic representations of mathematical tasks; but also to the development strategies that help them monitor and analyse the consistency and pertinence of results.

CONCLUSIONS

The systematic use of a dynamic geometry environment provides an opportunity for prospective teachers to develop resources and strategies to construct dynamic

representations of the task. Thus, dragging objects within the model, measuring object attributes, and finding objects loci became crucial affordances to identify invariants or to analyse loci behaviours. The participants recognized that the graphic representation of the phenomenon achieved through the tool offers visual and empirical information that later can be contrasted with the analysis of the corresponding algebraic model. In addition, the diversity of approaches shown to construct a dynamic model became important to contrast different levels of appropriation of the tools. For example, using sliders to represent the quadrilateral sides or to use the side bar to construct a point on the plane that represents the position of the movable vertex offers clear advantages to explore other family of quadrilaterals. In conclusion, all the participants recognized that the use of the tool to represent and explore the task not only demands to think of the task in terms of the software affordances; but also complement the ways of reasoning involved in algebraic approaches.

ACKNOWLEDGEMENTS

This report is part of the activities associated with two research projects: Plan Nacional I+D+I del MCIN, Ref. EDU2011-29328 and Conacyt-Mexico, Reference 168543.

REFERENCES

- Dick, T. P. & Hollebrands, K. F. (2011). *Focus in high school mathematics: Technology to support reasoning and sense making*. Reston, VA: The NCTM.
- Hoyles, C. & Noss, R. (2008). Next steps in implementing Kaput's research program. *Educational Studies in Mathematics*, 68, 85-97.
- NCTM (2009). *Focus in high school mathematics reasoning and sense making*. Reston, VA: NCTM.
- Sacristán, A.I., Calder, N., Rojano, T., Santos-Trigo, M., Friedlander, A. & Meissner H. (2010). The Influence and Shaping of Digital Technologies on the Learning and Learning Trajectories of Mathematical Concepts. In C. Hoyles & J. Lagrange (Eds.), *Mathematics Education and Technology – Rethinking the Terrain: The 17th ICMI Study*, (pp. 179-226). NY: Springer.
- Santos-Trigo, M. & Camacho-Machin, M. (2009). Towards the construction of a framework to deal with routine problems to foster mathematical inquiry. *PRIMUS*, 19(3), 260-279.
- Schoenfeld, A. H. (2009). An essay review of the NCTM high school curriculum project. *Mathematics Teacher*, 103(3), 168-171.
- Trouche, L. (2004). Managing the complexity of human/machine interactions in computerized learning environments: Guiding students' command process through instrumental orchestrations. *International Journal of Computers for Mathematical Learning*, 9, 281–307.

THE ROLE OF USING TECHNOLOGY AND CREATIVITY IN DEVELOPING POSITIVE DISPOSITIONS TOWARD MATHEMATICAL PROBLEM SOLVING

Mehmet Türegün, Luis Conde

Barry University

mturegun@barry.edu, lconde@barry.us

In this paper the connections among technology, creativity, and attitudes towards mathematical problem solving are examined. The perceptions of a group of in-service teachers regarding a creative mathematical problem solving activity with a particular application to estimating the area of irregularly shaped polygons are investigated.

PURPOSE OF STUDY AND RESEARCH QUESTIONS

The purpose of this study was to examine the individual perceptions that in-service teachers have regarding the use of tangrams, geoboard and graph paper activities in teaching mathematical problem solving and geometry. In order to gain a broader and deeper insight into our research questions, we gathered and analyzed qualitative data including, but not limited to, teachers' reflective journal entries, questionnaires, and group discussions which took place during a semester-long graduate course focusing on early and middle school mathematical problem solving. The study aimed at answering the following research questions: What are the perceptions of in-service teachers' regarding the use of tangrams and geoboard activities in teaching mathematical problem solving and geometry? More specifically, this study addressed the following question: What role, if any, does creativity and use of technology play in developing positive dispositions toward mathematical problem solving?

BACKGROUND AND THEORETICAL FRAMEWORK

In order to investigate and establish the connections among creativity, technology, and mathematical problem solving, we start out by examining several goals delineated by the National Council of Teachers of Mathematics (NCTM), and the mathematical practice standards described by the Common Core State Standards (CCSS) for mathematics education. Helping students develop skills in using proper geometric and mathematical vocabulary, in orienting, recognizing and identifying various shapes, and in discovering relationships among the 2-dimensional geometric shapes is considered to be an important goal of teaching early childhood mathematics (NCTM, 2003).

The NCTM focal points based on various grade bands can be found at <http://standards.nctm.org/document/chapter5/index.htm> for grades 3-5, and <http://standards.nctm.org/document/chapter6/index.htm> for grades 6-8.

The CCSS mathematical practices are listed at <http://www.corestandards.org/Math/Practice>. The NCTM focal points and the CCSS include, but not limited to, fluency, flexibility, uniqueness, precision, persistence, recognition of patterns, structures and geometric shapes, intuition, and imagination. Our framework is based on the NCTM Standards for Mathematics Education, which has the following strands: Number and Operations, Algebra, Geometry, Measurement, Data Analysis and Probability, Problem Solving, Reasoning and Proof, Communication, and Connections and Representation. Although the particular strand addressed in this paper is Geometry, which provides a means for describing analyzing and understandings shapes and structures, there are several connections of Geometry to other strands, such as Numbers and Operations, Measurement, Problem Solving, and Communication.

The NCTM Standards for Mathematics Education do not list creativity explicitly as one of the strands of focus. Since the mid 1950s there has not been a unanimously agreed definition for creativity among the researchers in the field. However, the elements listed in the NCTM focal points and the CCSS are considered by many researchers as some of the fundamental components of creativity. As expected, intuition and imagination are intertwined with creativity. Imagination is especially powerful in solving problems involving shapes and forms. Even though teachers realize that creativity plays an important role in educating students, most teachers, over the years, have indicated to us that they need guidance and support in understanding how to systematically incorporate creativity into their mathematics classrooms and lesson plans.

Over the years the NCTM Standards have been a strong advocate for the use of technology in teaching mathematics. Technology, especially with the advent of various mobile device features and numerous apps, has become an indispensable part of our daily lives. Since most of the students in our classrooms today have used the internet, smart phones, and various forms of social media from early on in their lives, they tend to process information, solve problems, interact with their surroundings, and, in essence, learn quite differently (Prensky, 2001). In order to keep the interest and accommodate the needs of our “Digital Native” students, we, as educators, may need to change the way we used to teach, which, for the most part, is based on how we were taught in a slow, sequential, linear, algorithmic, and prescriptive fashion. Generally speaking, our educational system in the United States has a relatively slow pace of change. However, advances in technology have enabled many educators, even the ones considered by Prensky (2001) as “Digital Immigrants”, to at least attempt to model the use of technology as a problem solving tool by increasingly using dynamic, interactive, and visual simulation/applet activities as effective instructional tools to facilitate explorations of concepts in their classrooms at all grade levels. As observed by the authors, as well as indicated by many researchers, attempts made by in-service teachers, especially the ones at the initial career stages, to use technology as a problem solving tool are, for the most part, limited to be haphazard approaches. In-service

teachers are in need of guidelines for planning and implementing activities using various forms of technology in teaching mathematical topics and concepts.

In the next section, we describe, along with its historical background, a particular activity designed specifically with a focus on weaving a single curricular thread by using technology, infusing creativity and imparting positive dispositions toward mathematical problem solving among in-service teachers.

METHODOLOGY

A total of 13 in-service teachers, who were enrolled in a graduate level course focusing on early and middle school mathematical problem solving, participated in the study. The years of teaching experience for this group of 12 female and one male teacher ranged from three to 25 years at various grade levels from kindergarten to middle school grades. The ages of the group varied from 26 to 58 years. Although one or two of the teachers in the group were somewhat familiar with and have heard of tangrams, most of the teachers in the group had very little to no previous experience in incorporating tangrams into teaching mathematics and geometry in their respective classrooms.

The particular activity, in which we developed to engage this group of in-service teachers, was based on one of the oldest Chinese puzzles/games known. Tangrams, as they are known in the West, are still used today by adults, as well as children. In our efforts to establish the connections among creativity, technology, and mathematical problem solving, we deemed the choice of tangrams to be an appropriate fit for the creativity component of the activity. The word tangram may have come from the Tang Dynasty (AD 618-906), which is one of the ruling families whose rule spanned three centuries of Chinese history. It is regarded by the Chinese as one of their most glorious periods, when the country was a single unified empire. It was an era of cultural refinement, territorial expansion and great prosperity. The word gram indicates a drawn or written message. A tangram originates from a large square, typically a four-inch by four-inch one, which is dissected into seven pieces of only three distinct shapes in various sizes (Bohning & Althouse, 1997). The seven pieces consist of two small triangles, one medium triangle, two large triangles, one square, and one parallelogram. Each piece is called a *tan*. In creating a picture, a figure, or different shapes of humans and animals, all seven pieces must be used. The pieces must touch, but not overlap. In using a tangram activity, we aim to foster creativity in school mathematics with an emphasis on critical thinking, and ability to analyze and detect patterns. As we articulate in this paper, the use of tangrams also may allow teachers to explore ways in which students can be encouraged to re-invent or learn a theoretical result, or a theorem by way of discovery. Since one can arrange the seven pieces of the tangram in infinitely many different ways, the number of shapes one can create using the tangram is infinite. This particular feature of tangrams can provide an opportunity for educators to develop a creative activity for students in different levels of mathematics classes.

The medium triangle, the square, and the parallelogram are all twice the area of one of the small triangles. Each of the large triangles is four times the area of one of the small triangles. All the angles in these pieces are either right angles or angles of 45 or 135 degrees. All of the seven individual pieces of the tangram are convex polygons. However, one can easily use the seven pieces to create concave polygons with at least one angle being greater than a 180 degree angle. Although, as stated earlier, the number of different shapes that one can create by using the tangram is infinite, the number of convex polygons that one can create is only thirteen. In their paper, Wang and Hsiung (1942) provided an outline of a mathematical proof for this result, and listed all thirteen convex polygons.

According to the Chinese tradition, when tangrams are used in telling stories, the storyteller arranges the seven pieces to create the shapes of particular characters in the story. As new characters or figures emerge in the story, the seven pieces are rearranged to represent the new characters or figures, as demonstrated in *Grandfather Tang's Story* by Tompert (1990). The fox fairies in *Grandfather Tang's Story* are an integral part of Chinese folklore. They are believed to not only have magical or supernatural powers of transformations, but also to live for eight hundred to a thousand years (Tompert, 1990). The story is geared specially toward elementary school students. However, it can easily be modified to be used in middle school mathematics or geometry classes. Although the popularity of tangrams has never rivaled the popularity levels of other more established Chinese puzzles/games, such as checkers and tic-tac-toe, arranging the tans into letters, numbers, various shapes for different animals, humans, or other creatures and figures can be fun, thought provoking, and a creative activity for students in all grade levels, and people in all ages (Read, 1965). Since tangrams provide a concrete way to learn physical knowledge in order to understand geometric concepts, they are considered to be a very useful manipulative in teaching mathematics and geometry (Bohning & Althouse, 1997). Several researchers concluded that the use of tangrams as a teaching tool to inspire observation, imagination, creativity and logical thinking among school children was a worthwhile effort, as well as to help school children develop skills in using proper geometric and mathematical vocabulary, in orienting, recognizing and identifying various shapes, and in discovering relationships among the 2-dimensional geometric shapes (NCTM, 2003; Olkun, Altun, & Smith, 2005; Russell & Bologna, 1982).

For the infusion of technology into the activity, we considered many pieces of software and several applets. A wide variety of applets is available for the use of tangram puzzles. The two most commonly used such applets can be easily located at the following web sites: <http://www.nctm.org/standards/content.aspx?id=25008>, and <http://www.cs.grinnell.edu/~kuipers/statsgames/Tangrams/>. Taking into consideration a suggestion made by Chance & Rossman (2006) regarding the use of simulation activities, we decided to initially use a hands-on Geoboard model and graph paper for the tangram activity and directly involved in-service teachers in the process. Not only does the initial use of a hands-on, concrete Geoboard model provide participants and

students with an increased chance of ownership by allowing them to internalize the model, but it also lays a foundation for a better understanding of the process as we transition subsequently to using technology in the form of a Tangram applet. The ownership component plays an important role in teaching. When a student creates or helps create a task, or an activity, or a problem to be solved, the subsequent ownership component potentially may contribute to the students' intrinsic motivation. It is also important to note here that using hands-on models, such as the Geoboards and other concrete materials, help students, who are especially in the lower grade levels, improve their dexterity.

Similarly, several research studies have indicated that hands-on models and activities also provide best practices and learning experiences for students with learning disabilities. Through a Concrete-Representational-Abstract (CRA) instructional approach, students can experience the concrete stages of working with Tangrams. Learning Disabled (LD) students, who learn basic mathematical facts with the CRA instructional approach, show improvements in acquisition and retention of mathematical concepts (Miller & Mercer, 1993). CRA also supports conceptual understanding of underlying mathematical concepts before learning "rules," that is, moving from a model with concrete materials to an abstract representation. Even though the CRA approaches are geared toward LD students, they proved to be effective for non-LD students in helping them gain an understanding of the mathematical concepts/skills that they are in the process of learning. Teaching mathematics through the CRA sequence of instruction has abundant support for its effectiveness for students with LD (Harris, Miller & Mercer, 1995; Mercer, Jordan, & Miller, 1993; Mercer & Mercer, 1998; Peterson, Mercer, & O'Shea, 1988) as well as for non-LD students (Barrody, 1987; Kennedy & Tipps, 1998; Van DeWalle, 1994). When LD students are allowed to first develop a concrete understanding of a mathematical concept and skill, they are more likely to perform that mathematical skill and develop the conceptual understanding of the mathematical topic at the abstract level.

In light of recommendations to initially use a concrete model, a geoboard model along with graph paper was used as an aid in teaching basic geometric concepts and in developing conceptual understanding of area and perimeter, as well as improving communication skills, sharing ideas, and using mathematical vocabulary. Next, we would like to establish a connection between the Tangram puzzle and Geoboard model in order to combine the two together in creating one cohesive unit/activity to let in-service teachers discover Pick's Theorem. Georg Alexander Pick was born in 1859 in Vienna, and according to Grünbaum and Shepard (1993), died around 1943 in Theresienstadt. The theorem was first published in 1899, but according to Steinhaus (1999), was not brought to broad attention until 1969. The theorem yields a very simple, yet elegant, formula for the area of polygons without self-intersection. The theorem is applicable to polygons with vertices located at the nodes of a square grid or on a lattice, as in the case of a geoboard model. The nodes are spaced at a unit distance from their immediate neighbors in all four main directions, except the diagonals.

Although the resultant formula from Pick's Theorem does not require mathematical proficiency beyond the middle school grade levels, Pick's formula can be shown to be equivalent to the Euler's formula in complex analysis using trigonometric and exponential functions (Funkenbusch, 1974). The proof of the theorem is beyond the mathematical sophistication of early and middle school students. It is, therefore, more appropriate to lead the early and middle school students to discover the result of the theorem, rather than having them construct a proof of the theorem.

A statement of the Pick's Theorem can be given as follows. Let P be a lattice polygon. Assume that there are I(P) lattice points in the interior of the polygon P. Let B(P) be the number of lattice points on the boundary of the polygon P. Furthermore, let A(P) denote the area of the polygon P. Then, the area of the polygon P can be expressed by the following equation.

$$A(P) = I(P) + B(P)/2 - 1$$

The result can be verified by using a geoboard model or an Applet. For example, one can use an online variant of a geoboard applet located on the NCTM website at <http://www.nctm.org/standards/content.aspx?id=25008> to verify the above formula. Figure 1 renders a picture of Geoboards and Tangrams as they are superimposed over each other from the NCTM Geoboard applet at <http://www.nctm.org/standards/content.aspx?id=25008>.

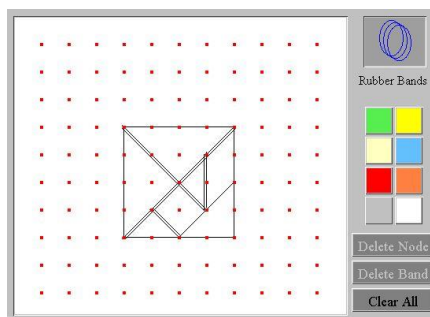

Figure 1. Creating polygons using the NCTM's Geoboard Applet.

Table 1 was constructed by using the NCTM Geoboard Applet in Figure 1, or using a concrete Geoboard model, with one square grid corresponding to an area of a unit square. The values given in Table 1 can be identified by examining Figure 1 for the triangles, square, and the parallelogram.

Table 1. The relationship among the number of interior points, boundary points, and the area.

Polygon P	I(P)	B(P)	B(P)/2	A(P)
Small Triangle	0	4	2	1
Medium Triangle	0	6	3	2
Large Triangle	1	8	4	4
Square	1	4	2	2
Parallelogram	0	6	3	2

Examining the examples used in constructing Table 1, one may observe certain patterns emerging. Once the relationships among the number of interior points, number of boundary points, the number of boundary points divided by two (if necessary), and the area are examined, the re-discovery of the formula resulting from Pick's Theorem can become possible. Depending on the level of students, helpful suggestions during the re-discovery process may include using Geoboard to create and explore all possible areas for polygons that contain only 3 boundary points. Then, one may want to start by investigating polygons that have 3 boundary points and no interior points, followed by 3 boundary points and 1 interior point, 3 boundary points and 2 interior points, and so on. Subsequently, one can move onto investigating polygons having 4, 5, and 6 boundary points in a similar fashion. Once the findings are organized in a table similar to Table 1, then, one may look for patterns in the table to help calculate the areas of other polygons. If students have trouble finding a formula that works for all polygons, the teacher may encourage them to consider the patterns formed by the data, and the types of numbers (i.e., integer, rational, etc.) that appear in the different columns of the tables created.

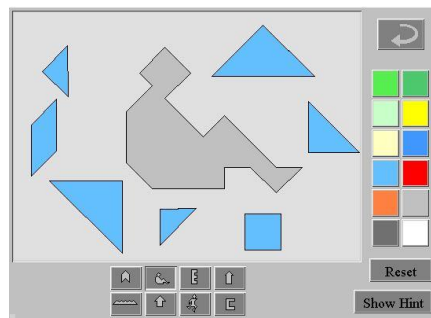

Figure 2. Creating figures or irregularly shaped polygons using the NCTM's Tangram Applet.

In order to foster creativity, teachers can ask students to arrange the tans into letters, numbers, human figures, shapes of different animals, and other creatures or figures of their own creations. Such a guided example is given in Figure 2. The application of Pick's Theorem to these different irregularly shaped polygons provides a means for students not only to verify the resultant formula further, but also encourages them to describe, analyze and understand shapes and structures, and allows an opportunity to make connections to other NCTM strands, such as Numbers and Operations, Measurement, Problem Solving, and Communication. Inspiring observation, encouraging fluency, flexibility, uniqueness, precision and persistence, developing ability to recognize patterns, structures and geometric shapes, and fostering intuition and imagination are also attended during the processes we described above. As an extension, one may obtain an estimate for the area of an irregularly shaped portion of a map by using Pick's Theorem. This extension initially involves drawing a grid on a transparent paper to scale, and then superimposing the grid over the map. One can

count the number of nodes inside and on the boundary of the map region, and then apply Pick's formula with the previously selected scale to obtain an estimate for the area. This particular application of Pick's Theorem to estimating irregularly shaped areas comes from a real word application used in the forest industry (Grünbaum & Shepard, 1993).

Based on the above described activities, we examined the in-service teachers' reactions, dispositions, and reflections regarding the creativity and the use of technology in teaching of mathematical problem solving and geometry. To be used as the sources of our data, in addition to the reflective journal entries, questionnaires, and group discussions, several open-ended response prompts were given to the in-service teachers for their written feedback on the above described activities. These open-ended response prompts included, but not limited to, the following questions: "What did you learn from the activities using Tangrams and Geoboards?"; "What was your experience like?" and "What were your thoughts after participating in the Tangram and Geoboard activities?" This particular study analyzed the responses of the in-service teachers, and the results are reported in the next section. Techniques such as triangulation of a variety of data sources were employed in order to ensure and increase validity of the interpretation of the data. A form of simultaneous triangulation was achieved by using in class group discussions, feedback from collaborative activities, weekly journals of in-service teachers, and my own reflective journal (Murphy, 1989). These items were regular components of the course assessment and used to solicit in-service teachers' thoughts, understandings, and experiences in various ideas, topics, and activities including, but not limited to, mathematical problem solving, discussed and used throughout the course.

The analysis of qualitative data involved an ongoing, iterative process of constant comparison of data with an open coding technique as suggested by Glaser & Strauss (1967). This ongoing process of data analysis and emerging theme searching is nicely aligned with the reflection-action-reflection cycle, which is inherent in teacher education, and an important element of being a reflective practitioner, as described by Schön (1983). Initially a number of different categories of responses were assigned for the data generated from different data sources. Based on further analysis, common characteristics among categories were identified resulting in a consolidation of categories into fewer and more general categories of responses.

RESULTS

As a result of the analysis described above, several emergent categories, such as developing positive dispositions toward geometry and mathematical problem solving, cognitive dissonance, collaborative learning, and adaptability for different grade levels were identified. For example, the following comments by one of the in-service teachers indicated a typical observation of the positive dispositions developed by using the activity:

I found the experience very rewarding. We were motivated to keep going and challenge ourselves to complete complicated tangram shapes. Overall, I learned a tremendous amount in our last class. The most important thing I learned was that we can motivate our students in math by using manipulatives and activities like these. They promote critical thinking, motivate our students, and foster creativity in math.

The above comments of this particular in-service teacher also reflected the fact that these activities were useful in fostering creativity in teaching of mathematics, as well motivating students.

Additionally, many in-service teachers realized the potential for interdisciplinary connections which can be explored, and subsequently established for their students. One of the in-service teachers stated:

Tangrams are great manipulatives and have multiple purposes that can be used in all subject areas to create literary images. In Language Arts it can be used to create characters of a story and also to create scenes as well. They can be used in mathematics to depict geometry, calculate angles, fraction concepts, calculate area, perimeter, spatial awareness, construct polygons, and used to solve mathematical problems.

Most of the in-service teachers found the activities to be quite challenging and difficult. We, as educators, need to be aware of how much cognitive dissonance an individual student can withstand before disequilibrium becomes, as Dewey (1938) put it, a miseducative experience to eventually bring the educational process and development of students to a halt. We need to be attentive to establishing this delicate balance between dissonance and perseverance. The cognitive dissonance experienced by many in-service teachers was articulated often. For instance, one of the in-service teachers commented as follows:

I learned a lot from doing the tangram activity. I learned about problem solving and perseverance. I wanted to quit so many times. It was frustrating and it took a lot of brain power to solve it. My experience during the tangram activity was challenging yet helpful. I am usually good at puzzles so I thought that it would be easy but it turned out to be hard. My experience during geoboard activity was actually very enjoyable. This was very difficult for me to wrap my head around. It was truly a battle of perseverance.

The socially constructed and negotiated meaning via group activities was another emergent theme. The comments similar to the following were widespread:

I enjoyed trying to come up with the area vs. perimeter formula. While I was working with my partner I was able to eliminate operations that would not work, without testing. We bounced ideas off one another and hypothesized.

The comments regarding collaborative learning, as well as the following comments, reflected the value of engaging students and active learning approach, as opposed to a lecture-and-listen format.

The Tangrams, is an amusing activity. This activity will keep students engaged as well as intrigued as to how rubber bands could make pictures.

Many in-service teachers recognized the suitability and adaptability of these activities for different grade levels. For example, the following comments by one of the in-service teachers indicated such a typical observation:

The tangram and geoboard activities provided me with valuable insight on how I could tailor activities to suit my mathematical learners on all levels. I discovered that I can create activities that span the elementary classroom to that of college levels.

Another in-service teacher shared a similar sentiment and made the following comments regarding modifying the activities to make them kindergarten friendly.

In addition to the figures, I learned mathematical equations that were useful to me. This activity was more exciting to me and it is something I would introduce to my kindergarten class. I would have to redirect the mathematical equations to make them kindergarten friendly and appropriate for the grade level. In order to do that I would ask, “How many pegs are touching the rubber band?”, “How many pegs are inside of the figure that are untouched?”, “How many pegs are in total on the board?”, and “How many pegs are on the board that were not used?” These questions can be used for counting in sequence, addition and subtraction.

One of the kindergarten teachers made the following comments on using these activities to help kindergarten students recognize and identify different shapes, number of sides and vertices of two-dimensional objects:

I can incorporate the use of geoboards to teach shapes in my classroom. Students would be able to create the shapes with the use of the board and rubber bands. Students could also identify how many sides and corners shapes have.

In general, the results of the data analysis indicated that this group of in-service teachers recognized and appreciated the connections between fostering creativity and infusing technology in their classrooms in order to help students develop positive dispositions toward mathematical problem solving.

CONCLUSIONS

This study investigated the connections among technology, creativity, and attitudes toward mathematical problem solving. The perceptions and reflections of a group of in-service teachers regarding a creative mathematical problem solving activity with a particular application to estimating the areas of irregularly shaped polygons were examined. Although the conclusions from the study are based on a single, small group of in-service teachers, the study revealed some possible common preconceptions which should be examined closely and taken into consideration in order to promote creativity in mathematical problem solving.

Aligned with the Five Core Propositions from National Board for Professional Teaching Standards from their website at <http://www.nbpts.org/five-core-propositions>, this particular group of in-service teachers was committed to think systematically about their practice and learn from experience to improve and enhance the way they teach.

As members of learning communities, in-service teachers showed a great interest in taking these activities back to their classrooms to their students, as well as to their fellow teachers and colleagues. As a sequel to this paper, we plan to develop a manuscript describing the implementation of these activities by this group of in-service teachers in their respective classrooms.

The processes described in this study encourages teachers and students to describe, analyze and understand shapes and structures, and allows an opportunity to make connections to NCTM strands, such as Numbers and Operations, Measurement, Problem Solving, and Communication. Inspiring observation, encouraging fluency, flexibility, uniqueness, precision and persistence, developing ability to recognize patterns, structures and geometric shapes, and fostering intuition and imagination are also attended during the processes we described above.

In general, the results of the analysis of responses produced supporting evidence for the need to provide environments rich in opportunities for in-service teachers to engage in creative activities in mathematical problem solving. Teaching methodologies more open to creative problem solving and supporting student construction of knowledge should be used in teaching of mathematics.

REFERENCES

- Baroody, A. (1997). *Children's mathematical thinking*. New York: Teachers College Press.
- Bohning, G., & Althouse, J. K. (1997). Using tangrams to teach geometry to young children. *Early Childhood Education Journal*, 24(4), 239-242.
- Chance B. L., & Rossman, A. J. (2006). Using simulation to teach and learn statistics. Paper presented at the 7th International Conference on Teaching Statistics (ICOTS-7), Salvador, Bahai, Brazil. Retrieved from http://www.stat.auckland.ac.nz/~iase/serj/publications/17/7E1_CHAN.pdf.
- Dewey, J. (1938). *Experience and education*. New York: Teachers College Press.
- Funkenbusch, W. W. (1974). From Euler's Formula to Pick's Formula Using an Edge Theorem. *The American Mathematical Monthly*, 81, 647-648.
- Glaser, B. G., & Strauss, A. L. (1967). *The discovery of grounded theory: Strategies for qualitative research*. New York: Aldine De Gruyter.
- Grünbaum, B. & Shepard, G. C. (1993). "Pick's Theorem". *The American Mathematical Monthly*, 100, 150-161.
- Harris, C. A., Miller, S. P., & Mercer, C.D. (1995). Teaching initial multiplication skills to students with disabilities in general education classrooms. *Learning Disabilities Research & Practice*, 10, 180-195
- Kennedy, L. M., & Tipps, S. (1998). *Guiding children's learning of mathematics*. Belmont, CA: Wadsworth.

- Mercer, C. D., & Mercer, A.R. (1993). *Teaching students with learning problems*. Upper NY, NY: Macmillan Publishing Co.
- Mercer, C. D., Jordan, L., & Miller, S.P. (1994). Implications of constructivism for teaching math to students with moderate to mild disabilities. *Journal of Special Education, 28*, 290-306.
- Mercer, C.D., Jordan, L., & Miller, S.P. (1996). Constructivism math instruction for diverse learners. *Learning Disabilities Research and Practice, 11*, 147-156.
- Muller, S.P., & Mercer, C.D. (1993). Using data to learn about concrete-semi-concrete-abstract instruction for students with math disabilities. *Learning Disabilities Research and Practice, 8*, 89-96.
- Murphy, S. A. (1989). Multiple triangulation: Applications in a program of nursing research. *Nursing Research, 38*(5), 294-297.
- NCTM. (2003). Developing Geometry-Understandings and Spatial Skills through Puzzlelike Problems with Tangrams. 4.4.2 Tangram Challenges. Retrieved from <http://www.nctm.org/standards/content.aspx?id=25015>.
- Olkun, S., Altun, A., and Smith, G. (2005). Computers and 2D geometric learning of Turkish fourth and fifth graders. *British Journal of Educational Technology, 36*(2), 317-326.
- Peterson, S. K., Mercer, C. D., & O'Shea, L. (1988). Teaching learning disabled students place value using the concrete to abstract sequence. *Learning Disabilities Research, 4*, 52-56.
- Prensky, M. (2001). "Digital Natives, Digital Immigrants Part 1". *On the Horizon, 9*(5), 1-6.
- Read, R. C. (1965). *Tangrams 330 Puzzles*. New York, NY: Dover Publications, Inc.
- Russell, D.S., & Bologna, E.M. (1982). Teaching Geometry with Tangrams. *Arithmetic Teacher, 30*(2), 34-38.
- Tompert, A. (1990). *Grandfather Tang's Story*. New York, NY: Crown Publishers, Inc.
- Schön, D. A. (1983). *The reflective practitioner: How professionals think in action*. New York, NY: Basic Books.
- Steinhaus, H. (1999). *Mathematical Snapshots*. New York, NY: Dover Publications, Inc.
- Wang, F. T., & Hsiung, C. (1942). "A Theorem on the Tangram". *American Mathematical Monthly, 49*(9), 596-599.

HOW TO FOSTER CREATIVITY IN PROBLEM POSING AND PROBLEM SOLVING ACTIVITIES

Cinzia Bonotto*, Lisa Dal Santo**

* Department of Mathematics, University of Padova

** Istituto Comprensivo G. Ciscato, Malo (VI)

bonotto@math.unipd.it, lisads7@gmail.com

The exploratory study presented here begins to investigate the relationship between problem-posing activities, supported by problem-solving activities, and creativity, when problem-posing process is implemented in meaningful situations involving the use of suitable real-life artifacts. The study is part of an ongoing research project based on teaching experiments consisting of a series of classroom activities in primary school, using suitable artifacts and interactive teaching methods in order to create a substantially modified teaching/learning environment. The focus is on fostering a mindful approach toward realistic mathematical modelling and problem solving, as well as a problem-posing attitude.

INTRODUCTION

In mathematics education, after over a decade of studies which have focused on problem solving, researchers have slowly begun to realize that developing the ability to pose mathematics problems is at least as important, educationally, as developing the ability to solve them (Stoyanova & Ellerton, 1996).

Problem formulating should be viewed not only as a *goal* of instruction but also as a *means* of instruction. The experience of discovering and creating one's own mathematics problems ought to be part of every student's education. Instead, it is an experience few students have today – perhaps only if they are candidates for advanced degrees in mathematics (Kilpatrick, 1987, p.123).

The most frequently cited motivation for curricular and instructional interest in problem posing is its perceived potential value in assisting students to become better problem solvers. To explore the potential value of problem posing in assisting students to become better problem solvers, several studies have been set up to investigate the relationship between solving word problems and posing word problems (e.g., Cai & Hwang, 2002; Ellerton, 1986; Silver & Cai, 1996). In these studies students were typically asked to generate one or more problems (sometimes of different levels of difficulty) starting from a given situational description, a picture, or a number sentence, and, afterwards, the quality of the mathematical problems generated by the students was compared with their problem-solving capacities (Verschaffel et al., 2009).

Besides ascertaining studies revealing the existence of a relationship between problem posing and solving, some design experiments have been realised wherein new

instructional approaches have been designed, implemented, and evaluated, in which problem posing is incorporated into the mathematics curriculum and used as a vehicle to improve students' problem-solving ability (English, 1998; Verschaffel et al., 2000). In general, these latter studies revealed that having students engage in some activities related to problem posing (e.g., making up word problems according to mathematical stories) may have a positive influence not only on their word problem-posing abilities but also on their problem solving skills and their attitudes towards mathematical problem solving and mathematics in general (Verschaffel et al, 2009).

From the studies on problem posing, we can conclude that this activity has a potential value in assessing and improving children's problem-solving capacities. However, an important feature of the problem-posing research up to now is that it has investigated the relationship between problem posing and solving especially, and even almost exclusively, for standard word problems that can be unproblematically modelled by one or more operations with the numbers given in the problem statement (Verschaffel et al., 2009, p.149).

Stated differently, no research investigated this relationship for problematic situations, wherein students have to use their commonsense knowledge and real-world experience when trying to model and solve the problem (Verschaffel et al, 2000). Furthermore, problem posing is a form of creative activity that can operate within tasks involving structured "rich situations" in the Freudenthal sense (1991), including situations involving real-life artifacts and human interactions. However, also the nature of this relationship still remains unclear.

For the previous reasons, the exploratory study presented here begins to investigate the relationship between *problem-posing* activities, supported by *problem-solving activities*, and *creativity*, when problem-posing process is implemented in situations involving the use of real-life artifacts, with their embedded mathematics. The study is part of an ongoing research project based on teaching experiments consisting of a series of classroom activities in upper elementary school, using suitable artifacts (Saxe, 1991) and interactive teaching methods in order to create a substantially modified teaching/learning environment. The focus is on fostering a mindful approach toward realistic mathematical modelling and problem solving, as well as a problem-posing attitude (Bonotto, 2009). The project aimed at showing how an extensive use of cultural or social artifacts and interactive teaching methods could be useful instruments in creating a new dialectic between school mathematics and the real world, by bringing students' everyday-life experiences and informal reasoning into play.

THEORETICAL FRAMEWORK

Problem posing has been defined by researchers from different perspectives (Silver & Cai, 1996). The term problem posing has been used to refer both to the generation of new problems and to the reformulation of given problems (e.g. Dunker, 1945; Silver, 1994). Silver (1994) classified problem posing according to whether it takes place before (pre-solution), during (within-solution) or after (post-solution). In particular, the process of problem posing can be considered as a problem-solving process in which

the solution is ill defined, since there are many problems that could be posed (Silver, 1995).

In this paper we shall consider mathematical problem posing as the process by which, on the basis of mathematical experience, students construct personal interpretations of concrete situations and formulate them as meaningful mathematical problems (Stoyanova & Ellerton, 1996). This process is favoured if suitable social or cultural artifacts are used in classroom activities. Problem posing, therefore, becomes an opportunity for interpretation and critical analysis of reality since: i) the students have to discern significant data from non significant data; ii) they must discover the relations between the data; iii) they must decide whether the information in their possession is sufficient to solve the problem; and iv) they have to investigate if the numerical data involved are numerically and/or contextually coherent. These activities, quite absent from today's Italian school context, are typical also of mathematical modelling processes and can help students to prepare to cope with natural situations they will have to face out of school (Bonotto, 2009).

Furthermore, there is a certain degree of agreement in recommending problem-posing and problem-solving activities to promote creative thinking in the students and assess it. Silver and other authors (Cai & Hwang, 2002; Silver, 1994; Silver & Cai, 2005; Yuan & Sriraman, 2010; Kontorovich et al., 2011) have linked problem posing skills with creativity, citing flexibility, fluency, and originality as creativity categories. In particular, Silver argued that creativity lies in the interplay between problem posing and problem solving:

It is in this interplay of formulating, attempting to solve, reformulating, and eventually solving a problem that one sees creative activity. Both the process and the products of this activity can be evaluated in order to determine the extent to which creativity is evident. Among the features of this activity that one might examine [could be] the novelty of the problem formulation or the problem solution [...] (Silver, 1997).

Creativity has received much attention in the literature, particularly in relation to distinctions between two types of thought: productive (divergent thinking) and reproductive (convergent) thinking (Guilford, 1950). One of the main lines of research on creativity concerns exactly the distinction between these two types of thought. First, Guilford dealt with creativity and noted that IQ and creativity could not be overlapped. He therefore hypothesized that a person could be creative without exceptional intelligence and vice versa. Thus, creativity began to be recognized as an asset, even if present in different degrees and shapes, of each person. Guilford saw creative thinking as clearly involving what he categorized as divergent production. He broke down it into nine skills: sensitivity to problems, ideational fluency, flexibility of set, originality, the ability to synthesize, analytical skills, the ability to reorganize, span of ideational structure, and evaluating ability. All these skills influence each other and represent the related aspects of a dynamic and unified cognitive system. The main models that describe the mathematical creative process emphasize the importance of sensitivity to the problems (problem finding) and their resolution (problem solving). Problem

finding, in particular, may be associated with mathematical problem posing. Problem-posing and problem-solving activities are therefore used by several authors to promote and evaluate creativity (Leung, 1997; Silver, 1997; Silver & Cai, 2005; Siswono, 2010; Sriraman, 2009; Torrance, 1966; Yuan & Sriraman, 2010).

Silver (1997) argued that inquiry-oriented mathematics instruction, which includes problem-solving and problem-posing tasks and activities, could assist students to develop more creative approaches to mathematics. It is claimed that through the use of such tasks teachers can increase their students' capacity with respect to the core dimensions of creativity, namely, fluency, flexibility, and originality. In a recent study, Kontorovich, Koichu, Leikin, and Berman (2011) used these parameters as indicators of creativity in students' problem posing. Moreover, the authors suggest that students' considerations of aptness, implied in the problem posing process, could serve as an other useful indicator of their creativity.

We believe that the creative process in mathematics may be encouraged by the presence of particular situations, for example of semi-structured type. Semi-structured problem-posing situations refer to ones in which students are provided with an open situation and are invited to explore the structure of that situation and to complete it by using knowledge, skills, concepts and relationships from their previous mathematical experiences (Stoyanova & Ellerton, 1996). The use of appropriate real life artifacts can help realize these situations that can become also "rich contexts" in the Freudenthal sense (1991). These artifacts, with their incorporated mathematics, can play a fundamental role in bringing students' out-of-school reasoning experiences into play, by creating a new tension between school mathematics and everyday-life knowledge (Bonotto, 2009).

The artifacts we introduced into classroom activities, for example supermarket bills, bottle and can labels, a weekly TV guide, the weather forecast from a newspaper, some menus of restaurants and pizzerias (see e.g. Bonotto 2005 and 2009), are materials, real or reproduced, which children typically meet in real-life situations. In this way we can offer the opportunity of making connections between the mathematics incorporated in real-life situations and school mathematics, which although closely related, are governed by different laws and principles. These artifacts are relevant and meaningful to children because they are part of their real life experience, offering significant references to concrete, or more concrete, situations. In this way we can enable children to keep their reasoning processes meaningful and to monitor their inferences (Bonotto, 2009). These artifacts may contain different codes, percentages, numerical expressions, and different quantities with their related units of measure, and hence are connected with other mathematical concepts and also other disciplines (chemistry, biology, geography, astronomy, etc.). It could be said that the artifacts are related to mathematics (and other disciplines) as far as one is able to find these relationships. From our experience, children confronted with this kind of activity also show flexibility and creativity in their reasoning processes by exploring, comparing, and selecting among different strategies. These strategies are often sensitive to the context

and number quantities involved and closer to the procedures emerging from out-of-school mathematics practice (Bonotto, 2005). We believe that immersing students in situations which can be related to their own direct experience, and are more consistent with a sense-making disposition, allows them to deepen and broaden their understanding of the scope and usefulness of mathematics as well as learning ways of thinking mathematically that are supported by mathematizing situations (Bonotto, 2009). Furthermore, by asking children to select other cultural artifacts from their everyday life, to identify the embedded mathematical facts, to look for analogies and differences (e.g., different number representations), to generate problems (e.g., discover relationships between quantities), we can encourage children to recognize a great variety of situations as mathematical situations, or more precisely as mathematizable situations, since a great deal of mathematics is embedded in everyday life.

Besides the use of suitable artifacts the teaching/learning environment designed and implemented in this study and present in other studies we have conducted (e.g. Bonotto, 2005 and 2009), is characterized by (i) the application of a variety of complementary, integrated and interactive instructional techniques (involving children's own written descriptions of the methods they use, in pair work, whole-class discussion, and the drafting of a text by the whole class), and (ii) an attempt to establish a new classroom culture also through new socio-mathematical norms, in the sense of Yackel and Cobb (1996).

THE STUDY

The overall aim of this exploratory study was to examine the relationship between *problem-posing* and *problem-solving* activities and *creativity*, when problem-posing process is implemented in situations involving the use of real-life artifacts, with their embedded mathematics. In this study, Guilford's characterization of creativity has been adopted.

In particular the study sought to investigate:

- the role of suitable artifacts as sources of stimulation for the problem posing process in semi-structured situations,
- the primary school students' capacity to create and deal with mathematical problems (including open-ended problems),
- the potential that the problem posing activity has for identifying and stimulating creative thinking in mathematics,
- the potential that the problem solving activity has for fostering a reflection on a previous problem posing activity and on the nature of problems created by students themselves,
- the primary school students' capacity to solve mathematical problems, to discuss their structure and to describe the reasoning behind the solutions they offered,

- a method for analyzing the products of problem posing that the teacher could use in the classroom to identify and assess both the activity of problem posing itself and the creativity of the students.

This exploratory study involved four fifth-grade classes (10-11 years old) from two primary schools in northern Italy, for a total of 71 pupils. The study was carried out by Lisa Dal Santo in the presence of the official logic-mathematics teacher. The first primary school was located in an urban area situated within a few miles of the centre of a city. The children were already familiar with activities using cultural artifacts, group work and discussions. The second primary school was located in a mountainous area. The children were not already familiar with these types of activities, even though the teacher had once proposed a problem-posing activity where the situation was a drawing of the prices of different products in a shop. The average marks in mathematics of the students were classified into three categories: high, medium, and low. On the basis of this classification the two schools were not uniform; in particular, the average marks in mathematics of the second school's pupils were mainly medium-high while the average marks obtained by pupils from the other school were medium-low.

The artifact used was the page of a brochure containing: the special rates for groups visiting the Italian amusement park "Mirabilandia", the menu and discounts applied, the cost for access to the beach, etc. This artifact was chosen considering that all students were already familiar with an amusement park because they had been to one. This page was full of information, including prices (some expressed by decimal numbers), percentages, and constraints on eligibility for the various offers. We wanted to motivate students by offering them a semi-structured situation as rich and contextualized as possible in order to permit them to use their extra-scholastic experience in the creation and resolution of problems.

TEACHING EXPERIMENT

The experiment consisted of three phases: (1) the presentation of the artifact used; (2) a problem-posing activity; (3) a problem-solving activity. The activities took place in three different days, a few days apart. The students worked individually for part (2); for part (3) they at first were divided in couples or in groups of three students and then participated in a collective discussion. Students could use the artifact and its summary during all three activities.

The first phase, of about two hours, consisted in the analysis and synthesis of the artifact. This phase was preparatory to the problem-posing activity. After presenting the whole brochure, a copy of one of the pages was given to each student and then he/she was invited to write down everything they could see on that page. Following that, there was a discussion on the observations: the aim was to verify students' understanding of the artifact and to create a summary of the mathematical concepts involved.

The second phase, lasting about an hour, consisted of an individual problem-posing activity in which the children had to create the greatest number of solvable mathematics problems (in a maximum time of 45-50 minutes), preferably of various degrees of difficulty, to bring to their partners in the other classroom. The children were not informed of the time limit in order to avoid them from experiencing anxiety. Rather, they were told that they would have plenty of time to do this activity and that problems would be collected when the majority of the students had finished. To allow for the pupils' self-assessment, they were given a sheet of paper for their calculations and solutions to the problems they had invented. Then, four problems for the next problem-solving activity were selected from among all the problems that had been created. In every class the problems chosen were problems with insufficient data, problems with an incorrect data or articulated problems in order to favor a discussion amongst the students.

The third phase, lasting about two hours, consisted of a problem-solving activity by students and ended with a collective discussion. The students were asked to solve problems, to write the procedure that they had used and to write considerations on the problem itself. Different problem solutions and ideas about problems structure that emerged during the discussion were compared and, at the end of the activity, a collective text summarizing the students' conclusions was written. So at this phase, a reflection on the previous problem posing activity and on the nature of problems invented was favoured by problem solving activity.

METHODOLOGY AND DATA ANALYSIS

Data from the teaching experiment included the students' written work, fields' notes of classroom observations and audio recordings of the collective discussions. All of the problems created by the students were analyzed with respect to their quantity and quality. To analyze the type of problems invented we followed the methodology proposed by Leung and Silver (1997); as regards to the analysis of the text of the problems we referred to the research of Silver and Cai (1996) and Yuan and Sriraman (2010).

The plausible mathematical problems (in the sense that they can apparently be solved, with no discrepant information, and with respect the conditions in the artifact) with sufficient data were analyzed with respect to their complexity, and were assessed from two perspectives: the first assessed the complexity of the solution and the second assessed the complexity of the text of the problem. With regard to the complexity of the solution, these mathematical problems were divided into multi-step, one-step and zero-step problems. With regard to the complexity of the text of the problems, plausible mathematical problems with sufficient data were divided into problems with a question and problems with more than one question. The latter, were divided in concatenated questions and non-concatenated questions. Furthermore, only the plausible mathematical problems with sufficient data were re-analyzed, this time, to evaluate their creativity. The criteria used to classify them were: the number and type of details

extrapolated from the artifact, the type of questions posed, and the added data included by the students.

To evaluate their creativity in mathematics, three categories were taken into consideration—fluency, flexibility, and originality—as proposed by Guilford to define creativity, and as used in the tests by Torrance and in other studies such as that by Kontorovich, Koichu, Leikin, and Berman (2011).

When considering the fluency of a problem, the total number of problems invented by the pupils of each school in a given time period, as well as the average number of problems created by each student, were taken into account.

Flexibility, instead, refers to the number of different and pertinent ideas created in a given time period. In order to evaluate the flexibility of the students, the mathematical problems were categorized considering both the number of details present in the brochure (e.g., entrance fee, price of lunch, etc.) which were incorporated into the text of the problem posed, and the additional data introduced by the students (e.g., calculating the change due after a payment). Once the problems had been categorized in the above way, the various types of problems that occurred in each class were counted.

The originality of the mathematical problems created by the students took into consideration the rareness of the problem compared to the others posed in each school. In order to evaluate the originality of a problem, it was considered original if it was posed by less than 10% of the pupils in each school (Yuan and Sriraman, 2010).

SOME RESULTS AND COMMENTS

A total of 63 students in both schools participated in the problem-posing phase and they created a total of 189 problems. Students from the first school invented 58 problems (57 were mathematical problems), while students from the second school invented 131 (all mathematical problems).

More than half of the problems that were invented by the students are solvable mathematical problems (64% of the problems created by the pupils of the first school and 60% of those created by the pupils of the second school). Table 1 shows the main quantitative results of both schools:

Table 1. The main quantitative results of both schools.

Category	First School	Second School
Non mathematical problem	1,72 %	0%
Implausible mathematical problem	18,97 %	29%
Plausible mathematical problem with insufficient data	8,62 %	10,69%
Plausible mathematical problem with sufficient data	63,79 %	60, 31%

Most of the problems created were similar to the standard ones used in schools, although there were some cases of creative and open-ended problems.

Then, analyzing these solvable mathematical problems we have found that i) the 81% of the first school and the 75% of the second school are multi-step problems; ii) the 78% of the first school and the 73% of the second school are problems with a question. Regarding problems with more than one question, in the first school the 62% have concatenated questions, and about 43% in the second school.

As far as creativity is concerned, the second school was more successful in all three categories used to assess performance (fluency, flexibility and originality). With regard to fluency, each student in the first school invented 2 problems on average, while each pupil of the second school invented 3 problems on average. With regard to flexibility, the problems created by the classes of the first school were divided into 11 categories, those of the second school into 16 categories. In evaluating originality, it was found that 3 original problems were created in the first school and 10 in the second school. Original problems include inverse problems, and problems containing almost all the information of the artifact.

It was thus found that the students of the second school demonstrated better performance on the suggested problem-posing task, in terms of creativity indicators, than the students of the first school, even though the students from the first school were familiar with posing problems from artifacts from their past study. It should, however, be noted that the second school had more students with averages in the medium-high range in mathematics. This might suggest that there is a correlation between the creativity and the performance in mathematics; this aspect deserves to be investigated in a subsequent study.

With regard to the problem-solving phase, this appears to be important and helpful in allowing a better understanding of the initial situation, fostering quality control of the problems created by the students themselves, and giving a starting point for analyzing the structure of problems.

By solving the problems created by their peers, the students become able to analyze them in a more detached and critical way. For example, students reflected on what information was really important and what was not, and discovered that numerical information is not always the most important information contained in the text of a problem, as the following discussion illustrates:

It's Giulia's birthday and she invited 9 people to her birthday party, but she didn't benefit from the "pacchetto festa" (party package), how much did Giulia pay for her entrance?

Almost all of the students did not read the words of the problem question carefully, because a lot of students calculated the total and not only Giulia's entrance cost. In fact the total number of people (9) in the problem was superfluous.

The problems solved by the children of the first school allowed them to make estimate: the children have thought about what happens in everyday life in order to estimate the

possible solution of the problem. Presenting children problems with insufficient data has allowed them to better understand the artifact and the text of the problem itself.

The results obtained, checked also in another study we conducted (see e.g. Bonotto, 2005 and 2009), show that an extensive use of suitable cultural artifacts, with their associated mathematics, can play a fundamental role in bringing students' out-of-school reasoning and experiences into play by creating a new dialectic between school mathematics and the real world.

With regard to the artifact utilized, on the one hand it was particularly attractive inasmuch as it referred to an amusement park known to the children, while on the other hand it was also very dense with information. The latter aspect was desirable because it furnished conditions allowing students to formulate hypotheses regarding the various possibilities offered. Students were therefore able to create diverse problems with differing degrees of difficulty. However, the artifact also revealed some weak points: it was rather complicated in its language and presented some information only implicitly. Students, in fact, did not know some terms of everyday language (for example lunch voucher, one free entry every 10 entries) and several mathematical terms (for example minimum, at least).

Despite the richness of variables and linguistic limits of the artifact, the majority of the pupils nevertheless succeeded in understanding it and in carrying out both the problem-posing and problem-solving activities. Moreover, the brochure's complexity improved lexical enrichment, favoured the development of interesting discussions (which we did not report here), and stimulated the students to ask themselves questions and formulate hypotheses, that is to "problematize the reality".

However, in order to have better performance on the problem-posing task in terms of the greater number of plausible problems, with more complex tests and concatenated questions, it proved to be important to structure, organize, and summarize the information present in the brochure. In fact, students who had previously performed this type of analysis outperformed the others in the problem-posing activity. With regard to this aspect, the first school students, who were already familiar with this type of activity, have done better analysis and synthesis of the artefact by producing fewer implausible problems. Instead, about one-third of the problems produced by the second school students were implausible problems.

CONCLUSION AND OPEN PROBLEMS

The real life artifact (also the computer, as well as other more recent multimedia instruments) reflects the complexity of reality and so it offers a rich setting for raising issues, asking questions and formulating hypotheses. When choosing an artifact it is necessary to evaluate its complexity, including the number of constraints and variables that arise. In fact, these factors can stimulate discussions, questions and the formulation of hypotheses, or can inhibit them.

It is interesting to reflect on the fact that in the study here presented there were good results for students accustomed to using real life artifacts (the classes from the first school) as well as those who have used them for the first time (the classes from the second school). This indicates that an artifact provides a useful context for the creation of problems and the mathematization of reality as a result of its accessibility to all students.

As was shown in the research conducted by Lowrie (2002), during an open task such as a problem-posing activity, the responses of students reflect the kind of teaching practiced and classroom experiences. In fact, many mathematical problems invented by the students involved in the study were similar to those found in their textbooks. Nevertheless some students also produced some original problems, open problems, or problems that allowed for more than one solution. This highlights the fact that pupils are able to deal with open-ended tasks. Here two questions arise: how the teaching influences these results? How could we change the mathematics teaching in order to encourage the process to invented non-standard problems and to favour the creativity?

Meanwhile, this experience shows the importance of combining the problem posing activity with the problem solving activity: the problem-solving phase, in fact, combined with group discussions, allowed students to reflect on different types of problems and explore new possibilities (e.g. suggesting that mathematical problems do not always require a numerical answer or a unique solution, and that there are problems which are not solvable).

Furthermore, the results of the classroom discussion suggest that asking students to analyze the problems they have created facilitated their critical thinking because students felt free to discuss the validity of the problem, to consider different assumptions, and to decide whether a problem had been solved or not.

In future research, we would like to investigate through further studies:

- i) the correlation between students' academic performance in mathematics and their performance in the three categories considered to assess creativity (fluency, flexibility, and originality),
- ii) how classroom teaching practices and experiences influence the creativity processes, and
- iii) if the method to identify and assess the creativity in problem posing situations, developed in this study, could be exported (fully or in part) in problem solving situations.

REFERENCES

- Bonotto, C. (2005). How informal out-of-school mathematics can help students make sense of formal in-school mathematics: the case of multiplying by decimal numbers. *Mathematical Thinking and Learning. An Intern. Journal*, 7(4), 313–344.

- Bonotto, C. (2009). Working towards teaching realistic mathematical modelling and problem posing in Italian classrooms. In L. Verschaffel, B. Greer, W. Van Dooren, and S. Mukhopadhyay (Eds.), *Words and worlds: Modelling verbal descriptions of situations* (pp. 297–313), Rotterdam: Sense Publishers.
- Cai, J., and Hwang, S. (2002). Generalized and generative thinking in US and Chinese students' mathematical problem solving and problem posing. *Journal of Mathematical Behavior*, 21(4), 401–421.
- Dunker, K. (1945). On problem-solving. *Psychological Monographs*, 58 (5, Whole No.270).
- Ellerton, N. F. (1986). Children's made-up mathematics problems - a new perspective on talented mathematicians, *Educational Studies in Mathematics*, 17(3), 261–271.
- English, L. D. (1998). Children's problem posing within formal and informal contexts. *Journal for Research in Mathematics Education*, 29(1), 83–106.
- Freudenthal, H. (1991). *Revisiting mathematics education. China lectures*. Dordrecht: Kluwer.
- Guilford, J. P. (1950). Creativity. *The American Psychologist*, 5(9), 444–454.
- Kilpatrick, J. (1987). Problem formulating: where do good problems come from? In A. H. Schoenfeld (Ed.), *Cognitive science and mathematics education* (pp. 123–147). Hillsdale, NJ: Lawrence Erlbaum Associates.
- Kontorovich, I., Koichu, B., Leikin, R., and Berman, A. (2011). Indicators of creativity in mathematical problem posing: How indicative are they? In M. Avotina, D. Bonka, H. Meissner, L. Sheffield, and E. Velikova (Eds.), *Proceedings of the 6th International Conference Creativity in Mathematics Education and the Education of Gifted Students* (pp. 120–125). Latvia: Latvia University.
- Leung, S. S. (1997). On the role of creative thinking in problem posing. *Zentralblatt für Didaktik der Mathematik*, 97(3), 81–85.
- Leung, S. S., and Silver, E. A. (1997). The role of task format, mathematics knowledge, and creative thinking on the arithmetic problem posing of prospective elementary school teachers. *Mathematics Education Research Journal*, 9(1), 5-24.
- Lowrie, T. (2002). Designing a framework for problem posing: young children generating open-ended tasks. *Contemporary Issues in Early Childhood*, 3(3), 354–364.
- Saxe, G.B. (1991). *Culture and cognitive development*. Mahwah, NJ: Erlbaum.
- Silver, E.A. (1994). On mathematical problem posing. *For the Learning of Mathematics*, 14(1), 19–28.
- Silver, E.A. (1995). The nature and use of open problems in mathematics education: mathematical and pedagogical perspectives. *Zentralblatt für Didaktik der Mathematik*, 27(2), 67-72.

- Silver, E. A. (1997). Fostering creativity through instruction rich in mathematical problem solving and problem posing. *Zentralblatt für Didaktik der Mathematik*, 29(3), 75–80.
- Silver, E. A., and Cai, J. (1996). An analysis of arithmetic problem posing by middle school students. *Journal for Research in Mathematics Education*, 27(5), 521–539.
- Silver, E. A., and Cai, J. (2005). Assessing students' mathematical problem posing. *Teaching Children Mathematics*, 12(3), 129-135.
- Siswono, T.Y.E. (2010). Leveling students' creative thinking in solving and posing mathematical problem. *Indonesian Mathematical Society Journal on Mathematics Education*, 1(1), 20–41.
- Sriraman, B. (2009). The characteristics of mathematical creativity. *Zentralblatt für Didaktik der Mathematik*, 41(1-2), 13–27.
- Stoyanova E., and Ellerton N. F. (1996). A framework for research into students' problem posing in school mathematics. In P. C. Clarkson (Ed.), *Technology in mathematics education* (pp. 518–525), Mathematics Education Research Group of Australasia: The University of Melbourne.
- Torrance, E. P. (1966). *Torrance tests of Creative Thinking*. Princeton N.J.: Personal Press.
- Verschaffel, L., De Corte, E., Lowyck, J., Dhert, S., and Vandeput, L. (2000). *Supporting mathematical problem solving and posing in upper elementary school children by means of Knowledge Forum*. Deliverable of project No. 2017 CL-Net: Computer Supported Collaborative Learning Networks in Primary and Secondary Education.
- Verschaffel, L., Van Dooren, W., Chen L., and Stessens K. (2009). The relationship between posing and solving division-with-remainder problems among flemish upper elementary school children. In L. Verschaffel, B. Greer, W. Van Dooren, and S. Mukhopadhyay (Eds.), *Words and worlds: Modelling verbal descriptions of situations* (pp. 143–160), Rotterdam: Sense Publishers.
- Yackel, E., and Cobb, P. (1996). Classroom sociomathematical norms and intellectual autonomy. *Journal for Research in Mathematics Education*, 27(4), 458–477.
- Yuan X., and Sriraman B. (2010). An exploratory study of relationships between students' creativity and mathematical problem posing abilities. In B. Sriraman, and K. Lee (Eds.), *The elements of creativity and giftedness in mathematics* (pp.5-28), Rotterdam: Sense Publishers.

MATHEMATICAL PROBLEMS IN BASIC EDUCATION

Virginia Furlanetto, Maria Madalena Dullius, Italo Gabriel Neide

Centro Universitário UNIVATES

virf@universo.univates.br, madalena@univates.br, italo.neide@univates.br

A major concern with respect to Basic Education in Brazil currently is how to improve the quality of teaching and learning. Aiming to contribute in this aspect, in the area of mathematics, we developed a research with the goal to investigate the possible influence of using distinct strategies to solve problems. This was applied with students of Basic Education when facing mathematical situations with the purpose to contribute for a satisfactory result. As a main result, we observed that the students started to make use of diversified problem solving strategies.

INTRODUCTION

Improving the quality of teaching and learning of Brazilian students is a recurring concern of teachers. Furthermore, mathematics courses are generally considered difficult by the students. The view of a perfect science, with equations and unique solutions, where memorization and mechanization in solving exercises predominates could be the cause of disappointment and evasion of the students. This factors can cause them to fail in mathematics courses, which seems to be so connected to our daily life and most professions. Thus, it becomes necessary to revise this process and discuss how problem solving can help in this issue.

The National Curriculum Parameters (*Parâmetros Curriculares Nacionais – PCNs*) (Brasil, 1998, p. 40) indicate that, “in the processes of teaching and learning, concepts, ideas and mathematical methods should be approached by problems exploration”. The solution of these problems is presented in the PCNs as a purpose related to most of the suggested content for different stages of Basic Education. Considering that solving a problem involves understanding of what was proposed and the presentation of solutions, applying appropriate procedures, it is noteworthy that there are several ways to achieve a distinct result, i.e., numerous are the strategies that students can use in this process.

In this context, we conducted the research presented here with the main goal “to explore the use of different strategies for solving mathematical problems with students of Basic Education and analyzing how these affect this process”.

For this purpose, initially, several classes of 8th grade (students with approximately fourteen years old), from six public schools were invited to solve a selection of eight problems, whose solutions were analyzed from the perspective of different strategies that can be used. The intent of the initial data collection was to identify how students solve problems, which strategies they use and what is the amount of correct answers. Then, in one of the schools, meetings with students of 7th and 8th grades of elementary

school were conducted. They faced mathematical problems and were encouraged to use different strategies for solving problems and sharing them. At the end, participants solved a new set of problems and participated in a semi-structured interview, which showed their opinions regarding the problem solving process and the use of differentiated strategies. In this paper we discuss the results of the intervention performed.

THEORETICAL FRAMEWORK

The theoretical assumptions guiding the development of this research are based on the approach of mathematics through problem solving focusing on the use of different strategies. The approach of mathematics through problem solving can contribute to the formation of more autonomous and critical citizens as the student becomes agent of their own learning, creating their methods and strategies for resolution in contrast to traditional methodologies, dominated by memorization and mechanization.

According to the PCN's (Brasil, 1998), problem solving can be seen as the starting point of mathematical activity in comparison to the simple resolution procedures and the accumulation of information, since it enables the mobilization of knowledge and information management that are at reach of the students. Mathematics educators agree that the ability to solve problems is one of the main objectives of the teaching and learning process of mathematics. Dante (2000) points out that the working with mathematical problem solving can be the main way to achieve the goals of mathematics in the classroom, among them, “to make students think productively”. The author also mention that:

More than ever we need active and participant people who must make quick decisions and, as far as possible, accurate. Thus, it is necessary to form mathematically literate citizens, who know how to solve, intelligently, their problems of commerce, economics, business administration, engineering, medicine, weather and other of daily life. And, for this, it is necessary that children have in their elementary mathematics curriculum problem solving as a substantial part, to develop in an early stage the ability of facing problem situations (Dante, 2000, p. 15).

As for problem solving, D'Ambrosio (1989) points out that often, students abandon the solving of a mathematical problem because they have not learned how to solve this type of question, i.e., they do not know the solution algorithm or the process that the teacher expects them to develop for that problem. According to the author, “students are missing a flexible solution and the courage to try alternatives, different ones proposed by teachers”. This kind of attitude can demonstrate apprehension on the part of those students to try different solutions from the proposed in the classroom, which inhibits the development of relevant features to civic education and to challenges of professions previously cited, such as creativity, autonomy and critical thinking.

In this regard, Cavalcanti (2001, p. 126) points out that the appreciation of the strategies used:

[...] inhibits inappropriate attitudes toward problem solving, for example, quickly abandon a problem when the technique is not identified, expect anyone to solve, keep asking what is the operation that solves the situation, or to believe that it is not worth to think deeply to solve a problem.

In the understanding of Musser and Shaughnessy (1997, p. 188), the emphasis of the curriculum of mathematics in the old school was spent in the learning of algorithms, due to the strong dominance of arithmetic existing at the time; however, in the electronic age we live in, the priority should be the development and the use of algorithms to solve problems. The authors cite five strategies to solve problems that they deem appropriate to be addressed in schools:

- Trial-and-error: application of relevant operations to the given information. Inferences and tests are performed to reach at a satisfactory result.
- Patterns: resolution of particular cases, finding patterns that can be generalized.
- Solve a simpler problem: resolution of a particular case or a temporary shift of a complicated problem for a short version, and may be accompanied by the use of a pattern.
- Working in reverse: starting from the result of what must be proved, perform operations that undo the original or search propositions to deduce the goal.
- Simulation: used when the solution of the problem involves conducting an experiment and to perform it is not practical.

Dante (2009, p. 61) presents some of these strategies and also the “Reduce to the unit”, similar to “Solve a simpler problem”, which relates to calculate initially different units from those presented in the problem statement, not necessarily reducing the unit 1, but the one that the resolver think is most convenient.

Cavalcanti (2001, p. 127) also cites the use of drawing “as a resource for interpretation of the problem and as a record of the solution strategy”, and the utilization of the conventional algorithm, i.e., the calculation related to the content involved in the problem as “one more possibility of resolution” (p. 143). Stancanelli (2001) introduced the use of tables as another possible strategy to organize data and solving problems.

Solving problems using differentiated strategies may also be related to aspects involving creativity, defined by Gontijo (2006, p. 4) as:

The ability to present numerous possibilities for appropriate solutions to a problem situation, so that they focus on distinct aspects of the problem and / or different ways to solve it, especially unusual ways (originality), both in situations requiring resolution and elaboration of problems as in situations that need the classification or organization of objects and / or mathematical elements in function of their properties and attributes, either textually, numerically, graphically or as a sequence of actions.

Research shows that one of the strategies most used by students in problem solving is the formal calculus (Dullius et al, 2011). However, the approach of mathematics

through problem solving, allowing the student to choose the path that he desires to achieve the solution, allows to go beyond the linearity of traditional education as the resolver can mobilize different knowledge to arrive at an answer.

METODOLOGY

The research was developed through a predominantly qualitative approach, because we believe that in addition to the view of the researcher, the necessity and importance of studying reality from the perspective of the researched subject. According to the technical procedures adopted for its development, the research was constituted of a study case that allows researchers, according to Yin (2010, p. 24), in retaining “the holistic and meaningful characteristics of real life events” and it was conducted by obtaining data from different sources of evidence.

The context of research and development of the proposal were five public state schools, all members of the Projeto Observatório da Educação (Observatory of Education Project) in which this investigation is inserted, and a public municipal school, in which the first author teaches. Students from 8th grade in these schools were asked to solve eight problems extracted from the Matriz de Referência da Prova Brasil (Reference Matrix of Test Brazil) evaluative quality system of Basic Education in Brazil. The students were also instructed to describe the procedures and reasoning employed in order to analyze the most used strategies.

The classification was developed from the categories: Drawing, Formal calculus, Tables, Trial and error, Organization of patterns, Working in reverse, Reduce to the unit. It was necessary the creation of an eighth category, which we called Elimination, with potential to be used in multiple-choice problems, wherein after the interpretation of the situation, the student can analyze the possible answers and discard, according to criteria established by him, some alternatives.

We note that the categorization of the solutions submitted by students, both in the initial data collection, and in other stages of the research was based on our experience as teachers and researchers and in the interpretation from the theoretical framework studied. It is possible that another researcher use other forms of classification. We also emphasize that some resolutions were grouped into more than one category, because they consist of a mix of strategies. For analysis and illustration of the resolutions, the written material produced by the students was enumerated using A1 to designate the student 1, A2 for student 2 and so on.

With this instrument of initial data collection we detected the predominance of Formal calculus as principal method of resolving most of the eight problems and, in some cases, associated with high rates of inefficiency, even exceeding 90%. Furthermore, it was also large the number of students who only marked the final answer, without no method development of solving problems. It was not possible to identify the reason. Concerned with this result, we were motivated to elaborate the second stage of the research. We developed an educational intervention aimed to stimulate students to

learn, create and use diverse strategies to solve mathematical problems, in the attempt to provide a possibility of to raise the level of success when students are facing mathematical problems.

The educational intervention involved classes of 7th and 8th grades of a public school, a total of eleven students who voluntarily joined the proposal developed in extracurricular school time in a ten weekly meetings. Two of these students were considered dropouts because they have not participated in all meetings. The choice of the school was mainly because of the possibility of performing the intervention in extracurricular school time, not interfering in this way in the registry of content of the school curriculum.

The educational intervention consisted of a teaching practice based on the use of different strategies for problem solving by students of Basic Education to verify if it has potential to contribute to the improvement of the process and, consequently, the quality of teaching and learning at this level of education. During these classes, where problems were proposed from Prova Brasil (Test Brazil), math olympics, textbooks, websites, etc..., we used the steps for solving problems posed by Polya (1995), stressing the importance of careful reading and identifying the unknown variable for a correct interpretation of the proposed situations. In this part of the process, discussions were held about the data problems and inquiries were also made to students in order to assist them in the interpretation.

However, the focus of research was on the step corresponding to the establishment of a plan where we encourage the use of diverse strategies, sharing those that have been used by students in other classrooms/schools, or even those that arise in the class itself and also among researchers who assisted in developing the proposal. In the implementation phase of the plan, the idea was that students could still improve the strategy outlined, would add details and had examined carefully each step. Regarding to retrospect, it occurred in order to share and discuss the strategies used for each problem, leading the participants to detect which of the forms was demonstrated more effective.

It is worth noting that during the meetings, were not introduced or explained contents involved, considering the intention of stimulating the search for alternative resolution strategies. In most of the meetings, students were organized in groups of two or three, sometimes chosen by themselves, sometimes through for technical or activity proposed by the teacher who led the pedagogical practice. In the next section we present some of the issues explored with examples of resolutions developed by students or groups, with considerations regarding the same.

DATA ANALYSIS

The problem shown in Figure 1 was solved by the group formed by A6 and A7 and generated several questions. The first difficulty was the interpretation of the problem, but after questions, students understood that the sequence of pieces should continue.

They noticed that the increase was four tiles for each piece, then they wrote beside each piece the number of tiles. After, they added all parts to reach 330 tiles, erasing the annotations concerning surplus parts they had written. When they exposed the resolution, I suggested the use of a table, where they could write, in the 3rd column, the total amount of tiles that make each piece in the sequence.

Usando ladrilhos quadrangulares, Ana decorou uma parede, conforme mostrado, parcialmente, na seqüência de peças abaixo:

1ª peça 2ª peça 3ª peça 22, 26, 30, 34, 38, 42, 46
50;

Sabe-se que Ana seguiu o mesmo padrão estabelecido na figura acima no desenho das demais peças com as quais decorou a parede. Quantos ladrilhos quadrangulares foram necessários na última peça de decoração, sabendo-se que Ana utilizou, ao todo, 330 ladrilhos?

	4
	10
	14
	18
	22
+	26
	30
	34
	38
	42
	46
	<u>50</u>
	330

Figure 1. Problem proposed to A6 and A7 and solution using the strategy of Trial and error (Problem extracted from Haetinger et al (2008)).

In research performed about the strategies used by participants in a Math Olympiad, Dullius et al (2011) also detected the predominance of the same strategy in the resolutions presented to the same problem.

The second problem (Figure 2) with the resolution proposed by A9 involved comparing fractions. It was correctly solved by the majority of students utilizing the strategy of drawing.

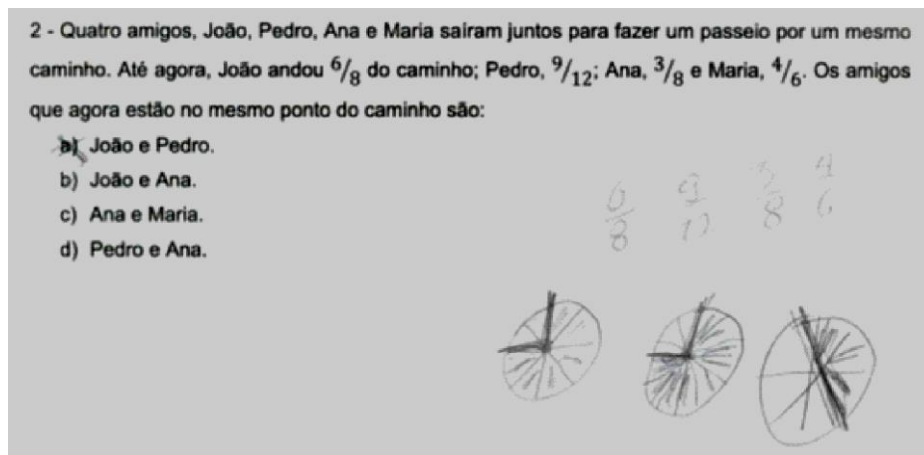

Figure 2. Problem two: solution and strategy of drawing utilized by A9 (Problem extracted from Brasil (2008a))

In the proposed solution the students transcribed the fractions, but they did not simplify it, they just drew them in the same sequence, confirming that the paths of “João” and “Pedro” were equal. Only two of them used the calculation, succeeding too. During the discussion it was mentioned to the students that, when solving each new problem, we can also use knowledge and strategies already used in old problems. Polya (1995, p. 40) suggests that “recalling previously resolved issues, which have the same or a similar unknown [...], we have a good chance of starting in the right direction and we can devise a plan for a resolution”.

In Figure 3, we show problem fifteen and the resolution proposed by A9. The chosen strategy was Trial and error and it was used correctly by all students. Some students associated this strategy with another one, the drawing, used to assist in the interpretation. According to Cavalcanti (2001), this is another possible strategy.

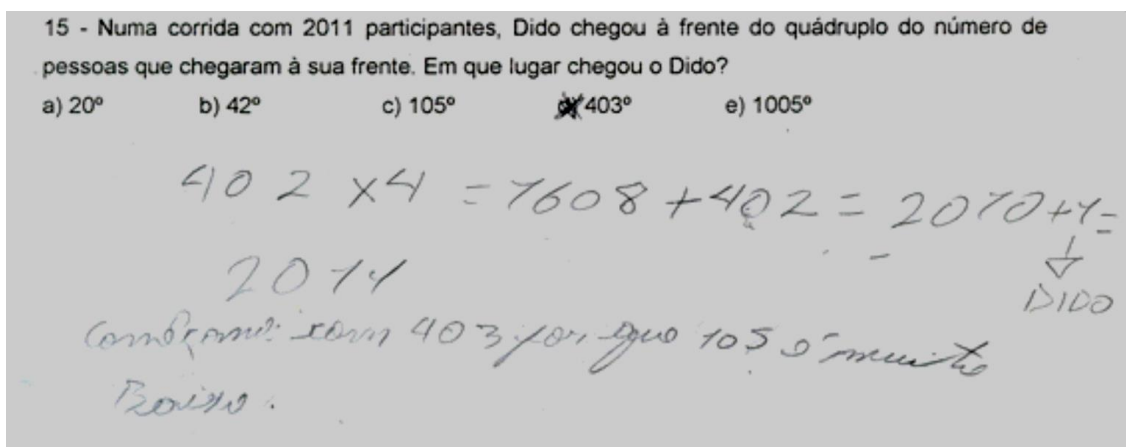

Figure 3. Problem fifteen and solution by A9 using the strategy of Trial and error (Problem extracted from IMPA/OBMEP 2012).

The student chose to test all alternatives. First subtracting all by one and multiplying each of them by four, representing in this way the participants who arrived after “Dido”. Finally adding this result to the respective value of the main character. The fact that they started trying with the number 403 reveals a more thorough analysis of this group, compared to others who have tested all possibilities. The student reported in its resolution: “we started with 403 because 105 is too low”, which shows that he estimated the possible outcome for each option before performing tests and verifying the answer.

One group had started testing with other numbers, not seeming to realize that there were alternatives and that the response should be one of them. When I questioned them and was sure that they were testing random possibilities, I just pointed the alternatives, the time in which its components concluded that there was no need to test so many numbers, but only those five representing the alternatives. No group mentioned or tried to organize an equation to solve this problem.

This problem generated many questions, because most of the students could not understand the statement “arrived ahead of the quadruple number of people who came before him”. It was necessary to read several times and some realized that drawing a simplest situation could help in the interpretation of this data. It was the case of A6, which drew Figure 4 and questioned:

Student A6: So this is it, this is “Dido”: Four people came in front of him, sixteen came back?

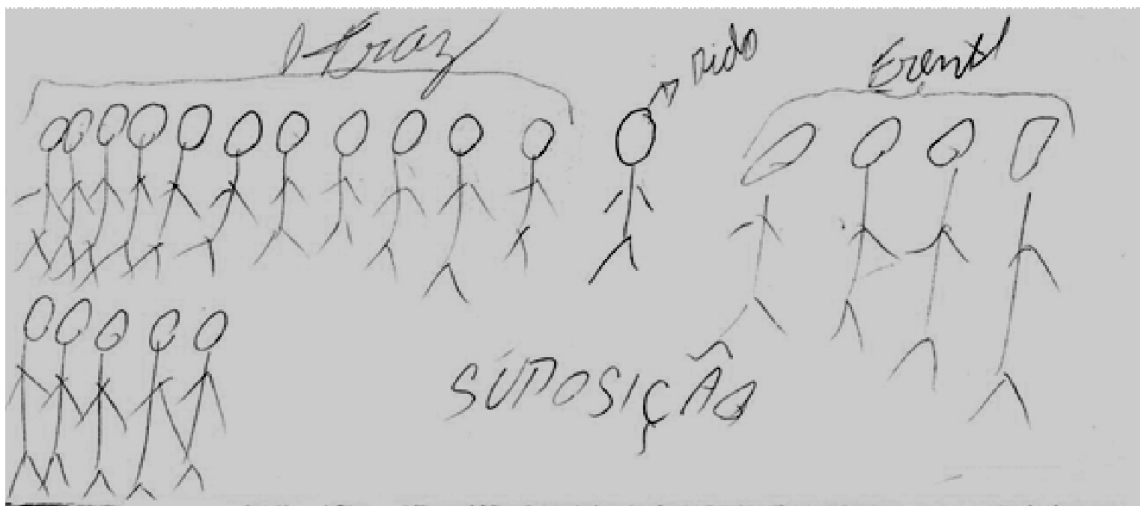

Figure 4. Drawing by A6 used to assist in the interpretation of problem fifteen.

In the solution proposed for problem nineteen we evidenced that one pair of students associated recognition patterns to drive reduction strategy. This solution can be seen in Figure 5.

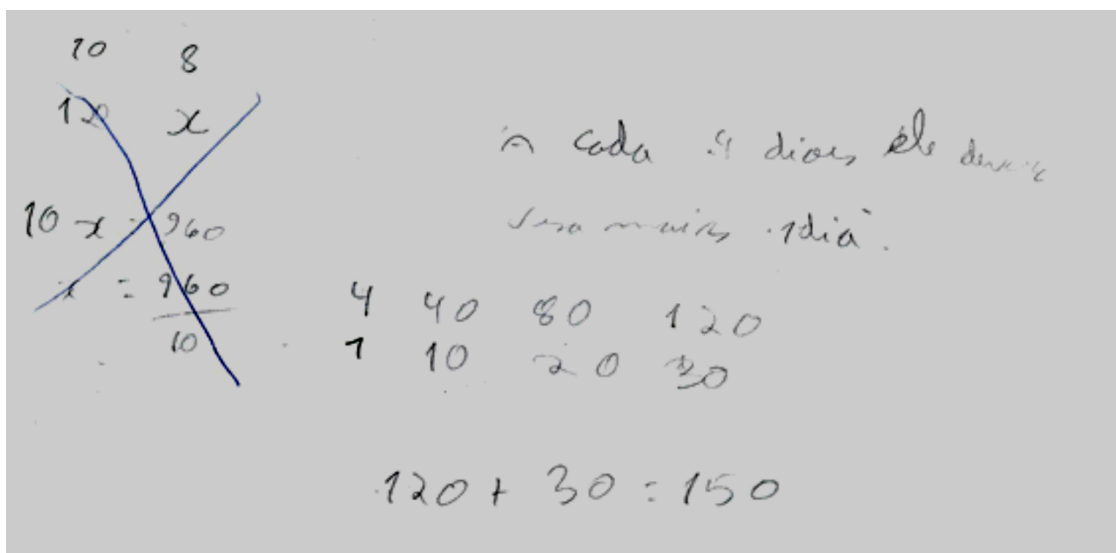

Figure 5. Resolution by A4 for problem nineteen using the strategies of organize patterns and reduce to the unit.

Students who developed this resolution had also started using the rule of three as if the situation were directly proportional, but when alerted to check the answer, they detected the impossibility of that solution and devised a new plan. They realized, as detailed in their solution that every four days worked with the reduced workload would require one day to work harder to compensate:

Student A4: every 4 days it should 'use' 1 more day.

Then, they made the next relationships based on the later, as it can be seen in the example, concluding that it would take thirty more days of work. This strategy has surprised us because we had not seen this possibility of resolution, which comes once again to demonstrate the ability of students to think about creative solutions when allowed to test their ideas.

At the end of the experience time and the contact of the students with the use of diverse strategies, they solved a selection of problems again. The responses were analyzed and categorized, noting that the investigation participants started using the strategies presented or discussed during the classes effectively.

FINAL CONSIDERATIONS

With the development of the research presented here we can state our quest as to encourage students to use and share different ways of problem solving, since formal calculation can not always achieve the correct answer or leads to the understanding of what they are doing. Concerning about the initially data collected in order to investigate the different strategies used by students in solving mathematical problems, we found a predominance of formal calculation as a way of solving problems, leading, in some cases, to a low rate of success.

During the educational intervention, analyzing the material produced by the participating students, we found that students were able to use, effectively, a variety of strategies for solving problems such as: trial and error, drawing, tables, working in reverse, reduction to the unit, organization patterns and elimination. Some of them were not even thought for us teachers, thus demonstrating the stimulation of creativity and autonomy provided by this form of work.

We attribute the fact that they used a wide range of problem solving strategies to the stimulus offered directly for this purpose and this has been one of the objectives pursued since the beginning of the research. The students used mixed strategies, especially drawing, including to help in the interpretation of certain situations. This difference with respect to the initial data collection may be related to the fact that it was never demanded the utilization of formal algorithms, also never discussed or presented content of mathematics. Thus, therefore, they managed to extend the repertoire of strategies that can be used in solving problems

We emphasize that we do not intend to suggest the elimination of the teaching of formal content of school mathematics, but we consider important that the students can also have the opportunity to learn the various strategies that can be used. Hence the students may choose, when elaborating a solution plan for solving problems, a convenient strategy that they judge to be the most appropriate to act as a facilitator process. When faced, for example, with problems involving contents of an entire year or more, students may forget details that make all the difference in achieving correct answers by using the formal calculation, whereas knowing problem solving strategies can adapt them to different contexts and succeed.

REFERENCES

- Brasil, S. de E. F. (1998). *Parâmetros Curriculares Nacionais: Matemática*. Secretaria de Educação Fundamental. Brasília: MEC/SEF.
- Brasil, M. da E. (2008). *PDE: Plano de Desenvolvimento da Educação: Prova Brasil: Ensino Fundamental: matrizes de referência, tópicos e descritores*. Brasília: MEC/SEB; Inep.
- Cavalcanti, C. (2001). Diferentes formas de resolver problemas. In K. S. Smole & M. I. Diniz (Orgs.). *Ler, escrever e resolver problemas: Habilidades básicas para aprender matemática* (pp 121-149). Porto Alegre: Artmed.
- D'Ambrosio, B. S. (1989). *Como ensinar matemática hoje? Temas e Debates*. SBEM. Ano II. N2 (p. 15-19). Brasília.
- Dante, L. (2000). *Didática da resolução de problemas de matemática: 1ª a 5ª series* (12. ed.) São Paulo: Ática.
- Dante, L. (2009). *Formulação e resolução de problemas de Matemática: teoria e prática* (1. Ed.) São Paulo: Ática.

- Dullius, M. M. et al. (2011). Estratégias utilizadas en la resolución de problemas matemáticos. *Revista chilena de educación científica*,1, 23-32.
- Gontijo, C. H. (2006). *Resolução e Formulação de Problemas: caminhos para o desenvolvimento da criatividade em Matemática*. In Anais do Sipemat. Recife, Programa de Pós-Graduação em Educação-Centro de Educação – Universidade Federal de Pernambuco.
- Haetinger, C, et al. (2008) *Anais da XI Olimpíada Matemática da UNIVATES*, 10 de setembro de 2008. Lajeado, RS: UNIVATES.
- IMPA/OBMEP (2012). *Banco de Questões 2012*. Rio de Janeiro: IMPA.
- Musser, G. L.; Shaughnessy, J. M. (1997). Estratégias de resolução de problemas na matemática escolar. In S. Krulik, & R. E. Reys (Orgs.) *A resolução de problemas na matemática escolar* (pp. 188 – 201). Tradução de Hygino H. Domingues e Olga Corbo. São Paulo: Atual.
- Onuchic, L. de L. R.; Allevato, N. S. G. (2004). Novas reflexões sobre o ensino-aprendizagem de Matemática através da Resolução de Problemas. In M. A. V. Bicudo, & M. C. Borba (Orgs.). *Educação matemática: pesquisa em movimento* (pp. 213-231). São Paulo: Cortez.
- Polya, G. (1995). *A arte de resolver problemas: um novo aspecto do método matemático*. Tradução e adaptação de Heitor Lisboa de Araújo. Rio de Janeiro: Interciência.
- Stancanelli, R. (2001) Conhecendo diferentes tipos de problemas. In K. S. Smole & M. I. Diniz (Orgs.). *Ler, escrever e resolver problemas: Habilidades básicas para aprender matemática* (pp 103-120). Porto Alegre: Artmed.
- Yin, R. K. (2010). *Estudo de caso: planejamento e métodos*. (4. ed.) Tradução de Ana Thorell. Porto Alegre: Bookman.

DIMENSIONS OF MATHEMATICALLY CREATIVE PROCESSES IN EARLY CHILDHOOD

Melanie Münz

University of Frankfurt/IDeA Center

muenz@math.uni-frankfurt.de

The paper deals with mathematically creative processes in early childhood. Therefore the concept of the interactional niche in the development of mathematical creativity is introduced, which combines interactionistic theories of socio-constructivism with sociocultural theories and a psychoanalytically based attachment theory to describe mathematically creative processes of children under the specific perspective of early childhood development. Data are collected in the interdisciplinary project MaKreKi (mathematical creativity of children), in which researchers from mathematics education and psychoanalysis examine the development of mathematical creativity of children in the age range of 4-8 years.

INTRODUCTION

Definitions of mathematical creativity differ in several assumptions. On the one hand creativity referred to as the individual ability of a person in the sense of divergent thinking (Guilford, 1967), the abilities to produce fluent, flexible, novel and elaborated solutions to a given problem (Torrance, 1974) or the ability to produce unexpected and original work, that is adaptive (Sternberg & Lubart, 2000). On the other hand creativity is seen as embedded in a social process (e.g. Csikszentmihalyi, 1997; Sriraman, 2004; Vygotsky, 2004), in which creativity is not solely located in a person's cognition, but is also accomplished in the social interaction among interlocutors.

My research interest is the examination of mathematical creativity in early childhood under the specific perspective of early childhood development. In this contribution I focus on the social and sociocultural approach to creativity. The first section presents a theoretical approach that deals with the question in which forms of social interactions these early mathematically creative interactions of children are caused and supported. Afterwards I define what is understood as a mathematical creative process in early childhood. Finally I clarify which cultural and sociocultural dimensions should be considered in a theory of mathematical creativity in early childhood, and in what way. After that an overview of data collection and methods is given. Next an empirical case follows. The paper ends up with summary and prospect.

THEORETICAL APPROACH

In many fundamental works on children's creativity, play has been regarded as a location in which creative actions arise and eventually are fostered (e.g. Bateson & Martin, 2013; Vygotsky, 2004,). Also from a psychoanalytical perspective play has been

regarded as a location where children's creativity is formed (Winnicott, 2012). According to Winnicott play is neither part of the personal inner reality nor part of the actual external reality but of a third dimension, that he indicates as "potential space" (Winnicott, 2012, p.144). As soon as a child experiences his or her mother no longer as part of his or her own, a "playground" (Winnicott, 2012, p. 64) emerges, that the child can use for playful creation. This is a complex process and it depends highly on a mother, who is willing to participate and to reciprocate. Winnicott calls her the "good enough mother" (p.109), who is sensitive and reacts appropriate to her child's needs in opposition to the "not good enough mother" (p.109).

Developing a theory of mathematical creativity in the early years one has also to consider the development of mathematical thinking as well. From a sociocultural perspective children's play is also considered as location of the development of mathematical thinking (e.g. Carruthers & Worthington, 2011; van Oers, 2002) and for this reason the development of mathematical creativity, too, is at least implicit. Mathematics comes into play through articulation by more knowledgeable people, "their companions in the cultural community" (van Oers 2002, p. 30). If play involves other more knowledgeable persons like children or adults, opportunities for scaffolding (Bruner, 1986) or guided participation (Rogoff, 2003) emerge. Besides the aspect of children's play with competent partners, children are dealing with mathematics in their free self-initiated play as well as in play situation with peers (e.g. Carruthers & Worthington, 2011).

Mathematical creative processes in early childhood

In several publications of the MaKreKi-project we have shown that "non-canonical" (e.g. Münz, 2014) solving processes can be seen as mathematically creative processes. They include the following aspects (Krummheuer, Leuzinger-Bohleber, Müller-Kirchhof, Münz, & Vogel, 2013; Sriraman, 2004):

Combinational play: Under this aspect the accomplishing of unusual combinations of insights and experiences and the sense of playfulness in the manipulation of procedures and its transfer to new areas are understood. With reference to Finke (1990) these activities are summarized with the "combinational play" (p. 3) of framing a mathematical situation.

Non-algorithmic decision-making: According to Ervynck (1991), mathematical creativity articulates itself when a unique and new way of problem solving emerges. For the age group of interest, processes of problem solving can be new, creative and unique, although they are not new for the mathematical community. Uniqueness can be seen as the "divergence from the canonical" (Bruner, 1990, p. 19) way of solving a mathematical problem in early childhood, that adult mathematicians would not necessarily expect.

Adaptiveness: Sternberg and Lubart (2000) characterize creativity as the ability to create an unexpected and original result that is also adaptive to the given real situation.

We have redefined this concept to our specific needs. *Adaptiveness* in MaKreKi describes children's ability to accomplish unusual definitions of situations and to convince their partners by their alternative framing of the situation. So a mathematical creative action has to be reasonable, which means there are arguments, why the chosen combination or unusual definition of the situation leads to a mathematically correct solution (e.g. Lithner, 2008). Additionally these arguments have to be somehow mathematically founded (e.g. Lithner, 2008; Münz, 2014).

Social and sociocultural dimensions

As already mentioned a theory of mathematical creativity has to consider social and sociocultural dimensions of creativity, because creative behavior is a complex person-situation interaction. I introduce a framework, which stresses these interactive structures and in which the emerging *creative process between* children is regarded as an aspect of interactive *process* of negotiation of meaning between the involved persons.

Developing a theory of mathematical creativity in the early years one has also to consider the development of mathematical thinking as well. According to my research focus, the “concept of the *interactional niche in the development of mathematical thinking (NMT)*” of Krummheuer (2012) seems appropriate for several reasons. For a start the NMT describes the situational aspect in the development of mathematical thinking as a process of negotiation of meaning between the involved persons. So it allows the description of this negotiation of meaning in a creative process as well and is able to capture insights about this creative process. Additionally another procedural aspect is described in the form of the cooperation of the involved persons and the individual scope of action of a child. The NMT is a further development of the original components of the “developmental niche” of Super and Harkness (1986), who describe it

... as framework of studying cultural regulation of the micro-environment of the child, and it attempts to describe the environment from the point of view of the child in order to understand processes of development and acquisition of culture. (p. 552).

Additionally Krummheuer added the aspect of interactively local production of such processes, which includes besides the aspect of allocation (under which the provided mathematical activities of a group are summarized, see table 1) the aspect of situation (situationally emerging accomplishment occurring in the process of meaning making) and the aspect of action (which covers the individual contributions to the actions as well as the individual participation profile of a child), which can be adopted to the theory of mathematical creativity in early childhood to examine the mathematical *creative process*. To describe a mathematical *creative process* in early childhood, in the following the fourth line of Krummheuer's NMT “aspect of action” (Krummheuer & Schütte, 2013) is renamed as the *aspect of individual's creative action*. It highlights the used mathematical concepts by the individual child, which can be regarded as

combinational play, divergence from canonical and adaptive, as well as the individual profile of participation of the child (see table 2).

Table 1. The NMT of Krummheuer (Krummheuer & Schütte, 2013).

	Component: Content	Component: Cooperation	Component: Impartation
Aspect of allocation	Mathematical domains; Bodies of tasks	Institutions of education; Settings of cooperation	Scientific theories of mathematics education
Aspect of situation	Interactive negotiation of the theme	Leeway of participation	Folk theories of mathematics education
Aspect of action	Individual contributions to actions	Individual profile of participation	Competency theories

Krummheuer has furthermore divided these aspects into three components: *content*, *cooperation* and *impartation* (Krummheuer & Schütte 2013), which I briefly summarize and emphasize their relevance to a theory of mathematical creativity in early childhood:

Content: The following data are collected in the MaKreKi-project, in which on the level of allocation mathematical topics are usually designed as mathematical situations of play and exploration (Vogel, 2013), regarding the children’s assumed mathematical competencies. They offer opportunities for children to demonstrate their mathematical creative potential. An accompanying adult, who can be seen as a more knowledgeable person, presents the situations. On the situational level this presentation generates processes of negotiation. The presentation of the mathematical situations of play and exploration and the processes of negotiations lead to individual mathematically creative actions.

Cooperation: Children participate in culturally specific social settings, which are variously structured as in peer-interaction or small group interaction guided by a more knowledgeable person. These social settings do not succeed immediately. They need to be accomplished in the joint interaction. Depending on each event, a different “leeway of participation” (Brandt, 2004) of the children will come forward. By embellishing these possibilities of participation every child has an individual profile of participation, which can be relatively stable over a given time (see Brandt, 2004).

In the limited frame of the paper I will not focus on the component *Impartation*, but for the sake of completeness, in this column Krummheuer investigates the influence of scientific as well as folk theories of mathematics education on the development of mathematical thinking (Krummheuer & Schütte, 2013).

Psychoanalytical dimensions in mathematically creative processes

To integrate psychoanalytical insights about creativity in early childhood I add another column, the component interpersonal relations, that derives from Winnicott’s concepts

of the “good enough mother” (Winnicott, 2012, p.109) as a requirement for the “potential space” (p. 64, p. 135) as the origin of creativity in human life, which I added in a third column (see table 2).

Interpersonal relations: According to Winnicott the initiation of playing is associated with the life experience of the baby who has come to trust the mother figure (Winnicott, 2012), which is given when she reacts sensitively and warmly to the child’s needs. In the first years of life the child develops an ‘inner working model’ through child-parents-interactions (Bowlby, 1969). This ‘inner working model’ contains the early individual bonding experiences as well as the expectations, which a child has towards human relationships, derived from these experiences. They induce the child to interpret the behavior of the caregiver and to predict his or her behavior in certain situations. After the first year of life this ‘inner working model’ becomes more and more stable and turns into a so-called “attachment pattern” (Bowlby, 1969, p.364). The quality of the child-caregiver relationship in sense of the attachment patterns can be measured (Ainsworth, Blehar, Waters & Wall, 1978). A rough distinction can be made between two types: The secure and the insecure attachment pattern. Children with a secure attachment pattern have, thanks to their sensitive mothers, a chance to build up secure relationships to them in which the whole spectrum, of human feelings in the sense of communication with each other can be perceived, experienced and expressed. Children with insecure attachment patterns experiences a mother who shows no intense affects and behaves in a distanced controlled manner or who sometimes reacts appropriately, and at other times is rejecting and overprotective, on the whole, inconsistent in a way that is unpredictable for the child. Empirical observations of infant’s exploratory behavior as well as children’s play behavior point out, that children with a secure attachment pattern show more exploratory behavior more positive affect, and are more cooperative in their play than children with an insecure pattern (e.g. Creasy & Jarvis, 2003). Also the quality of the play seems to depend on the attachment pattern. Following Crowell and Feldman (1988), parents of children with insecure attachment pattern are focusing on basic task completion rather than on learning processes.

On the level of allocation this attachment pattern can be regarded as stable (Bowlby, 1969), nevertheless Bowlby suggests that these attachment patterns may change as the child begins to interact with other attachment figures e.g. siblings, peers, teachers (Bowlby, 1969). So on the level of situation a child with an insecure attachment pattern may meet other children or adults who show sensitivity to his or her needs in the sense of being a “good enough” partner (Winnicott, 2012, p. 109), which enhances his or her potential for cooperation during the interactive process and potential in mathematical activities. The reverse conclusion is also conceivable. Regarding the aspect of individual creative action, the “good enough partner” will accept the contributions of the child to the mathematical process. This acceptance has not only to be understood as a shared meaning, it can also be seen as an interim, in which the involved persons have squared their framings of the situation and concluded that there is more than one possibility of framing. If this is not the case, the creative process somehow fails in the

concrete situation. The following table summarizes the additions to the concept of NMT, which I term as the “interactional niche of the development of mathematical creativity” (NMC):

Table 2. The NMC.

	Content	Cooperation	Interpersonal Relations
Aspect of allocation	Mathematical domains; Bodies of tasks; mathematical potentials	Institutions of education; Settings of cooperation	Attachment Patterns of the involved persons
Aspect of situation	Interactive negotiation of the theme	Leeway of participation	Situational emerging of attachment patterns
Aspect of individual’s creative action	Individual mathematically creative actions	Individual profile of participation	Acceptance in form of shared meaning or interim

EMPIRICAL APPROACH & METHODOLOGY

The sample of MaKreKi is based on the original samples of two projects that are conducted in the “Center for Individual Development and Adaptive Education of Children at Risk” (IDeA) in Frankfurt, Germany. One project is a study of the evaluation of two prevention programs with high-risk children in day-care centers (EVA). It examines approximately 280 children. The second project is a study of early steps in mathematics learning (erStMaL). This project includes approximately 150 children. Thus the original sample contains 430 children. We asked the nursery teachers of the two original samples, whether they knew children in their groups who show divergent and unusually sophisticated strategies while working on mathematical tasks. We could identify 37 children, who seem to work creatively on mathematical problems.

For the examination of the development of mathematical creativity in the selected children, we introduced mathematical situations of play and exploration (Vogel, 2013) constructed in the erStMaL-project. They are designed in a way that the children can demonstrate their mathematical potential in the interactive exchange with the other participants. An accompanying adult presents the material by sparingly giving verbal and gestural impulses. To ensure that the implementations of these mathematical situations are independent of the participating individuals and proceed in comparable ways, the mathematical situations of play and exploration are explicitly described in design patterns of mathematical situations (Vogel, 2013). With respect to the longitudinal perspective, the children are observed every six months while they work on two mathematical situations of play and exploration. All these events are video taped with two cameras.

For the diagnosis of the attachment pattern we apply the Manchester Child Attachment Story Task, so-called MCAST (Green, Stanley, Smith & Goldwyn, 2000). This is a story telling test that has good reliability and validity.

Regarding the theoretical considerations and the attempt to identify mathematically creative moments in mathematical interactions of preschool children, in the following there is an analysis of interaction conducted, which is based on the interactional theory of learning mathematics (Brandt & Krummheuer, 2001). It focuses on the reconstruction of meaning and the structure of interactions. Therefore it is proper to describe and analyze topics with regard to contents and the negotiation of meaning in the course of interactional processes. The negotiation of meaning takes place in interactions between the involved people. These processes will be analyzed by an ethnomethodologically based conversation analysis, in which it is stated that the partners co-constitute the rationality of their action in the interaction in an everyday situation, while the partners are trying constantly to indicate the rationality of their actions and to produce a relevant consensus together. This is necessary for the origin of their own conviction as well as for the production of conviction with the other participating persons. This aspect of interaction is described with the term “accounting practice” (Lehmann, 1988, p. 169). To analyze these “accounting practices” of children in mathematical situations, the reconstruction and analysis of argumentation of Toulmin (1969) have proved to be successful.

VICTORIA AND SINA IN THE “SOLID FIGURE-SITUATION”

Information about the girls and the “Solid figure-Situation”

Victoria (4;10 years old) and Sina (4;6 years old), both have a secure attachment pattern, participate in the “Solid-figure-Situation”. They are close friends.

In the mathematical situation of play and exploration “Solid-figure” the attending children deal with geometrical solids: Cube, square column, pyramid, triangular prism, cone, cylinder and sphere, each of them is duplicated. The material and the designed impulses of the accompanying person provide a geometrically mathematical content for the children in whom they are getting to know these solids and their properties. To enable the children to focus their attention more easily on the geometric figures, a little bag in which the children feel them is used.

“...because this is a gyroscope”

At first the female accompanying person (abbreviated B in the following) calls on both girls to handle the cone and describe what they have touched. Afterwards she puts a red cube, a red pyramid and a blue cylinder on the table. The children grab and term each solid unrequested: The cone has been designated as “castle” by Victoria and “hat” by Sina, the cube as “cube”, the cylinder as “gyroscope” and the pyramid has been identified as “cornflake” by the group. In this context Sina inquires if they have to build a castle and begins to put some solids on top of each other. B negates and presents a little bag, in which she has put a cylinder, what the children have not seen. She invites the girls to find out, which solid is located in this bag only by touching and gives the clue that the solid in the bag is also arranged on the table. Therefore every girl has to feel the unknown solid in the little bag. Victoria starts and says: “A gyroscope. Next

Sina follows and says: “A gyroscope, too”. After validating their conclusion initiated by B the girls are adding together some solids to build towers. First they put two cylinders on top of each other and place the pyramid on the cube to see which one is the tallest tower. Then Victoria asks: “Should I fetch the yellow one?” and Sina answers: “Okay. Good. Come on.” and Victoria continues: “Then we can look which one is bigger”. Victoria places the cone and the pyramid side by side. Immediately thereafter Sina puts the pyramid on top of the cylinders and the cone on the cube and then interchanges cone and pyramid (Figure 3).

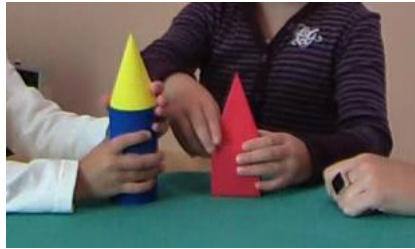

Figure 3. Towers

B asks: “Which one was the biggest Victoria? Have you seen it so fast?” And Victoria puts her right hand on the pyramid and says: “This one.” Whereupon B responds: “Put them down again. Than you can look again which one is bigger”. But Victoria looks at Sina’s towers and says by grabbing the cube-pyramid-tower: “Or Sina no. Do you know what? These ones belong to these ones“. And by touching the cone on top of the cylinders she notes: “And these to these ones”. Sina moves the double cylinder-cone-tower towards the cube-pyramid-tower and tells: “Bigger”. B looks to Victoria and wants to know why these solids belong together whereupon Victoria shrugs her shoulders and Sina responses: “This is red and red”, by touching the pyramid and the cube. And Victoria continues: “Yes because and look and this belongs to the gyroscope because this is a gyroscope”, she points at the double cylinder-cone-tower. Then she holds both hands at the cube-pyramid-tower, “because it“, and turns her hands and shows her palms.

Analysis of the episode of Victoria and Sina in the “Solid figure-Situation”

Regarding the component **content** on the level of *allocation* B provides a geometrically mathematical content for the children in whom they are getting to know solids and their properties. The task is to find identical solids. On the *situational* level this content is extended to build castles or towers (Sina), to find out which solid is the biggest one by direct size comparisons (Victoria) and to find similar solids, which belong together (Victoria). These extensions lead to the *mathematical creative action* of Victoria by grouping pyramid and cube as well as cylinder and cone together. Her *combinational play* in matching cylinder and cone is interpreted as the assignment of the solids regarding similar properties. This similar properties are expressed in Victoria’s terming of both solids as “gyroscope” (in German “Kreisel”). The german word “Kreisel” includes the word “Kreis” which is translated in English “circle”. Cylinder and cone have both circular base areas. In an analogous manner Victoria matches cube and

pyramid, which she constitutes in showing her palms, which can be portended as a non-verbal addressing of the base areas of the solids, because like cylinder and cone, cube and pyramid have also same base areas. Victoria's assignment of the solids can be regarded as a conclusion, *divergent from the canonical*, because the intended task of B was to find identical solids. Her conclusion seems *adaptive* to the group, because no one disagrees. However B invites her to explain her findings, which she does by using a plausible and mathematical underpinned warrant in emphasizing the same base areas of the solids, which has also a plausible and mathematical backing (solids with one equal property can be grouped together).

Regarding the topic **cooperation**, Victoria and Sina are paired in a dyad together with an accompanying person in their day-care center. They have to work on a task consecutively, because B addresses first Victoria and then Sina to feel the unknown solid. Summarizing B has the role of an *initiator* of tasks and *evaluator* of solutions while the girls have to process that task as *processors*. They are not allowed to build a castle. The polyadic changes to a more dyadic interaction structure between B and one girl, whereas Sina's referring to Victoria's solution "A gyroscope, too" focuses a maintaining of the polyadic interaction. B's initiation of an evaluation of the solution addresses both girls. After completing B's task the roles of the girls change. They are focusing Sina's idea of building towers and they *initiate* new tasks autonomously like the comparison of sizes. They realize a dyadic interaction between each other. B behaves more reserved her role shifts to a *facilitator*, who inquires, like her inviting of Victoria to say which solid is the biggest one. It seems somehow as she is one step behind the girls. At that time Victoria is able to conduct two dyadic discourses simultaneously between her and B and her and Sina. In the second one Sina puts cone and cylinder together as well as cube and pyramid. Victoria comments these activities with the idea that these solids belong together. Again B inquires further information, she asks Victoria for an explanation of these groupings. Sina's expression "Bigger" may refers to B's first question concerning the size comparison and her explanation of the grouping "This is red and red" answers B's second question, so again she focuses a maintaining of the polyadic interaction. In the polyadic discourse Victoria extends Sina's explanation with the evidence of the same base areas of the matched solids. So she can be seen as the *initiator* of this explanation why the matched solids belong together. Summarizing the girls' role changes from a *processor* to an *initiator* and the dyadic interaction structure turns to a polyadic ones.

Concerning the component **interpersonal relations** both girls have a secure attachment pattern, which mean that they show high exploratory behavior and cooperative strategies in their play. This has also been showed in the presented episode. In the concrete situation Sina shows endeavors in maintaining a polyadic interaction. Furthermore she supports Victoria in her idea of comparison of sizes ("Okay. Good. Come on."). Also Victoria supports Sina's idea of building castles or towers although B has rejected it. In terms of Winnicott Victoria has in Sina a "good enough" partner. B can also be seen as a good "enough partner", because she shows interest in Victoria's

conclusion and invites her to explain her findings. In the polyadic interaction a mathematical “playground” (ibid., p. 64) emerges, that enables Victoria to accomplish a mathematically creative process. The conclusion of grouping pyramid and cube as well as cone and cylinder together can be interpreted as a shared meaning between the three persons. But both girls have different explanations: Sina argues with the same colour, Victoria with the same base area. But Victoria understands and bears her explanation as an extension of Sina’s one, she starts with “Yes because and ...”. So both explanations do not be mutually exclusive, but have equal rights.

SUMMARY AND PROSPECT

Understanding mathematical creativity in early childhood as a cooperative process, that emerges in the situational negotiations of meanings in social interactions the concept of the niche of the development of mathematical creativity has been introduced and demonstrated on an empirical case. It highlights the allocative and situational terms of a mathematically creative process as well as the individual mathematically creative action. Victoria and Sina have extended the mathematical content “geometrical solids and their properties” and “finding identical solids” to “build towers“, “size comparison” and “finding similar solids”. These changes in the mathematical content are linked to a changing of their social participation structure. The girls’ roles alter from *processor* to *initiator*. From a psychoanalytic point of view both girls show high cooperative strategies in supporting each other’s ideas, which may be linked to their attachment patterns. Also B’s role changing as response to the children’s needs seems to support the mathematical creative process of Victoria in grouping the mentioned solids together because of their same base area. This conclusion occurs in the polyadic interaction, when Victoria has to explain her grouping in a deep mathematically funded argumentation. It will be interesting to analyze how Victoria’s mathematically creative processes develop when she gets older and enters school.

Concerning children with insecure attachment patterns, the question arises how they behave in mathematical situations of play and exploration. How develop their mathematically creative processes and do they have different profiles of participation due to their attachment patterns? Additional analysis and niches may give some answers.

The niche of the development of mathematical creativity has not been completed by now. Additional analysis of scientific and folk pedagogy’s concepts about mathematical creativity and mathematics education arising in the social setting can give further insights about the conditions of the development of mathematically creative processes.

REFERENCES

Ainsworth, M. D., Blehar, M. C., Waters, E. & Wall, S. (1978). *Patterns of attachment*. Hillsdale, NJ: Erlbaum.

- Bateson, P., & Martin, P. (2013). *Play, playfulness, creativity and innovation*. Cambridge: Cambridge University Press.
- Bowlby J. (1969). *Attachment. Attachment and loss (Vol. 1)*. New York: Basic Books.
- Brandt, B. (2004). *Kinder als Lernende: Partizipationsspielräume und - profile im Klassenzimmer* [Children as learners. Leeway of participation and profile of participation in classroom]. Frankfurt a. M.: Peter Lang.
- Brandt, B., & Krummheuer, G. (2001). *Paraphrase und Traduktion: Partizipationstheoretische Elemente einer Interaktionstheorie des Mathematiklernens in der Grundschule* [Paraphrase and traduction]. Weinheim und Basel: Beltz Verlag.
- Bruner, J. (1986). *Actual minds: Possible worlds*. Cambridge, MA: Harvard University Press.
- Bruner, J. (1990): *Acts of meaning*. Cambridge, London: Harvard University Press.
- Carruthers, E., & Worthington, M. (2011). *Understanding children's mathematical graphics beginnings in play*. New York: Open University Press.
- Creasy, G., & Jarvis, P. (2003). Play in children. An attachment perspective. In O.N. Saracho & B. Spodek (Eds.), *Contemporary perspectives on play in early childhood education* (pp. 133-153). Charlotte, NC: Information Age Publishing.
- Crowell, J., & Feldman, S. (1988). Mother's internal models of relationships and children's behaviour and developmental status: A study of mother-infant-interaction. *Child Development*, 59, 1273-1285.
- Csikszentmihalyi, M. (1997). *Creativity: Flow and the psychology of discovery and invention*. New York: Harper Perennial.
- Ervynck, G. (1991): Mathematical creativity. Advanced mathematical thinking. In D. Tall (Ed.), *Advanced mathematical thinking* (pp. 42–53). Dordrecht: Kluwer.
- Finke, R. (1990): *Creative imagery. Discoveries and inventions in visualization*. Hillsdale, NJ: Lawrence Erlbaum.
- Green, J., Stanley, C., Smith, V., & Goldwyn, R. (2000). A new method of evaluating attachment representations in the young school age children: The manchester child attachment story task (MCAST), *Attachment and Human Development*, 2, 48-70.
- Guilford, J. P. (1967). *The nature of human intelligence*. New York: McGraw-Hill.
- Krummheuer, G. (2012). The “non-canonical” solution and the “improvisation” as conditions for early years mathematics learning processes: The concept of the “interactional niche in the development of mathematical thinking” (NMT). *Journal für Mathematik-Didaktik*, 33(2), 317–338. Doi: 10.1007/s13138-012-0040-z
- Krummheuer, G., Leuzinger-Bohleber, M., Müller-Kirchhof, M. Münz, M., & Vogel, R. (2013). Explaining the mathematical creativity of a young boy: An interdisciplinary venture between mathematics education and psychoanalysis.

Educational Studies in Mathematics, 84(2), 183-200. Doi: 10.1007/s10649-013-9505-3

- Krummheuer, G. & Schütte, M. (2013). *Das Wechseln zwischen mathematischen Inhaltsbereichen – Eine Kompetenz, die nicht in den Bildungsstandards steht* [The changing between mathematical domains – A competence that is not mentioned in the educational standards]. Manuscript submitted for publication.
- Lehmann, B. E. (1988). *Rationalität im Alltag? Zur Konstitution sinnhaften Handelns in der Perspektive interpretativer Soziologie* [Rationality in everyday life? Construction of meaningful acting in the perspective of interpretative sociology]. Münster, New York: Waxmann.
- Lithner, J. (2008). A research framework for creative and imitative reasoning. *Educational Studies in Mathematics*, 67, Issue 3, 255-276. Doi: 10.1007/s10649-007-9104-2
- Münz, M. (2014). *Non-canonical solutions in children-adult interactions: A case study of the emergence of mathematical creativity*. In C. Benz, B. Brandt, U. Kortenkamp, G. Krummheuer, S. Ladel, & R. Vogel (Eds.), *Early mathematics learning*. New York: Springer.
- Rogoff, B. (2003). *The cultural nature of human development*. Oxford: Oxford University Press.
- Sriraman, B. (2004): The characteristics of mathematical creativity. *The Mathematics Educator*, 14 (1), 19–34.
- Sternberg, R. J. & Lubart, T.I. (2000): The concept of creativity: Prospects and paradigms. In R. J. Sternberg (Ed.), *Handbook of creativity* (pp. 03-15). Cambridge, UK: Cambridge Univ. Press.
- Super, C. M., & Harkness, S. (1986). The developmental niche: a conceptualization at the interface of child and culture. *International Journal of Behavioural Development*, 9, 545–569.
- Torrance, E.P. (1974). *Torrance tests of creative thinking*. Bensenville, IL: Scholastic Testing Service.
- Toulmin, S. E. (1969): *The uses of argument*. Cambridge, UK: Cambridge Univ. Press.
- Van Oers, B. (2002). The mathematization of young children's language. In K. Gravenmeijer, R. Lehrer, B. van Oers, & L. Verschaffel (Eds.), *Symbolizing, modeling and tool use in mathematics education* (pp. 29-58). Dordrecht: Kluwer.
- Vogel, R. (2013). Mathematical situations of play and exploration. *Educational Studies in Mathematics*, 84(2), 209-226. Doi: 10.1007/s10649-013-9504-4.
- Vygotsky, L. (2004). Imagination and creativity in childhood. *Journal of Russian and East European Psychology*, 42(1), 7–97.
- Winnicott, D. W. (2012). *Playing and reality*. Retrieved from <http://www.ebilib.com>.

CREATIVE ADVANTAGES OF VISUAL SOLUTIONS TO SOME NON-ROUTINE MATHEMATICAL PROBLEMS

Norma Presmeg

Illinois State University

npresmeg@msn.com

Although affect is inevitably implicated in problem solving of all types, and is especially memorable in visual mental processing, this paper concentrates on the creative advantages of visual solutions to certain mathematical problems presented in words. After discussion of some theoretical constructs associated with creativity, examples of the power of visual processing are presented, drawn not only from papers written by members of the Algarve group taken from the Sub12 and Sub14 competitions, but also from my research on visualization over the last three decades. These examples illustrate also the richness of individual representations in several stages of problem solving—involving fluency, flexibility, and originality, which are often taken as core dimensions of creativity.

INTRODUCTION

The goal of this paper is to highlight the potential power and creativity of visual solutions to some non-routine problems drawn from the vast database of problem solutions of the Algarve Sub12 and Sub14 project, and from the problem bank I used in my own research on visualization over a period of more than three decades.

In reading eight of the many papers written about the mathematical problem solving web-based competitions organized and promoted by scholars at the University of Algarve, I was particularly impressed by the potential for variety in the outstanding collection of problems used in these competitions. I do not know the sources used by the organizers of the competitions in constructing this collection, but I was reminded of the *problem bank* of several hundred non-routine problems that I collected in the early 1980s. The purpose of my problems was different from the purpose of those used in the competitions: I needed a source for a “mathematical processing instrument” (MPI) that could be used to identify preference for visual thinking amongst senior high school students and their mathematics teachers. Thus one initial criterion for including a *word* problem (no pictures, since these might pre-empt a visual way of thinking) was that I should be able to solve the problem both visually and non-visually. The sources for my problems were varied, but many of them came from the rich collections made by Krutetskii (1976), and by Kordemsky (1981) in his *Moscow Puzzles*. After field-testing the instrument in two countries (England and South Africa), I followed Krutetskii in classifying the problems themselves as more or less visual, and according to their difficulty—based on analysis of the solutions presented by hundreds of students—and discarding those that were at the extremes of the scale. The result was an

instrument that consisted of Section A, 6 relatively easy problems; Section B, 12 problems of intermediate difficulty; and Section C, 6 problems that were more difficult. Sections A and B were used to determine the visual preferences of high school (and later, college) students, and Sections B and C were intended for their mathematics teachers. In this way, preferences of teachers and students could be compared, leading to classroom research that investigated the interplay of teaching and learning and the difficulties and affordances of visual thinking in mathematics over a whole school year (Presmeg, 1985). Creativity and affect were both important considerations in interpreting the results of this research over several decades (Presmeg & Balderas-Cañas, 2001). However, in this paper I shall concentrate on the creative aspects.

A powerful visual solution

In the account given by Jacinto, Carreira, and Amado (2011) of Leonor solving problem # 10, Cat and Mouse, the creative ingenuity of Leonor stands out. Here is the problem as it was given:

A hungry cat surprises a mouse. Immediately the mouse starts running and the cat follows in pursuit. When the mouse starts its escape, it has a lead of 88 mouse's little steps on the attacker. It turns out that 2 steps of the cat are equivalent, in distance, to 12 little steps of the mouse. Moreover, while the mouse takes 10 little steps, the cat takes 3 steps. How many steps must the cat take to catch the mouse? (p. 4)

Leonor devised a visual solution to the problem, which effectively synchronizes distance and time in a computer representation using color coding and 'chunking' of steps of a cat and mouse. The color coding enables her to impose a *time* element on the chunking of six little mouse steps for the *distance* of one cat step. The originality and power of Leonor's solution is evident: her visual representation serves both to *organize* the very complex distance and time relationships that are given, and to *enable a solution* that is elegant and certain. Before examining Leonor's solution, I tried to solve the problem myself, using algebraic equations—and I struggled to reconcile the two ratios given, those of 12 mouse steps being equivalent (in distance) to 2 cat steps, and of 10 mouse steps being equivalent (in time) to 3 cat steps. And the mouse had a head start of 88 little steps! Leonor's visual solution does not eliminate the need for reasoning: *logic* is certainly involved in her analysis of the 6:1 distance ratio, and in the superposition of a colourful 10:3 time ratio. This use of strong logic in an effective visual solution is consonant with the theoretical position I adopt (following Krutetskii, 1976) that strong logic is involved in all effective mathematical thinking, whether visual or non-visual: visualization and logic are not opposed, but are orthogonal in this model (Presmeg, 2006; Nardi, 2014). My further research through the decades showed again and again the effectiveness of alternating or combining visual modes and non-visual reasoning in solving mathematical problems at all levels, from elementary to college-level mathematics.

In this paper I present some solutions to problems on my MPI instrument that illustrate, similarly to Leonor's work, the power and elegance of visual creativity in this regard.

I illustrate also how certain problems (not necessarily from my MPI, since these would have been eliminated as being at the extreme of the scale) can be regarded as “visual” problems, because for these a non-visual solution is much more difficult—as Leonor’s solution to the cat-and-mouse problem shows. But first I discuss some theoretical elements concerning creativity, in the next section.

WHAT IS CREATIVITY?

Despite the perception that mathematical creativity is an important ingredient in furthering the discipline of mathematics, there is no generally accepted definition of what constitutes mathematical creativity (Sriraman & Lee, 2011). Hadamard’s (1945) influential account of mathematical creativity stressed the need for stages of absorbed attention and incubation before the *Aha!* moment that gives a sense of certainty that the way to a solution is clear. Even at this moment in mathematical problem solving, it is still necessary to verify that in fact a valid solution does result. Not specifically addressing mathematical creativity, Torrance (1972) considered the question of whether children can be taught to think creatively, and his influential tests for creative thinking using words and pictures (1966) set a means by which many researchers judged work to be creative according to its fluency, flexibility, originality, and richness of elaboration. In mathematics education, several researchers have elaborated on this early work (Yuan & Sriraman, 2011, Presmeg, 1981). Yuan conducted interesting doctoral research in China and the USA, using the theoretical lens of Guilford’s *Structure of Intellect* model, and Torrance’s tests. It does not seem necessary to limit creativity to divergent thinking (as opposed to convergent thinking) as some have done (e.g., de Bono, 1970). However, novelty and usefulness are considered to be key elements by some researchers (Yuan & Sriraman, 2011), resonating with the requirement of originality in Torrance’s formulation. It seems clear to me that solutions such as that of Leonor, discussed in the first section, contain these essential elements of creative thinking in mathematics, and her solution can serve as a paradigm case.

CREATIVE MATHEMATICAL PROBLEM SOLVING

It seems to me that the *openness* of acceptable means of arriving at a correct solution in both the Qualifying and the Competition stages of the Sub12 and Sub14 competitions should be a strong catalyst for creative thinking in these young learners. And indeed, many of the solutions presented in the group’s publications do give evidence of such thinking. For instance, the solutions of four grade 8 students to the problem about the three daughters of Mr. José, Joana, Josefina, and Júlia, are both novel and useful, using arithmetic and algebraic means or a combination of the two (Amado, Carreira, Nobre, & Ponte, 2010). The problem statement is as follows:

Mr José has three daughters who love to eat sweets: Joana, Josefina, and Júlia. In the summer as they went to the beach they started to worry about their figure. So they decided to go on a diet and the three of them regularly weighed on a big scale their father keeps in his store. Before starting on diet they stepped on the scale in pairs. Joana and Josefina both

weighed 132 kg. Josefina and Júlia both weighed 151 kg. Júlia and Joana both weighed 137 kg. How much did each of the sisters weigh? (Vol. 2, p. 140)

Solutions to such problems do not always involve visual means of representation. Amado et al. (2010) report that 40% of the students solved the problem correctly, and that arithmetic solution were those most commonly used. The purpose of my MPI instrument was to investigate the *mathematical visuality* (MV) of individuals—defined as *preference for visual thinking*—when the solution methods available provide a reasonable choice.

It is useful to define visual means of solution as including not only inscriptions in the form of pictures, but also more abstract spatial depictions involving arrows, charts, and patterns (Presmeg, 2006). In this paper I confine my examples to those involving visual representations, because I hope to show the power of visual creativity in solving non-routine mathematical problems. In my research I asked participants to tell me about their mental visual imagery as well, and often this imagery was vivid and striking, but that is another story.

Problems that are of a ‘visual’ nature

As explained, such problems were not included in my instrument for measuring preference for visual thinking in mathematical problem solving, in which the purpose was to see how individuals approached problems when both visual and non-visual solutions were approximately equally facilitative of finding a solution. However, it is instructive to consider how potent visuality can be in solution of problems that may be classified as ‘visual’, such as the following.

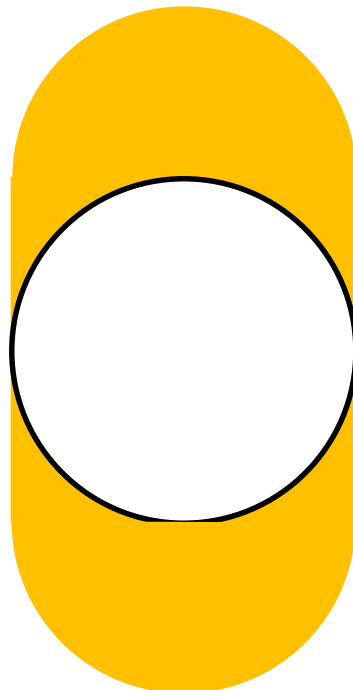

Figure 1. The altar window, showing construction of the gilded area.

This classic problem by Wertheimer (1966) concerns a circular Altar Window. The area around the window is being gilded by workmen, as in Fig. 1, surrounding the window with a square and two semicircles as shown. The problem is to work out the size of the gilded area, in terms of the diameter of the circle.

People who attempt a piecewise solution using formulae may find this problem to be difficult, particularly if the construction square is not shown. However, a dynamic visual solution is to slide the two semicircles mentally into the centre circle. Then it is almost trivially apparent that the gilded area is the same as the area of the square, that is, the diameter squared. What makes such a solution creative is that it may be necessary to break the mental set that suggests formulae when the word “area” is presented, in order for a more fruitful visual solution method to become apparent.

It is notable that as in the Altar Window example, *dynamic* or moving inscriptions are often powerfully effective in solving non-routine mathematical problems (Presmeg, 2006)—and the affordances of technology now are likely to enhance this aspect of visualization, as recognized by the Algarve group, and as illustrated in research using various forms of dynamic geometry software (e.g., Yu, Barrett, & Presmeg, 2009).

Problems that are neither ‘visual’ nor ‘non-visual’

In order to allow preference for visual methods to become apparent, the MPI had to consist of problems that had the potential for visual and nonvisual solutions. In many cases, visual solutions manifested creativity. Sometimes metaphors were implicated in such visual solutions (Presmeg, 1992, 1998), as in the following problem, C-3 from the MPI, in which Mr. Green (pseudonym of a college student) used the metaphor of a clockface in his solution.

C-3. A boy walks from home to school in 30 minutes, and his brother takes 40 minutes. His brother left 5 minutes before he did. In how many minutes will he overtake his brother?

Visual symmetry was an important element in Mr. Green’s solution (Fig. 2). This symmetry immediately yielded the solution that the boy would overtake his brother in 15 minutes.

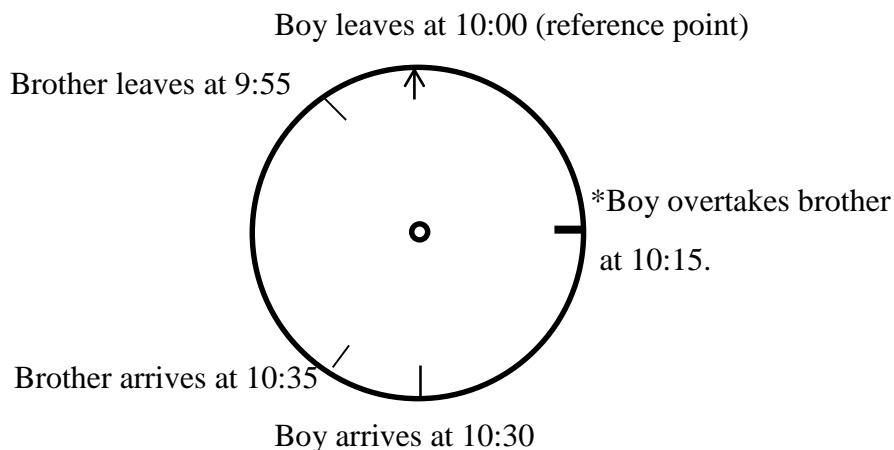

Figure 2. A unified ‘clock’ image for problem C-3, using Mr. Green’s metaphor.

A solution by a different student was as follows:

Because the boy takes 30 minutes and his brother 40 minutes, to walk the same distance, the ratio of their times for equal distances is 3:4. Consider the unit of distance for which the boy takes 3 minutes and his brother 4 minutes.

	<u>1</u>	<u>1</u>	<u>1</u>	<u>1</u>	<u>1</u>	<u>1</u>
Boy's time:	0	3	6	9	12	15
Brother's time:	-5	-1	3	7	11	15

Thus the boy will overtake his brother in 15 minutes.

Logic is clearly evident in both of these solutions. However, different elements of creativity are involved, although both manifest originality: symmetry is less evident in the second solution, which is nevertheless also elegant and fluent.

In non-routine problem solving, the intricacies of coordinating distance and time often involve challenges for students, as recognized by Carreira (2012), and as overcome so brilliantly by Leonor, as illustrated earlier (Jacinto et al., 2011). I present problem C-6 from the MPI (one of Kordemsky's *Moscow Puzzles*), as another illustration of the power of visual thinking in this regard.

C-6. A train passes a telegraph pole in $\frac{1}{4}$ minute and in $\frac{3}{4}$ minute it passes completely through a tunnel 540 metres long. What are the train's speed in metres per minute and its length in metres?

This problem elicits non-visual problem solving means for many people: algebraic equations are then a first resort, and the solution can be attained, but it is complicated. An elegant and creative visual solution is to imagine the telegraph pole placed at the entrance to the tunnel, as in Figure 3.

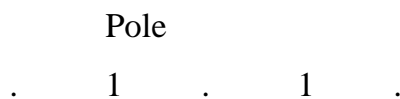

The first segment of the journey is where the train is before it enters the tunnel. Each segment takes the train a quarter minute. It takes the front of the train half a minute to go the length of the tunnel. Thus the speed of the train is $540 \times 2 = 1080$ metres/minute, and the length of the train is half the length of the tunnel, i.e., 270 metres.

Figure 3. A creative visual solution for C-6, the Train in Tunnel problem.

Some people use the basic thinking illustrated in Fig. 3, but they actually *draw* the train, usually in the first segment before it enters the tunnel, complete with engine, carriages, and smoke emerging from the stack! Such an iconic illustration adds nothing to the problem solution, but it has an aesthetic function. Such drawings were also identified in the solutions of problems in the Sub12 and Sub14 competitions, as in the Cages and Parrots problem (Jacinto & Carreira, 2012); and Jacinto, Amado and Carreira (2009) recognized the nature of such illustrations. This phenomenon also

resonates with the advantages of *pattern* imagery over *concrete* imagery, which was a striking result of my research (Presmeg, 2006). Pattern imagery strips away unnecessary details, as in the inscription in Fig. 3: it is unnecessary to draw the train! However, as Carreira points out (email communication), the affordances of technology may blur the distinction between concrete and pattern imagery. In solving the Train in Tunnel problem, Carreira brilliantly copied from the internet, images of a train, a telegraph pole, and a bridge (a tunnel was not available), and made a collage that adapted these to correspond exactly to the solution in Fig. 3. Her solution was clearly a concrete picture of the situation. But there is a pattern-like aspect. As she wrote in her email message, “the situation has itself a pattern.” This is one further instance of how the affordances of technology change conclusions from earlier research. Yu, Barrett, and Presmeg (2009) reported that use of *Shapemaker* software with middle grades students reversed the order of the van Hiele stages in learning the properties of geometric shapes.

One more problem from section C of the MPI illustrates the contrast between visual and nonvisual solutions.

C-4. An older brother said to a younger, “Give me eight walnuts, then I will have twice as many as you do.” But the younger brother said to the older one, “You give me eight walnuts, then we will have an equal number.” How many walnuts did each have?

C-4. Solution 1: I used symbols and equations, e.g.,

Let the younger brother have x walnuts and the older, y walnuts.

$$y + 8 = 2(x - 8)$$

and $y - 8 = x + 8.$

Solve simultaneously: $x = 40$ and $y = 56.$

The younger brother has 40 walnuts and the older 56 walnuts.

C-4. Solution 2: I drew a diagram to represent the number of walnuts.

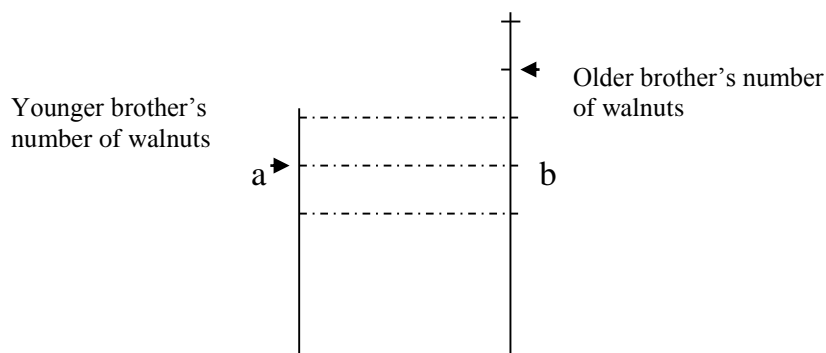

From the conditions of the problem, the top half of line b is divided into 4 equal parts, each representing 8 walnuts. Thus 7 of these parts represents the older brother’s number of walnuts and 5 parts represents the younger brother’s. Thus the younger brother had 40 and the older brother 56 walnuts.

It is apparent that the visual solution to the problem in this case, Solution 2, is conceptually complex. In fact in this instance the easier solution for many people would be Solution 1. This problem illustrates that it is not always the case that a visual solution provides an easier method, although for some problems that is the case. Nevertheless, Solution 2 for the Walnuts problem is certainly creative, and it was the preferred method for many people.

CONCLUSION

How prevalent is the preference for visual thinking in mathematical problem solving? Contrary to the conclusion of Eisenberg (1994) that students are reluctant to visualize in mathematics, my research provided ample evidence (Presmeg, 2006) that for some students—the visualizers—there is no other way! However, it is clear that sociocultural considerations, including the *value* placed on this mode of thinking in classrooms, may hinder students from using or expressing their preferred mode. This aspect points to the advantage of accepting and valuing all attempts at solution, irrespective of the mode, that is evident in the Sub12 and Sub14 competitions.

The requirement in these competitions that students should explain their thinking in solving the Sub12 and Sub14 problems gives the organizers a window into creative elements in the students' thinking and presentation of their work. Considering the core elements of fluency, flexibility, originality, and elaboration, it is apparent that *fluency* and *elaboration* would be manifest in creative solutions spelled out in these competitions. Because only one method of solution is required in the competitions, it is more difficult to judge *flexibility*. However, despite the fact that students could work collaboratively and get help from various sources in the Qualifying round, it seems reasonable to expect that *originality* (even for a group solution) could be apparent. It is hard to imagine that a majority of students would come up with the solution to the Cat and Mouse puzzle submitted by Leonor! This solution certainly appears to manifest originality. Thus the potential for identifying creativity is high in these competitions. In particular, I would be interested to know how prevalent visually creative solutions were.

I elaborate on the identification of various preferences for visuality in the next section.

Preference for visual representations when there is a choice

In the MPI, individuals first solved the 18 problems (either 6 from A and 12 from B—students, or 12 from B and 6 from C—teachers) in any way that was comfortable for them, and after they had completed their solutions, they selected from a questionnaire the solution that was closest to theirs for each problem. For problem C-3 (the boy and his brother going to school), for instance, the following were the choices.

C-3. Solution 1: I drew a diagram representing the times:

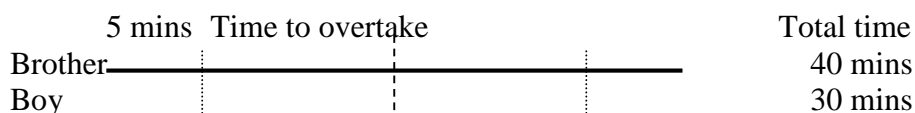

From the diagram: the boy will arrive at school 5 minutes before his brother; thus the two halves of the figure must be symmetrical, so he will overtake his brother halfway, i.e., after 15 minutes.

C-3. Solution 2: As in solution 1, but I imagined the diagram.

C-3. Solution 3: I used symbols and equations, e.g.,

Let distance to school be d units, and let the boy overtake his brother in x minutes.

Then his brother has walked for $(x+5)$ minutes.

The boy's speed is $\frac{d}{30}$ units per minute, and his brother's is $\frac{d}{40}$.

When he overtakes, they have gone the same distance.

Thus $\frac{d}{30}x = \frac{d}{40}(x+5)$, and thus $x = 15$.

The boy overtakes his brother in 15 minutes.

C-3. Solution 4: I solved this problem by calculating their times to reach the halfway point.

It takes the boy 15 minutes and his brother 20 minutes. But the brother left 5 minutes earlier; thus they will reach the halfway point together. The boy overtakes his brother in 15 minutes.

C-3. Solution 5: I drew a graph:

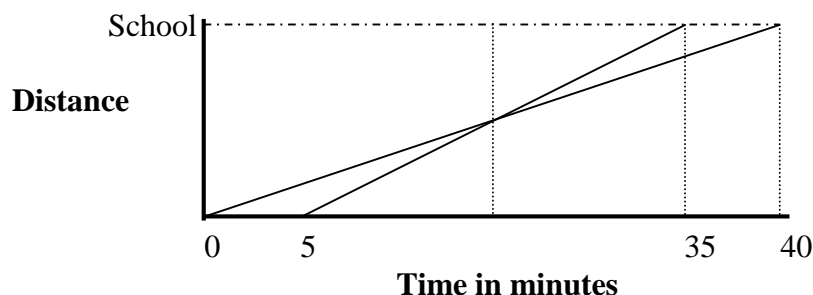

By symmetry the graphs intersect midway.

Thus the boy overtook his brother in 15 minutes.

Solutions 1, 2 and 5 count as visual solutions for this problem, and these would be scored as 2 points towards a Mathematical Visuality score (MV). Solutions 3 and 4 would score 0, and there was the option of checking a box “none of these”, which would score 1. Thus for the 18 problems, the possible MV total is 36 points. It was found through multiple administrations of the MPI in England, South Africa, Sweden, and the USA, that MV scores for the general population follow a standard Gaussian distribution. For most people, it depends on the problem whether or not they employ visual means; however, there are visualizers who always, or almost always, need to work visually. And at the other end of the scale, some people seldom or never have such a need. It is not that visualization is necessary in order for a solution to be creative: many of the solutions involving numbers and algebraic thinking described by Amado et al. (2010) manifest characteristics of creativity. However, when an elegant visual solution shortcuts the difficulties of using equations and numerical methods—as in

Leonor's solution at the beginning of this paper—then the potential power and creativity of visual thinking are revealed.

Using the MPI provided *quantitative* data that showed no significant difference between the MV scores of boys and girls in grade 11, near the top of the high school. However, there was a significant difference between the scores of students and their mathematics teachers: the students needed more visual methods than did their teachers. However, there was only a weak correlation (Spearman's $\rho = 0.4$) between the teachers' MV scores and the visuality of their *teaching* (TV scores—obtained by triangulation of observations by researcher and students, and teachers' self-report). A good teacher knows the needs of the students.

The use of non-parametric statistical methods was offset by the rich details provided also by *qualitative* research. The qualitative interview methodology of my research over many decades revealed also different kinds of visualization in problem solving. What I called *pattern imagery* was far more effective in many cases than *concrete imagery*—corresponding roughly to the spatial and iconic types identified by Carreira (2012). Pictures are not always useful: in fact there is evidence in my data that some kinds of pictures, or too much attention to unproductive aspects, may in fact hinder problem solving (Presmeg, 2006). But I agree totally with Carreira (2012) that when imagery and visual inscriptions are used with fluency and flexibility—enhanced by the affordances of technology—they are powerfully creative modes of problem solving.

A final word

In this paper I have made no distinction amongst the various stages of problem solving. These stages might be classified according to Polya's (1954) well-known stages, namely, understanding the problem, constructing a plan, carrying out the plan, and checking the solution. Certainly it is evident in the problems presented in this paper, as well as others described by members of the Algarve group, that a visual inscription in the form of a diagram, a chart, or anything that depicts a spatial layout can be useful to students in understanding and setting out the conditions of a problem. And often such activity leads to the construction of a plan for solving the problem, or in some cases directly to the solution itself, as in Mr. Green's clockface summary of the conditions of the Boys Going to School problem, or indeed in Leonor's solution of the Cat and Mouse problem. If one were investigating the affect associated with each stage of problem solving, breaking down solutions into stages is productive (as reported by Presmeg & Baldero-Cañas, 2001). Such research is enriched by qualitative interview methodology. However, with the rich database provided by the Sub12 and Sub14 competitions, if creativity is the focus of the research, it would appear that it is unnecessary to separate the process of finding a solution into stages, which in any case are reflexively related and collapsed in many instances, particularly if the solution process is a visual one.

REFERENCES

- Amado, N., Carreira, S., Nobre, S., & Ponte, J. P. (2010). Representations in solving a word problem: The informal development of formal methods. In M. F. Pinto & T. F. Kawasaki, (Eds.), *Proceedings of the 34th Conference of the International Group for the Psychology of Mathematics Education* (Vol. 2, pp. 137-144). Belo Horizonte, Brazil: PME.
- Carreira, S. (2012). *Mathematical problem solving beyond school: Digital tools and students' mathematical representations*. Paper presented at the 12th International Congress on Mathematical Education, 8-15 July, 2102, Seoul.
- De Bono, E. (1970). *Lateral thinking: A textbook of creativity*. Middlesex: Pelican.
- Hadamard, J. (1945). *The psychology of invention in the mathematical field*. Princeton, NJ: Princeton University Press.
- Jacinto, H., Amado, N., & Carreira, S. (2009). Internet and mathematical activity within the frame of "Sub 14". In V. Durand-Guerrier, S. Soury-Lavergne, & F. Arzarello (Eds.), *Proceedings of the Sixth Congress of the European Society for Research in Mathematics Education* (pp. 1221-1230). Lyon, France: Institut National de Recherche Pédagogique.
- Jacinto, H., & Carreira, S. (2012). *Problem solving in and beyond the classroom: Perspectives and products from participants in a web-based mathematical competition*. Paper presented at the 12th International Congress on Mathematical Education, 8-15 July, 2102, Seoul, South Korea.
- Jacinto, H., Carreira, S., & Amado, N. (2011). Home technologies: How do they shape beyond-school mathematical problem solving activity. *Proceedings of the 10th International Congress for Technology in Mathematics Teaching*. Portsmouth, UK: July, 2011.
- Kordemsky, B. A. (1981). *The Moscow puzzles*. Middlesex, England: Penguin.
- Krutetskii, V. A. (1976). *The psychology of mathematical abilities in schoolchildren*. Chicago, IL: University of Chicago Press.
- Nardi, E. (2014). Reflections on visualization in mathematics and in mathematics education. In M. Fried (Ed.), *Mathematics and mathematics education: Searching for common ground*. New York: Springer.
- Polya, G. (1954). *Mathematics and plausible reasoning*. Putnam: Princeton University Press.
- Presmeg, N. C. (1981). *Parallel threads in the development of Albert Einstein's thought and current ideas on creativity: What are the implications for the teaching of high school mathematics?* Unpublished M.Ed. dissertation, University of Natal, South Africa.

- Presmeg, N. C. (1985). *The role of visually mediated processes in high school mathematics: A classroom investigation*. Unpublished Ph.D. dissertation, University of Cambridge, UK.
- Presmeg, N. C. (1992). Prototypes, metaphors, metonymies and imaginative rationality in high school mathematics. *Educational Studies in Mathematics*, 23(6), 595-610.
- Presmeg, N. C. (1998). Metaphoric and metonymic signification in mathematics. *Journal of Mathematical Behavior*, 17(1), 25-32.
- Presmeg, N. C. (2006). Research on visualization in learning and teaching mathematics: Emergence from psychology. In A. Gutierrez & P. Boero (Eds.), *Handbook of research on the psychology of mathematics education* (pp. 205-235). Rotterdam: Sense Publishers.
- Presmeg, N. C. & Balderas-Cañas, P. (2001). Visualization and affect in nonroutine problem solving. *Mathematical Thinking and Learning*, 3(4), 289-313.
- Sriraman, B., & Lee, K. H. (2011). *The elements of creativity and giftedness in education*. Rotterdam: Sense Publishers.
- Torrance, E. P. (1966). *Thinking creatively with words, A and B; Thinking creatively with pictures, A and B*. Princeton, NJ: Personnel Press.
- Torrance, E. P. (1972). Can we teach children to think creatively? *The Journal of Creative Behavior*, 6(2), 114-143.
- Wertheimer, M. (1966). *Productive thinking*. London: Tavistock Publications.
- Yuan, X, & Sriraman, B. (2011). An exploratory study of relationships between students' creativity and mathematical problem-posing abilities: Comparing Chinese and U.S. students. In B. Sriraman & K. H. Lee (Eds.), *The elements of creativity and giftedness in education* (pp. 5-28). Rotterdam: Sense Publishers.
- Yu, P., Barrett, J. & Presmeg, N. (2009). Prototypes and categorical reasoning: A perspective to explain how children learn about interactive geometry objects. In T. Craine (Ed.), *Understanding geometry for a changing world*, 71st NCTM Yearbook (pp. 109-125). Reston, VA: NCTM.

THE BORROWERS: USING TRANSPORTATION, ADDRESSES, AND PARALELEPÍPEDOS TO PROMPT CREATIVITY USING ETHNOMODELING

Daniel Clark Orey, Milton Rosa

Centro de Educação Aberta e a Distância, Universidade Federal de Ouro Preto,
Minas Gerais, Brasil

oreydc@cead.ufop.br, milton@cead.ufop.br

It is our pleasure to share with readers a bit about our journey and our developing perspective in relation to the creative potential we have encountered in California, New Mexico, Nepal, Guatemala, and Brasil in relation to ethnomathematics and mathematical modeling and distance education. We conclude this discussion with a few brief examples of how ethnomodeling works in Brasil.

INTRODUCTION

The starting point of this discussion is related to the question, what does it take to make a mathematical mind? By answering this question, it is necessary to outline factors regarding: a) Number sense; b) Numerical ability; c) Algorithmic ability; d) Ability to handle abstraction; e) A sense of cause and effect; f) Ability to construct and follow a causal chain of facts or events; g) Logical reasoning ability; h) Relational reasoning ability; i) Spatial reasoning ability (Devlin, 2000).

We have encountered these abilities in a diversity of cultural manifestations. For example, as a teacher in Guatemala in the early 80's, Professor Orey first encountered mathematics in the context of culture. While purchasing an item in a highland Maya market, he bartered with a woman who took a hand-held calculator from inside her huipil[1]. Neither of them could speak the other's language, so she quickly punched in the price she wanted and handed it back to him. Shaking his head, he then entered a new price and handed it back to her. This process continued until both were met with satisfaction. It was not until a few hours later while returning home on the bus that Orey asked himself: *What just happened?*

Over the years he has become increasingly interested in how diverse people incorporate new ideas and technologies; in novel and creative ways, and how these interactions, often enabled by technologies, are increasingly affecting all of our thinking and learning processes. In this regard, we need to take special effort to open our eyes to the dynamic histories and technological sophistication of indigenous cultures (Eglash et. al, 2006).

Mathematical thinking is influenced by the diversity of human environments and their elements such as language, religion, mores, economics, and social-political activities. These same forces influence and encourage creativity. Historically, human beings have

developed logical processes related to quantification, measurement, and modeling in order to understand and explain their socio-cultural-historical contexts (Rosa & Orey, 2010). These processes allow each cultural group to develop its own way to *mathematize*[2] their own realities.

According to this perspective, the purpose of this paper is to provide a discussion on ethnomodeling, which aims to show through a series of examples how mathematics can be understood and used as way of translating mathematical practices in diverse cultural contexts.

However, before discussing our work in Ouro Preto, a brief discussion of *ethnomathematics* and *ethnomodeling* is necessary in order to assist in contextualizing aspects of mathematical creativity, which may be described as a multifaceted construct involving both “divergent and convergent thinking, problem finding and problem solving, self-expression, intrinsic motivation, a questioning attitude, and self-confidence” (Runco, 1993, p. ix). In this direction, students need to see how mathematics is developed and realize that creative individuals help the evolution of mathematical knowledge.

ETHNOMATHEMATICS

Ethnomathematics is the application of mathematical ideas and practices to problems that confronted people in the past or are encountered in present day culture (D’Ambrosio, 2001). Much of what we call *modern mathematics* came about as diverse cultural groups sought to resolve unique problems such as commerce, art, religion, exploration, colonization and communications, along with the construction of railroads, census data, space travel, and other problems-solving techniques that arose from particular communities. For example, the Mayans invented the number zero and the positional value that are often attributed to the Hindus around the 9th century. These concepts were transmitted to the Arabs from the Hindus by means of exchanges of commercial activities (Rosa & Orey, 2005).

Cultural variables have strongly influenced how students how came to understand their world and interpret their own and others experiences (D’Ambrosio, 1990). In attempting to create and integrate mathematical materials related to different cultures and that draw on students’ own experiences in an instructional mathematics curriculum, it is possible to apply ethnomathematical strategies in teaching and learning mathematics. These strategies include, but are not limited to the historical development of mathematics in different cultures, which means that:

(...) people in different cultures which use mathematics (e.g. an African-American biologist, an Asian-American athlete). Mathematical applications can be made in cultural contexts (e.g. using fractions in food recipes from different cultures). Social issues can be addressed via mathematics applications (e.g. use statistics to analyze demographic data) (Scott, 1992, p. 3-4).

The challenge that many communities face today is in determining how to shape a modernized, national culture, which integrates selected aspects and where its diverse ideas coexist in an often delicate balance with those of westernized science. Increased cultural, ethnic, and racial diversity while not homogenizing the whole, providing both opportunities for, as well as challenges to, societies and institutions, with many questions related to schooling forming an integral part of this question. Indeed the most creative dynamic and productive societies do this well (Florida, 2004).

ETHNOMATHEMATICS AS A PROGRAM

The inclusion of moral consequences into mathematical-scientific thinking, mathematical ideas, procedures, and experiences from different cultures around the world is vital. The acknowledgment of contributions that individuals from diverse cultural groups make to mathematical understanding, the recognition and identification of diverse practices of a mathematical nature in varied cultural procedural contexts, and the link between academic mathematics and student experiences should all become central ingredients to a complete study of mathematics.

This is one of the most important objectives of an ethnomathematics perspective in mathematics curriculum development. Within this context, ethnomathematics can be described as:

The prefix *ethno* is today accepted as a very broad term that refers to the sociocultural context, and therefore includes language, jargon, and codes of behavior, myths, and symbols. The derivation of *mathema* is difficult, but tends to mean to explain, to know, to understand, and to do activities such as ciphering, measuring, classifying, ordering, inferring, and modeling. The suffix *tics* is derived from *techné*, and has the same root as art and technique. In this case, *ethno* refers to groups that are identified by cultural traditions, codes, symbols, myths and specific ways used to reason and to infer (D'Ambrosio, 1990, p. 81).

In this regard, ethnomathematics forms the intersection between cultural anthropology and institutional mathematics that uses mathematical modeling to solve real-world problems in order to translate them into modern mathematical language systems. In so doing, mathematical modeling is a creative tool, which provides a translation from indigenous knowledge systems to Western mathematics. This perspective is crucial in giving minority students a sense of cultural ownership of mathematics, rather than a mere gesture toward inclusiveness (Eglash et. al, 2006).

An essential aspect of the program includes an ongoing critical analysis of the generation and production of mathematical knowledge as well as the intellectual processes of this production (Rosa & Orey, 2010). This program seeks to explain, understand, and comprehend mathematical procedures, techniques and abilities through a deeper investigation and critical analyses of students' own customs and cultures. In Brasil, the use of Bakairi body painting in Bakairi schools facilitates the comprehension of spatial relations such as form, texture, and symmetry; which are

excellent for the construction and the systematization of geometrical knowledge by allowing students to experience academic mathematical language through a cultural lens (Rosa, 2005).

In this context, the use of artifacts from cultural groups in educational settings that can raise students' self-confidence, enhance and stimulate their creativity, and promote their cultural dignity (D'Ambrosio, 2001). The use of ethnomathematics as pedagogical action restores a sense of enjoyment or engagement and can enhance creativity in doing of mathematics.

ETHNOMODELING

Studies conducted by Urton (1997) and Orey (2000) have shown us “sophisticated mathematical ideas and practices that include geometric principles in craft work, architectural concepts, and practices in the activities and artifacts of many indigenous, local, and vernacular cultures” (Eglash et. al, 2006, p. 347). Mathematical concepts related to a variety of mathematical procedures and cultural artifacts form part of the numeric relations found in universal actions of measuring, calculation, games, divination, navigation, astronomy, and modeling (Eglash et. al, 2006).

The term *translation* is used here to describe the process of modeling local cultural systems, which may have a Western academic mathematical representation (Eglash et. al, 2006; Orey & Rosa, 2006). Indigenous designs may be simply analysed as forms and the applications of symmetrical classifications from crystallography to indigenous textile patterns (Eglash et. al, 2006). On the other hand, ethnomathematics uses modeling to establish the relations found between local conceptual frameworks and mathematical ideas embedded in numerous designs. We define this relationship as *ethnomodeling* because “the act of translation is more like mathematical modeling” (Eglash et. al, 2006, p. 348).

In some cases, translation into Western-academic mathematics is “direct and simple such as that found in counting systems and calendars” (Eglash et. al, 2006, p. 347). For example, the mathematical knowledge that lace makers in the northeast of Brasil use to make geometric lace patterns, (Figure 1) have mathematical concepts that are not associated with traditional geometrical principles, which may be modeled through the techniques of ethnomodeling.

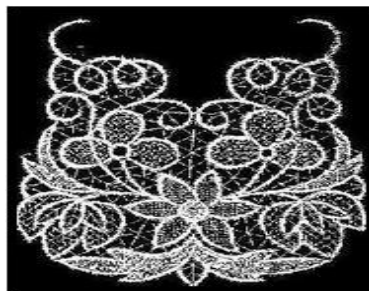

Figure 1. Geometric lace patterns.

Ethnomodeling takes into consideration diverse processes that help in the construction and development of scientific and mathematical knowledge, which includes collectivity, and overall sense of and value for creative invention. It may be considered as the intersection region of cultural anthropology, ethnomathematics, and mathematical modeling (Figure 2).

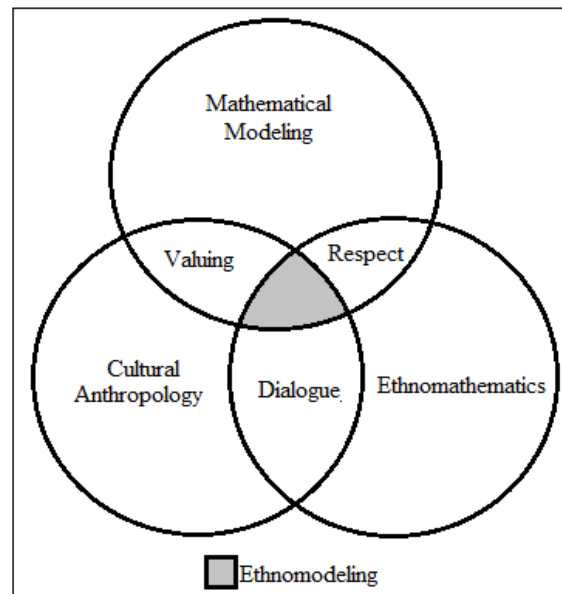

Figure 2. Ethnomodeling as the intersection region of three knowledge fields.

The processes and production of scientific and mathematical ideas, procedures, and practices operate as a register of the interpretative singularities that regard possibilities for symbolic constructions of the knowledge in different cultural groups. In this context, mathematics is not a universal language after all, because its principles, concepts, and foundations are not always the same around the world. By using ethnomodeling as a tool towards pedagogical action of the ethnomathematics program, students can be shown to learn how to find and work with authentic situations and real-life problems (Rosa & Orey, 2010, p. 60).

GENERAL ASSERTION

Ethnomathematics is a contemporary pedagogical trend in education (Scientific American-Brasil, 2005). The world's economy is globalized, yet, traditional mathematics curricula neglects, indeed often rejects contributions made by non-dominant cultures. An ethnomathematical perspective offers new and expanded definitions of a given society's particular scientific contributions.

Pedagogically, ethnomathematics allows school mathematics to be seen “as the process of inducting young people into mathematical aspects of their culture” (Gilmer, 1990, p. 4). An ethnomathematics perspective reshapes cultural identity in a positive way by requiring the inclusion of a greater representation of practices and problems of a student's own community (D'Ambrosio, 1995).

Ethnomathematics helps both educators and students alike to understand mathematics in the context of ideas, procedures, and practices used in their day-to-day life. It further encourages an understanding of professional practitioners, workers, and academic or school mathematics. Such depth is accomplished by taking into account historical evolution and the recognition of natural, social and cultural factors that shape human development (D'Ambrosio, 2001).

SOME PRACTICAL IDEAS AND EXAMPLES

So, how to go about doing this? How does this relate to creativity and mathematics? Toliver (2008) has for years offered an interesting tool she named a *Math Trail* by which we considered connecting our thinking to the mathematics found in the cultural context of a neighborhood school. She has said that in this activity, she saw a way to get her students working with each other, in a way to have them become active learners, and to increase their respect for their own community. Together with mathematical modeling we have used this perspective in Nepal, Guatemala, United States, and Brasil. We have shared here examples that engendered a great deal of creativity in groups of learners.

An exploration of Addresses in Ouro Preto

In 2005, Prof. Orey was invited to participate as a visiting professor with the mathematics education group at UFOP. During that time he began working with a group of elementary school children attending one of the municipal schools in Ouro Preto, Minas Gerais, Brazil. That *pilot study* became the basis for the Ouro Preto Math Trail[3]. Prof. Orey visited the school and worked with the kids over a period of 8 months.



Figure 3. Students doing research in front of the school in Ouro Preto.

When a group of nine year old students were asked why the first house number on Rua Alvarenga began with a number 7 (Figure 3), automatically, the responses were “it is 7 meters from the bridge”. Upon exploration and discussion we found that it was not 7 meters.



Figure 4. Number 7 on Rua Alvarenga.

After some research we found that measurements in the historic center of Ouro Preto were once based on the old imperial units such as *barras*[4]. We took the distance from the end of the bridge to the door divided it by seven and found it closely resembled the *barra unit* and then realized that all the address were showing distances along the street. For example, my apartment building was at 130 Rua Alvarenga (130 *barras* from the beginning of the street).

Kids from a rural *aldeia*[5] *Coelhos*[6], after visiting the *Ouro Preto Math Trail*, studied their own street and presented a plan to the mayor's office. The result was that the houses in *aldeia* were renumbered! This approach allowed kids the opportunity to learn and use mathematics in order to make either a transformation or contribution to the community. The idea that learning mathematics and giving back to one's community at the same time is motivating because it gives all us reason for hope.

How many Paralelepípedos [7] are on the Rua Alvarenga?

This was just one of a few activities that students developed in Ouro Preto. The activities gave a sense of importance and value to Ouro Preto, a *World Cultural Heritage* site that did not exist among the students of their university town.

College students in the specialization program in Prof. Orey's mathematical modeling class at the Universidade Federal de Ouro Preto were enlisted to create final projects related to Rua Alvarenga. The students divided themselves into a number of groups and asked to develop and solve problems related to Rua Alvarenga. One group developed a number of models that estimated the number of *paralelepípedos* (Figure 5).



Figure 5. Paralelepípedos on the Rua Alvarenga.

Transportation[8], Modeling, and Moodle[9]

In June of 2013, millions of Brazilians went to the streets to protest corruption; the movement was spurred on by tremendous amounts of money spent on stadiums for the FIFA World Cup in 2014 while social services, health care, and education have suffered. The straw that broke the camel's back so to speak was brought on by a sudden rise in transportation (mostly bus fares) across the country (Langlois, 2013; Orey, 2013).

During this same time, Prof. Orey was teaching his online course entitled *Seminar in Mathematical Modeling* with 110 students enrolled across 2 states in 10 very diverse educational centers named *polos* [10]. Normally, a good portion of the course is devoted to forming groups and having the students find their own themes, but this semester everyone was encouraged to select *transportation* as a theme. Groups of students in all polos produced models regarding to the proposed theme. Both students and professor was to be courageous to use the moment and not be afraid of taking aspects of day to day events found in our daily lives and use these opportunities to teach, learn, and communicate mathematical findings.

Because this seminar is a long-distance offering, each group recorded a 10 minute video and placed it on YouTube and shared the link on the class forum. A PowerPoint and a short paper used in the presentation describing their findings were shared with the class, professor and tutors.

Each presentation shared a brief introduction on the development of the submitted work; information they gained through interviews with citizens and public transport users in their respective cities; questions related to the situations presented in the interviews; mathematical models built upon the data researched; possible solutions to the problems outlined, and conclusions and reflections.

FINAL CONSIDERATIONS, THOUGHTS AND QUESTIONS

If one borrows something from someone, then one is less than interested in truly incorporating it (D'Ambrosio, personal communication, email, January 23, 2008). Borrowing suggests that one wants to borrow it to do something, as in collecting something *exotic* to place in a museum shelf, or like a selection of food at any shopping mall. The act of borrowing is only important for a particular moment and does not serve for the present when diverse elements collide, live, and create new foods, music, science and of course mathematics as is happening in numerous locations in the Americas.

When we *borrow*, we are acquiring objects or ideas with less thought or any sense of mindfulness to where they come from or how they came to be. Borrowing is often less interested in *knowing* the culture of the other. In a communication, D'Ambrosio (personal communication, email, January 23, 2008) shared with me that if culture A meets culture B, then three things may happen:

- a) Culture A eliminates culture B.

b) Culture A is absorbed by culture B.

c) Culture A assimilates culture B and produces culture C, that is, $A + B = C$.

What D'Ambrosio (personal communication, email, January 23, 2008) was speaking about is also related to work done by Walker and Quong (2000) in which it is necessary to confront the limits of uniformity. Who equate *borrowing* with *sameness*? Instead of finding models that encourage diversity, many of our social and educational institutions have grown to force *sameness*, often as an outgrowth of the trend towards globalization, which has, in turn:

(...) promoted the phenomenon of sameness, or what can be labeled “cultural borrowing”.

(...) Questions naturally arise about the relevance, applicability, validity, and appropriateness of theories, perspectives and policies which are transferred to, or borrowed, adopted by education systems whose cultures and situational conditions are quite dissimilar from those in which they were conceived (Walker & Quong, 2000, p. 73-74).

According to this context, one of the goals of any educational system should be fostering creative students. Creativity is a dynamic property of the human mind that can be enhanced and should be valued. Therefore, it is important to study creativity and determine its characteristics. Nature of mathematics through ethnomathematics provides a suitable platform for developing creativity.

On the other hand, ethnomathematics is closely aligned with the types of encounters in what D'Ambrosio (personal communication, email, January 23, 2008) calls *cultural integration*. It seems to us that *cultural borrowing*, a process of sameness and by which the *good* and the *accepted* has already been defined from the outside, cannot fit within the aforementioned dynamics.

In closing, we are left with a number of questions from our research that we look forward to looking into:

1. What happens when *non-represented* or *non-majority* cultures begin a process of *borrowing*? What does this borrowing infer, especially when technology gives them access to new mathematical ideas and vice versa? Is there a *sharing* between both parties, and just a *taking* of one by the other?
2. Can a reverse sense of *cultural borrowing* also happen? Especially in places with great cultural diversity such as Nepal, Brasil or California? Or is it a reverse colonization? Or can technology be mindfully used to what D'Ambrosio (2001) calls true *cultural integration*?
3. By using *ethnomodeling*, more traditional ideas are studied, categorized, and incorporated, how might this be reflected in and create new forms of mathematics?
4. How does technology influence borrowing? Does it accelerate the process, especially in rich environments such as long distance education, mobile learning, smart phones, and internet?

5. How might we use new technologies to create a dialogue by which all mathematical ideas contribute to the good of all humanity?

NOTES

[1] A huipil (from the Nahuatl *uipilli*, meaning *blouse*) is a form of Maya textile tunic or blouse worn by indigenous Maya women in southern México, Guatemala, Belize, El Salvador, western Honduras, and in the northern part of Central America.

[2] Mathematization is a process in which members from distinct cultural groups develop different mathematical tools that can help them to organize, analyze, comprehend, understand, and solve specific problems located in the context of their real-life situations.

[3] Retrieved from: <https://sites.google.com/site/trilhadeouorpreto/projeto-piloto-escola-municipal-alfredo-baeta>.

[4] The older standard linear measure that originated from measurements of area and volume was conceived in Egypt around 3000 BC. This measure was once called a cubit or bar, based on the length of the arm to the tip of the middle finger. Colonial Brazil, in the time of the Portuguese-Brazilian Empire, used a system that was often confusing and diverse in its measures because length was often measured in *barras*, and this pattern could vary from person to person, and region to region in Brazil and did not allow for a high precision in its measurements.

[5] Village.

[6] Rabbits.

[7] Cobblestones.

[8] <https://sites.google.com/site/meuetnomate/home/modelagem-matematica-mathematical-modeling>

[9] Courses in long-distance education as part of Universidade Aberta do Brasil offered through the Centro de Educação Aberta e a Distância at the Universidade Federal de Ouro Preto use Moodle as the platform.

[10] Some of the polos are located in small towns in the interior of Brazil and others in urban centers.

REFERENCES

D'Ambrosio, U. (1990). *Etnomatemática*. São Paulo, SP: Editora Ática.

D'Ambrosio, U. (1995). Multiculturalism and mathematics education. *International Journal on Mathematics, Science, and Technology Education*, 26(3), 337-346.

D'Ambrosio, U. (2001). *Etnomatemática: elo entre as tradições e a modernidade*. São Paulo, SP: Editora Autêntica.

Devlin, K. (2000). *The math gene: how mathematical thinking evolved and why numbers are like gossip*. New York, NY: Basic Books.

- Eglash, R., Bennett, A., O'Donnell, C., Jennings, S., & Cintorino, M. (2006). Culturally situated designed tools: ethnocomputing from field site to classroom. *American Anthropologist*, 108(2), 347-362.
- Florida, J. (2004). *The rise of the creative class and how it's transforming work, leisure, community and everyday life*. New York, NY: Basic Books.
- Gilmer, G. (1990). An ethnomath approach to curriculum development. *ISGEm Newsletter*, 5(2), 4-5.
- Langlois, J. (2013). *Protesters take to streets in Brazil*. USA Today. Retrieved from <http://www.usatoday.com/story/news/world/2013/10/15/brazil-protests/2987211>.
- Orey, D. C. (2000). The ethnomathematics of the Sioux tipi and cone. In Selin, H. (Ed.). *Mathematics across culture: the history of non-western mathematics* (pp. 239-252). Dordrecht, The Netherlands: Kluwer Academic Publishers.
- Orey, D. C. (2013). *What I want to be when I grow up*. TEDx Sacramento. Retrieved from https://www.youtube.com/watch?feature=player_embedded&v=anZNPNEgmUs#at=36
- Orey, D. & Rosa, M. (2006). Ethnomathematics: cultural assertions and challenges towards pedagogical action. *The Journal of Mathematics and Culture*, 1(1), 57-78.
- Rosa, M. (2005). *The ethnomathematics of Bakairi Body Painting*. NCTM Annual Meeting and Exposition: Embracing Mathematical Diversity. Anaheim, CA: NCTM.
- Rosa, M.; Orey, D. C. (2005). Las raíces histórica del programa etnomatemáticas. *RELIME*, 8(3), 363-377.
- Rosa, M.; Orey, D. C. (2010). Ethnomodeling: a pedagogical action for uncovering ethnomathematical practices. *Journal of Mathematical Modelling and Application*, 1(3), 58-67.
- Runco, M. A. (1993). *Creativity as an educational objective for disadvantaged students*. Storrs, CT: The National Research Center on the Gifted and Talented.
- Scientific American Brasil (2005). *Etnomatemática: edição especial*. São Paulo, SP: Ediouro Segmento - Duetto Editorial Ltda.
- Scott, R. P. (1992). Curriculum, resources, and materials for multicultural/multilingual classrooms. *ISGEm Newsletter*, 3-5.
- Toliver, K. (2008). *National math trail*. Retrieved from <http://www.nationalmathtrail.org/>.
- Urton, G. (1997). *The social life of numbers: a Quechua ontology of numbers and philosophy of arithmetic*. Austin, TX: University of Texas Press.
- Walker, A., & Quong, T. (2000). *Valuing diversity in schools: leaders confronting the limits of uniformity*. Mahwah, NJ: Laurence Erlbaum Associates.

CREATIVITY IN MATHEMATICS CLASS: HOW CAN IT EMERGE?

Sandra Pinheiro, Isabel Vale

School of Education, Polytechnic Institute of Viana do Castelo, Portugal

sandrapinheiro@ipvc.pt, isabelvale@ese.ipvc.pt

This paper focuses on a part of a wider study conducted about creativity in mathematics associated with problem solving and problem posing at elementary level. In this study, we developed a didactical experience for which we carefully selected some tasks, which would provide different productions, representing diverse and creative ways of thinking of each dyad, calling forth their creative potential and giving them freedom to communicate creatively. It can be concluded that the proposed tasks promote creative potential in students bringing out in them the habit for discovery and making a difference, compared to others.

INTRODUCTION

In this competitive and changing world students need to develop and improve their ability to think creatively and solve problems (Conway, 1999). According to the Principles and Standards for School Mathematics (NCTM, 2007), problem solving is essential in all of mathematics learning. The process of teaching and learning of mathematics using problem solving allows students to obtain different forms of thinking, practices of perseverance and curiosity, fostering confidence when facing unknown situations, being these abilities of extreme importance in and beyond the classroom, mainly in daily life of each student. According to Silver (1997) mathematics teaching that includes problem solving and problem posing will promote in students the use of more creative approaches.

PROBLEM POSING AND PROBLEM SOLVING

According to the NCTM (2007) good tasks are those that allow the introduction of key mathematical concepts, thus constituting a challenge to students, enabling them to use different approaches. In turn, Leikin (2009) states that multiple-solution tasks are those that consider different solutions to the same problem, those with different representations of mathematical concepts and those that involve different properties of mathematical objects in different fields.

Vale (2012) states that challenging problems usually require a different perspective, a complex and productive divergent thinking, mobilizing prior knowledge and requiring perseverance, constituting itself a challenge for the students. It is considered that divergent thinking involves looking at the problem, analyzing all the possibilities and searching for the best way to arrive at the solution to the problem (Vale & Pimentel, 2012).

Polya (2003) refers that problem solving in a mathematics class will be impoverished without coordinating with problem posing. The benefit of incorporating problems in the teaching and learning process of mathematics is widely recognized by the community of mathematics education (e.g. Kontorovich, Koichu, Leikin, & Berman, 2011) and in being able to deepen the mathematical concepts involved as well as understanding the processes resulting from the resolution (Boavida, Paiva, Cebola, Vale & Pimentel, 2008).

The literature on problem posing shows that this activity is relevant in various perspectives and also refers to the connections between problem posing and creativity. Creative activity is seen in the game made in the attempt to pose, to reformulate and eventually to solve a problem (Silver, 1997). Singer, Pelczer and Voica (2011) report that for having creative students in mathematics they should be able to put mathematical questions that extend and deepen the original problem, and solve problems in different ways, showing also the ability to pose problems, a condition of mathematical creativity. According to Singer, Ellerton, Cai and Leung (2011) to create a mathematical problem, we can induce students to achieve an authentic mathematical activity and to formulate their own problems begin to innovate, to create, to perform active learning (Shriki, 2013).

CREATIVITY IN MATHEMATICS

You can find creativity in all areas of human activity (e.g. arts, sciences, work, play) and everyone has any kind of creative abilities (National Advisory Committee on Creative and Cultural Education [NACCCE], 1999).

Sriraman (2004) states that Henri Poincaré is marked by quite a few authors as being the pioneer in the study of creativity in mathematics. Creativity is intrinsically linked to mathematics, but the education system does not value it in mathematics teaching and learning (Silver, 1997). “Everyone is born with enormous creative abilities. But these skills have to be developed” (Robinson 2010, p. 64). Currently, creativity is seen as a skill that can be enhanced in students with an appropriate selection of tasks (Pelczer & Rodriguez, 2011). Despite being complex to define creativity Gontijo (2007) considers it as being the ability to propose different solutions, appropriate to a situation or problem, so that they illustrate different characteristic of the problem and/or different ways to solve it, particularly, unusual ways.

Vale and Pimentel (2012) report that creativity is a forgotten subject by teachers during their math lessons may be because teachers have yet no knowledge on the subject and/or have not become aware of its relevance in mathematics education throughout the different levels of education. In fact, teachers and students need much more than merely the right and sound knowledge of mathematics to develop creativity in this area (Meissner, 2005). In this sense, Mann (2006) argues “the essence of mathematics is to think creatively, and not simply arrive at the correct answer” (p. 238). Leikin (2009), in turn, states that we must develop the mathematical creative potential of each student and this creative development should be a goal of school mathematics. Creativity can

be promoted through the use of non-routine problems and the teacher should be the supporter of a creative environment so that students are aware of their own abilities (Mina, 2008). Guerra (2007a) reinforced this idea when he says that creativity in mathematics education consists of a set of elements that contribute to see mathematics in the educational process as a surprising matter that develops flexible thinking, which encourages problem posing and situations that promote problem solving in a real context, that incites imagination, where the student dares to make mistakes and learns from his mistakes.

Cavalcanti (2006) reported that, according to Morin (1998), “all learning should be rich in meaning for the learner (meaningful learning) and should be flexible to allow multiple views of the same problem (cognitive flexibility)” (p. 97).

Silver (1997) and Guerra (2007a) argue that creativity is not just a characteristic of gifted and exceptional students, as in a classical view of creativity, but take a contemporary view of creativity in mathematics where creativity can be “promoted widely in the school population” (Silver, 1997, p. 75). To Sriraman (2004) “mathematical creativity is as a process that results in unusually insightful solutions to a given problem, despite the school level” (p. 51). These two lines of thought, classical and contemporary vision, although they differ in the type of people where you can find creativity, they converge when considering that creative activity results of directing the work of teachers to the creative methods of problem solving and posing (Leikin, 2009; Silver, 1997). Silver (1997) also notes that the connection of mathematics to creativity lies not only in the questioning, inquiring, but results from the connection between problem solving and problem posing and suggests that we can promote creativity in mathematics, but regarding the used way of teaching, that must be always extended to all students. Mann (2006) reminds us that in order for creativity to be recognized, appreciated and shared, it is necessary that the “development of mathematical communication skills” happens (p. 251).

Pelczer and Rodriguez (2011) suggest that research in creativity in mathematics education, is supported in the belief that creativity can be present in all students and can be promoted using tasks with adjusted structure. According, also, with these authors, the initial reports in creative mathematics emerged in the context of the work of mathematicians such as Poincaré and Hadamard. Mathematical creativity is essential in the development of talent in mathematics but also very difficult to identify and to evaluate (Mann, 2006).

Some authors (e.g. Balka, 1974; Conway, 1999; El-Demerdash & Kortenkamp, sd; Leikin, 2009; Mann, 2006) believe that the students' productions of problem solving must be analyzed taking into account three dimensions of creativity: fluency, flexibility and originality. Conway (1999) states that categories must be identified that include responses that the researcher believes are mathematically original or insightful. A procedure for assessing the three dimensions of creativity in problem solving consider for fluency the number of resolutions/different correct responses to a problem; for flexibility the number of resolutions/responses presented that illustrate different ways

of thinking that are different in nature, and for originality the number of unique or rare responses, compared with the resolutions of the class. Thus, problem solving is a privileged context for the study of creativity in mathematics classroom. This study followed up this perspective in the analysis of creativity in terms of problem solving.

According to Kontorovich, Koichu, Leikin and Berman (2011), many researchers consider that problem posing tasks can be a powerful tool for assessment of creative mathematics. In this study, problem posing followed the classification used by Stoyanova and Ellerton (1996), recurring to semi-structured situations, since the open situations presented to the dyads were photos, drawings, expressions, from which the dyads were asked to create problems.

Students have different backgrounds and skills, which leads to showing different potentials and different levels of creative thinking (Siswono, 2011). This author, after an investigation, indicates levels of creative thinking, based on the dimensions of creativity - fluency, flexibility, originality – for problem solving and problem posing. Leikin, Koichu and Berman (2009) regard for assessing problem posing also the same dimensions of problem solving. They consider for fluency the number of issues raised that fit the requirements of the task, for flexibility the number of different types of problems posed; and for originality the number of problems posed that are unique or rare. In this study, the procedure followed for the analysis of problem posing was an adaptation of the method in terms of originality, given that this dimension will be considered for different types of problems that are unique or rare placed, the latter being a maximum of two dyads. In this study we chose to adapt these levels to the creative performance of the dyads. Thus, we present four levels of creative performance, from level 0 to level 3, respectively from the least to the most creative performance, according to the dimensions of creativity applied to problem solving and problem posing. The respective characteristics of creative performance levels are shown in the following table:

Table 1. Characteristics of levels of creative performance adapted by Pinheiro (2013) from Siswono (2011).

<i>Level</i>	<i>Characteristics of creative performance levels</i>
Level 3	The dyad is able to solve problems with more than one solution and can present another way to solve it. The solution has originality. Can pose new problems. A problem has different solutions and different methods to solve it. Some problems constructed show originality, fluency and flexibility. The dyad tends to say that building a problem is more difficult than solving a problem, because in the resolution of problems there is a right way to reach the solution.
Level 2	The dyad is able to solve a problem with more than one solution but cannot introduce another way to solve it. The solution has originality. Moreover, they can pose an original problem. The problem has different solutions and different methods to solve it. They can use a different method for the construction of a problem.

Level 1	The dyad is able to solve a problem with more than one solution but cannot represent another way to solve it. No solution has originality. Are able to pose some problems. However the problem does not show up completely. The construction of problems complies with fluency, unoriginality or flexibility. The dyad tends to understand that different methods or strategies for solving a problem are another way of resolution.
---------	--

Level 0	The dyad cannot solve a problem with more than a solution and cannot represent another way to solve it. The solutions do not show originality, fluency and flexibility. They are not able to pose problems with originality and flexibility. The problems do not meet the originality, fluency flexibility. The errors are caused by lack of understanding of related concepts. The dyad considers that the construction of a problem is easier than solving a problem. The problems are not mathematically possible.
---------	---

During this study, the productions of the class and the dyads were analyzed in terms of creative thinking and will be categorized according to the levels previously reported.

CONTEXT AND METHODOLOGY

In this paper we describe the results of part of a broader qualitative study, that followed a case study design, in order to analyze and understand how it is possible to develop students' creativity through problem solving and problem posing (e.g. Stake, 2009; Yin, 2011). The researcher assumed a dual role in this study, teacher/researcher, observer and participant, with a privileged role in data collection, which, according to Yin (2011), reinforces the idea that the researcher is the first source in collecting data. The design of the didactical experience resulted through intensive study both in the field of problem solving and posing and in the field of creativity. The criteria for selecting the cases, which were aimed to obtain as much information about the problem under study, focused on students with different achievement levels and that were particularly good communicators, revealing abilities in terms of writing and speaking.

The didactical experience took place along math classes in a 5th grade class of twenty-one students, from nine to eleven years old, organized in dyads. This research, as mentioned above, aimed to study students' creativity through problem solving and posing, taking into account the types of tasks and analyzing the representations that students use in their resolutions. The implementation of the tasks of this study took place over seven sessions, each having duration of ninety minutes, where each dyad was proposed two tasks, in problem solving and problem posing, thus totalizing seven problem solving tasks and seven problem posing tasks. In each session, each dyad received a file folder, which contained the two new tasks. Each dyad managed the time available to carry out the tasks.

In this sense, it has become pertinent to explore different strategies for solving problems, providing students with tools that facilitated the achievement of tasks (Pinheiro & Vale, 2013). In this paper only the resolutions of two dyads will be analyzed in the context of problem posing.

In this learning proposal, in which tasks had a key role, we followed the model of Stein, Engle, Smith and Hughes (2008), having done prediction about tasks resolutions, together with the work performed by dyads during the application of tasks in a relaxed atmosphere; selected students for the presentation of their work to the class, organized the work, sequenced the productions of students from the most common to the most different and selected the students to make their presentations; promoted discussion with the class; and showed the connections between the resolutions and mathematical ideas.

The mathematical content approached in the didactical experience was the “non-negative rational numbers”. In all tasks, students were asked to analyze, solve and discuss the tasks proposed, giving emphasis to the statement, whether oral or written, including the representations made by the students. Data collection was carried out in a holistic manner, using field notes, two questionnaires, interviews and written comments from students, that included productions made in the classroom. To better understand if students had an idea of creativity in mathematics, an inquiry was conducted in the early operationalization of the study. At the end of the implementation of the tasks, students filled a questionnaire that expressed their opinion about the creativity of tasks and if they were promoters of creative productions, the degree of difficulty of the tasks, as well as the methodology that was carried out in the dyads. We also used interviews to both dyads that constituted the cases under study.

Throughout this study all data collected during the research (e.g. the productions of dyads, the audio and video records, field notes, written investigative reports based on observations, recordings, written documents) were carefully organized and analyzed according to the problem under study and the theoretical framework adopted and, in parallel, responding to the research questions.

RESULTS AND DISCUSSION

In the tasks¹ of problem solving and problem posing varied contexts were presented in order to allow different interpretations, ideas and problems.

Problem solving

Imagine you are a very famous painter. For your next frame, decided that it should be divided into different parts. Each part of the table should represent a fraction of $\frac{1}{3}, \frac{1}{4}, \frac{1}{6}, \frac{1}{8}, \frac{1}{12}, \frac{1}{24}$, of the frame. Imagine the dotted rectangle represents a screen background. Find out how to represent the different fractions and paints each one in different colors.

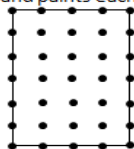

Can represent the fractions of the other modes? If yes, presents each of these modes in the following screens:

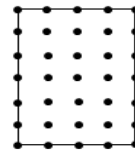
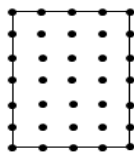
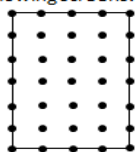

Figure 1. Example of problem solving task.

This task was one of the last because we considered the degree of complexity to be high. For this task, it was expected that students represented fractions in “block”, without leaving blanks in different parts. This dyad represented fractions as expected, Figure 2.

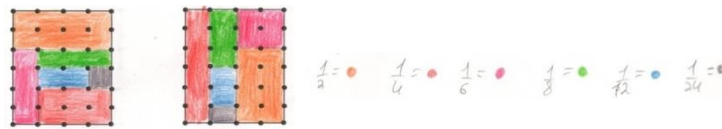

Figure 2. Most common resolution.

This dyad, on the other hand, had another solution, this time separating the pieces representative of each “block” of each fraction (Figure 3), which a small number of dyads also did.



Figure 3. Unusual resolution.

This dyad, unpredictably, presented two resolutions, one dividing the grid into two parts and another into four parts, Figure 4, and further stated that there were more solutions, drawing an ellipsis to reinforce this idea and claimed: “Yes. There are more ways to represent this situation.”

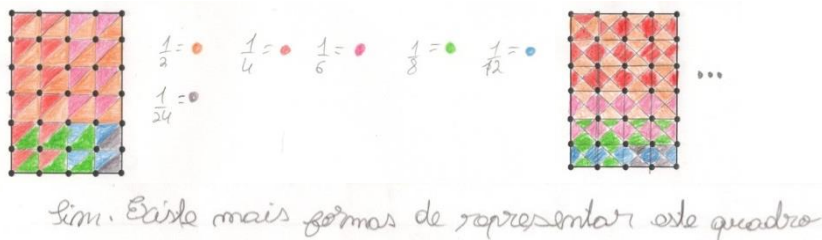

Figure 4. Quite rare resolutions.

Problem posing

Observes the square shown in figures.



Can you create a problem using the information of the two figures?

Solves the problem you created.

Figure 5. Example of problem posing task.

For this task, an original proposal made by a dyad stood out from the others (Figure 6), since no other dyad presented a formulation with a problem of this type. The dyad created the following problem: “Diogo invited 20 friends to his party and placed

successively in the 20 plates 2 napkins, as in figure 1 and figure 2. What was the disposition of the napkins on the twentieth plate?

Reply: Just as shown in Figure 2.”

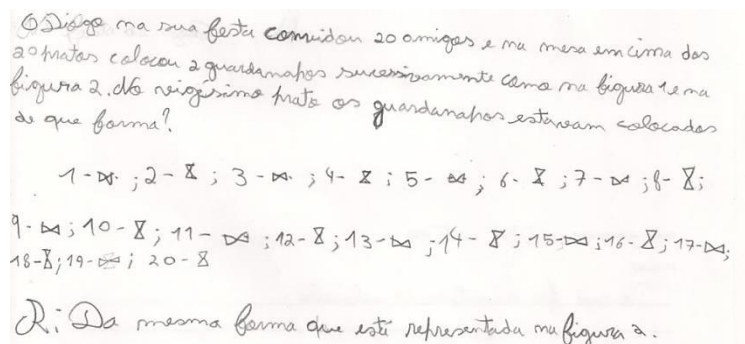

Figure 6. Formulation and resolution for the respective task.

This is a problem that, despite a disorganized statement, in terms of language, makes clear the objective of the problem. It's simple enough for the level of education, however, the dyad contextualizes the problem in order to work a repeating pattern, which is a topic rarely addressed by students.

Regarding the performance of the dyads, we present an overview of the results of the work undertaken, the two case studies and the remaining dyads of the class in table 2 and table 3. The tables summarize the results that are based on the three dimensions of creativity - fluency, flexibility, originality - either to solve problems or to formulate problems, evidenced by the performance of Matmasters, the Resolucionistas and the class, in each of the proposed tasks. In each task points were assigned to all dimensions: fluency, one point for each correct solution or resolution; flexibility, one point for each solution or resolution of a different nature, originality, one point for every single solution or resolution or unique (original). It is considered as unique if in maximum two dyads present the same solution and/or resolution. For the other dyads of the class, it was used the same process of assignment, writing down in the table the maximum score obtained for each dyad in each dimension and in each task. After a thorough analysis of all the work done, it was possible to complete table 2.

Table 2. Performance of the two case studies and the class in the context of problem solving.

Tasks	Dyads	Problem solving		
		Dimensions of Creativity		
		Fluency	Flexibility	Originality
	Matmasters	5	4	2
All	Resolucionistas	4	2	0
	Class	5	2	1

Looking closely to the data in table 2, we find that we have several variations depending on the dyad and on the task. It can be seen that the dyad showing, globally,

better performance in problem solving at the level of the dimensions of creativity is Matmasters.

For problem posing, we used the same table structure used in problem solving that draws upon the three dimensions of creativity - fluency, flexibility, originality - but applied to problem posing. This analysis was done on all the tasks. In this sense, the performance of Matmasters, Resolucionistas and of the class, in terms of fluency, flexibility and originality, was displayed. Counting the number of situations proposed in problem posing, a total of eight points were assigned in each of the dimensions: fluency, one point for each problem set according to the proposed situation and the possibility of withdrawal; flexibility, one point for each type of problem, created in accordance with the proposed system and possibility of resolution; originality, one point for every single problem created unique, according to the proposed situation and possibility of resolution, and considered unique when a maximum of two dyads present a problem of the same type. In terms of class we used the same process, registering in the table 3, the dyad with the higher score on that dimension among all the dyads in the class.

After a careful analysis of all the work, it was possible to complete table 3.

Table 3. Performance of the two case studies and the class in the context of problem posing (Pinheiro, 2013).

		Problem posing		
Tasks	Dyads	Dimensions of Creativity		
		Fluency	Flexibility	Originality
	Matmasters	8	3	2
All	Resolucionistas	8	2	3
	Class	7	3	1

Analyzing the data in table 3, we can see that the two dyad-cases, Matmasters and Resolucionistas, despite the low significance of the results, in general, had better performance in problem posing, in terms of the dimensions of creativity, in relation to the rest of the class.

Given the collected data, you can analyze the creative performance of the dyads, considering features of problem solving and problem posing revealed in the dyads productions based on the dimensions of creativity - fluency, flexibility, and originality. According to those dimensions it is possible to say that Matmasters fall within the level 3 of creative performance, since the dyad has been able to solve problems with more than one solution and presented another way to solve them. Still, in problem solving, solutions or resolutions presented showed originality in the group context. In terms of problem posing, for each situation proposed they could make at least one problem, thereby meeting the fluency. However, it also showed flexibility and originality in posing. A dyad, throughout the interviews, said that they had more difficulty in

formulating problems than in solving them, because to solve a problem “is only to understand and figure out how to get to the answer.” In contrast, Resolucionistas and the class fall within Level 2 of creative performance since they managed to solve a problem with more than one solution but occasionally were able to present another way to solve it. On the other hand, at least one of the resolutions or solutions showed originality. They were also able to formulate unique problems in terms of type, also showing some flexibility.

FINAL REMARKS

In this era of quick changes, students must feel that mathematics learning in schools emerges from the resolution of rich problematic situations, where students can create, share ideas and reason, promoting either mathematical thinking or creative thinking, facing mathematics positively and becoming active and critical citizens in society (Pinheiro, 2013). It becomes vital to break with traditionalism and, according to Robinson (2010), to allow students to explore truly their abilities, meeting their own expectations.

Students worked hard throughout the school year having the opportunity to draw on a diverse set of strategies of problem solving. On the other hand, they were encouraged to demand more, better and different solutions, promoting, in this way, divergent thinking (Pinheiro & Vale, 2012) and allowing, when faced with a task, to use their own potential tools. The development of the didactical experience in dyads has revealed to be very motivating for students and simultaneously efficient with respect to performance (Pinheiro & Vale, 2013b).

Problem posing cannot be unconnected from problem solving because they form a whole. As mentioned previously, students were not familiar with this type of tasks. However, several of the dyads productions, since it was something that “comes naturally to children” (NCTM, 2007, p. 58), emerged in the problem posing, revealing itself creative, since all the dimensions of creativity are patent there (Kontorovich, Koichu, Leikin, & Berman, 2011).

The work around creativity based on problem solving and problem posing provided varied experiences, rich and challenging, fostering different higher order cognitive skills, such as problem solving itself but also reasoning and communication, idea shared by Vale (2012) and raised by the students through a set of diverse and representative productions of different ways of thinking creatively.

All over the questionnaires several interesting ideas emerged from students responses. However it is worth to note two comments from two students who, in short, were able to express a lot: “creativity is not only art but the way (ability) to think” and “[math] is a creative discipline and it is with creativity that you can learn mathematics”.

NOTES

1. Adapted from the didactical materials of the Master classes of Didactics of Mathematics and Sciences.

REFERENCES

- Balka, D. (1974). Creativity ability in mathematics. *Aritmetic Teacher*, 21, 633-636.
- Boavida, A., Paiva, A., Cebola, G., Vale, I., & Pimentel, T. (2008). *A experiência Matemática no Ensino Básico - Programa de Formação Contínua em Matemática para Professores dos 1.º e 2.º Ciclos do Ensino Básico*. Lisboa: Ministério da Educação - Direcção-Geral de Inovação e de Desenvolvimento Curricular.
- Cavalcanti, J. (2006). A criatividade no processo de humanização. *Saber (e) educar*, 11, 89-98.
- Conway, K. (1999). Assessing Open-Ended Problems. *Mathematics Teaching in the Middle School*, 4, 510-514.
- El-Demerdash, M., & Kortenkamp, U. (s.d.). *The development of an Instrument to Measure Geometric Creativity*. Obtained january, 2012, in http://cinderella.de/material/gkt/files/gct_paper.pdf
- Gontijo, C. (2007). *Relações entre criatividade, criatividade em matemática e motivação em matemática em alunos do ensino médio*. Tese de doutoramento. Universidade de Brasília, Brasília.
- Guerra, E. (2007a). Creatividad en Educación Matemática. In S. d. Torre, & V. Violant, *Comprender y Evaluar La Creatividad* (Vol. 1, pp. 457-469). Archidona, Málaga: Aljibe.
- Guerra, E. (2007b). *Creatividad y desarrollo profesional docente em Matemáticas para la Educación Primaria*. Tese de Doutoramento. Universidade de Barcelona: Barcelona.
- Kontorovich, I., Koichu, B., Leikin, R., & Berman, A. (2011). Indicators of creativity in mathematical problem posing: How indicate are they? *Proceedings of the 6th International Conference Creativity in Mathematics* (pp. 120-125). Latvia: Latvia University.
- Leikin, R. (2009). Exploring mathematical creativity using multiple solution tasks. In R. Leikin, A. Berman, & B. Koichu, *Creativity in Mathematics and the Education of Gifted Students* (pp. 129-145). Rotterdam, the Netherlands: Sense Publishers.
- Leikin, R., Koichu, B., & Berman, A. (2009). Mathematical giftedness as a quality of problem-solving acts. In R. Leikin, A. Berman, & B. K. (Eds.), *Creativity in Mathematics and Education of Gifted Students* (pp. 115-128). Rotterdam: Sense Publishers.

- Mann, E. (2006). Creativity: The Essence of Mathematics. *Journal for the Education of the Gifted*, 30(2), 236-260.
- Meissner, H. (2005). Creativity and Mathematics Education. Paper presented at the *The third East Asia Regional Conference on Mathematics Education*. Retrieved from <http://www.math.ecnu.edu.cn/earcome3/sym1/sym104.pdf> .
- Mina, F. (2008). Promoting Creativity for all students in Mathematical Education. Paper presented at the *The 11th International Congress on Mathematical Education*, Monterrey, México from <http://dg.icme11.org/tsg/show/10> .
- NACCCE. (1999). *All Our Futures: Creativity, Culture and Education*. London: NACCCE.
- NCTM. (2007). *Princípios e normas para a matemática escolar* (1ª edição). (M.Melo, Trad.) Lisboa: Associação de Professores de Matemática (APM).
- Pelczer, I., & Rodríguez, F. G. (2011). Creativity assesment in school setting through problem posing tasks. *The Montana Mathematics Enthusiast*, 8, n.º 1 e 2, 383-398.
- Pinheiro, S. (2013). *A criatividade na resolução e formulação de problemas: Uma experiência didática numa turma de 5º ano de escolaridade*. Viana do Castelo: Escola Superior de Educação do Instituto Politécnico de Viana do Castelo.
- Pinheiro, S., & Vale, I. (2012). Criatividade: onde a encontrar na sala de aula? *Atas do XXIII Seminário de Investigação em Educação Matemática* (pp. 621-636). Lisboa: APM.
- Pinheiro, S., & Vale, I. (2013a). Criatividade e Matemática: Um caminho partilhado. *Ensinar e Aprender Matemática com Criatividade dos 3 aos 12 anos* (Atas) (pp. 30-39). Viana do Castelo: Escola Superior de Educação do Instituto Politécnico de Viana do Castelo.
- Pinheiro, S., & Vale, I. (2013b). Formulação de problemas e criatividade na aula de matemática. In Fernandes, J. A., Martinho, M. H., Tinoco, J., & Viseu, F. (Orgs.) (2013). *Atas do XXIV Seminário de Investigação em Educação Matemática*. APM & CIED da Universidade do Minho.
- Polya, G. (2003). *Como resolver problemas* (1.ª ed.). (L. Moreira, Trad.) Lisboa. (Trabalho original publicado em 1945): Gradiva.
- Robinson, K. (2010). *O Elemento*. Porto: Porto Editora.
- Silver, E. (1997). Fostering creativity through instruction rich in mathematical problem solving and problem posing. *ZDM*, 3, 75-80.
- Singer, F. M., Pelczer, I., & Voica, C. (2011). Problem posing and modification as a criterion of mathematical creativity. In T. Rowland, & E. Swoboda (Eds.), *Proceedings of the 7th Conference of the European Society for Research in Math Education* (CERME 7) (pp. 1133-1142). Poland: University of Rzeszów.

- Singer, F., Ellerton, N., Cai, J., & Leung, E. (2011). Problem posing in Mathematics Learning and Teaching: a Research Agenda. In Ubuz, B. (Ed.), *Developing mathematical thinking. Proceedings of the 35th PME*, vol 1, pp. 137-166(Research forum). Ankara, Turkey.
- Siswono, T. Y. (2011). Level of student's creative thinking in classroom Mathematics. *Educational Research and Review*, 6(7), 548-553.
- Sriraman, B. (2004). The characteristics of mathematical creativity. *The Mathematics Educator*, 14(1), 19–34.
- Shriki, A. (2013). A Model for Assessing the Development of Students' Creativity in the Context of Problem Posing. *Creative Education*, Vol.4, No.7, 430-439, Retrieved from <http://www.scirp.org/journal/ce>.
- Stake, R. (2009). *A Arte da Investigação com Estudos de Caso* (2.^a ed.). Lisboa. (Trabalho original publicado em 1995): Fundação Calouste Gulbenkian.
- Stein, M., Engle, R., Smith, M., & Hugues, E. (2008). Orchestrating Productive Mathematical Discussions: Five Practices for Helping Teachers Move Beyond Shown and Tell. *Mathematical Thinking and Learning*, 313-340.
- Stoyanova E., & Ellerton N. F. (1996). A framework for research into students' problem posing in school mathematics. In P. C. Clarkson (Ed.), *Technology in mathematics education* (pp. 518–525), Mathematics Education Research Group of Australasia: The University of Melbourne.
- Vale, I. (2012). As tarefas de padrões na aula de Matemática: um desafio para professores e alunos. *Interações*, 20, 181-207.
- Vale, I., & Pimentel, T. (2012). Um novo-velho desafio: da resolução de problemas à criatividade em Matemática. In A. P. Canavarro, L. Santos, A. M. Boavida, H. Oliveira, L. Menezes, & S. Carreira (Ed.), *Investigação em Educação Matemática - Práticas de Ensino da Matemática* (pp. 347-360). Lisboa: SPIEM.
- Yin, R. (2011). *Qualitative Research from Start to Finish*. New York: The Guilford Press.

STRATEGIES USED BY ELEMENTARY GRADE STUDENTS IN MATHEMATICS OLYMPIAD TESTS

Márcia Jussara Hepp Rehfeldt, Marli Teresinha Quartieri, Maria Madalena Dullius

Centro Universitário UNIVATES

mrehfeld@univates.br, mtquartieri@univates.br, madalena@univates.br

The Mathematics Olympiad of Univates (OMU) has the purpose of arousing the students' interest in solving mathematical problems and challenges. It also aims at stimulating the students to solve challenging and engaging problems. The tests consist of ten questions and are designed for the students from the 5th elementary grade to the last year of high school. In this work, the purpose is to share some strategies used by the students in solving OMU 2012 questions. It can be noted that calculation is still the manner most used by the students. However, it must be emphasized that some solutions may be considered rather creative, showing ability in solving situations by means of the students' own strategies, but with mathematical foundation.

INTRODUCTION

Problem-solving is cited in the National Curricular Parameters (PCNs) (Brasil, 1998), as the starting point for mathematics activities, giving the opportunity to develop the capacity of activating knowledge in various fields. The referred documents mention:

To understand the demands of the current work, it is undeniable that mathematics can contribute substantially to the measure that explores problem-solving and the construction of strategies as a way of teaching and learning mathematics in the classroom. Also, the development of the capacity for investigating, arguing, proving, justifying, and stimulating creativity, for the individual and collective work initiative, favor the development of these capacities (Brasil, 1998, p. 34).

In this sense, Dante (2000) affirms that the solution of problems can help the teacher in reaching one of the mathematics teaching objectives, which is achieving the student's productive thinking. Thus, it is interesting to show the pupils problem situations that involve, challenge, and motivate them in the desire for their solution.

With the purpose of stimulating students and teachers in solving challenges and contextualized problems, a team of UNIVATES University Center teachers and scholarship holders has held the Univates Mathematics Olympiad (OMU) since 1996. This event is an Institutional Extension project that depends upon the help of the National Research Coordination (CNPq). The condition for the participation of a school consists in having participated in the Brazilian Mathematics Olympiad (OBM).

The general purpose of the OMU aims at the fostering of taking pleasure in mathematics and the development of logical-mathematical reasoning and creativity through the solution of problems and challenges. Moreover, one has the intention of

stimulating the teachers to bring challenging questions to the classroom. Students from the 5th grade (former 4th grade) of the Elementary School to the 3rd grade of the High School participate in the OMU. This event includes various activities carried out during the year, among which are: publication of the event; acquisition, selection, and elaboration of the questions; test application and correction; pupils' reply analysis; records preparation; awards ceremony.

In this article, we shall present some strategies used by the pupils of the Elementary School (from the 5th through the 9th grade) in the 15th edition of the Mathematics Olympiad held in 2012.

THEORETICAL APPROACH

Surveys have shown that students show disinterest in mathematics and difficulties in solving problems. In this context, alternatives are discussed that motivate the students, making them feel stimulated and challenged. Moreover, mathematics is understood as an expression not disconnected from the other subjects and everyday life. One of the actions that worldwide have shown effectiveness is the Mathematics Olympiad, which according to Bragança (2013, p. 6) has the following objectives:

to provide an adequate environment to let the students, mainly those of the elementary and high school grades, discover their aptitudes and have the opportunity to apply their mathematical abilities; to have contact with the academic space that favors the teacher's development; to contribute encouraging and developing taking pleasure in mathematics; and to improve the teaching system, encouraging teachers to improve and find new resources for the enrichment of their classes.

In accordance with these objectives, one observes that the solution of problems can be considered an important contribution to the teaching and learning process of mathematics. Moreover, it allows the student the capacity to develop mathematical thought, not limiting him/herself to routine and uninteresting exercises that evaluate the learning process by reproduction and imitation. In this way:

[...] it is possible by means of solving problems to develop the student's initiative, exploring spirit, creativity, independence, and the ability to elaborate a logical reasoning and intelligent and efficient use of the available resources to make him/her propose good solutions to the questions that appear in his/her daily life, at school and outside it (Dante, 2000, p. 25).

The students, by solving problems, can discover new facts, motivating them to find other solution forms and arousing curiosity and the interest for mathematical knowledge. In this way, they develop the capacity for solving the situations that are presented to them. However, raising in the student the taking pleasure in solving problems is not an easy task, since there are many moments of difficulties, obstacles, and errors. For Cavalcanti (2001, p. 121):

To encourage the students to find different ways for the solution of problems allows a more elaborate reflection on the solution processes, be they through the traditional algorithms,

drawings, schemes, or even through verbal responses. Accepting and analyzing the different solution strategies as valid and important stages of the thought development allows the learning process by reflection and helps the student gain autonomy and confidence in his/her capacity to think mathematically.

Investigations have implied that one of the strategies used by the students in problem-solving is formal calculation (Dullius et al, 2011). However, it is up to the teacher to provide problems that allow the use of different strategies. The problem solving approach can enable the student to choose the path he/she wants to go through to get to the solution, as it mobilizes different knowledge bases to come up with an answer. Regarding the use of different strategies, Musser and Shaughnessy (1997, p. 188), highlight five ways that should be addressed at school in problem-solving: trial and error; standards (solution of individual cases finding patterns to be generalized); solving a simpler problem; working in reverse; and simulation (solution that involves conducting an experiment). Cavalcanti (2001), however, highlights drawing as an interesting strategy, as it allows the teacher “clues” of how his/her student was thinking while solving a problem.

Dullius et al (2011), by analyzing the test questions of high school students, found the following solution strategies: design, calculation, charts and graphs, trial and error, standards organization, reverse, lowering the unit. The most used strategy was calculation, followed by trial and error.

Dante (2000) suggests that teachers show the students different strategies for problem solving, such as: trial and error, search for patterns or generalizations, solving a simpler problem, reducing to the unit, going in the opposite direction. For the author, providing students with diverse strategies helps in finding the correct solution of the problems. Moreover, the knowledge of different strategies for solving problems can also help in the development of creativity. Creativity in mathematics, according to Gontijo (2006), comprises the ability to find ways and paths to solving problems, creating formulas and finding unique methods to solve non-traditional problems. Therefore:

We will consider creativity in mathematics as the ability to present numerous possibilities of appropriate solutions to a problem situation, so that they focus on different aspects of the problem and/or differentiated ways to solve it, especially unusual forms (originality), both in situations that require solution and preparing of problems and in situations that require sorting or organization of objects and/or mathematical elements according to their properties and attributes, either textually, numerically, graphically or in the form of a sequence of actions (Gontijo, 2006, p. 4).

Thus, the student, by presenting different strategies of appropriate solutions to the proposed situation, will be demonstrating beyond knowledge of content, creativity in mathematics. A competition like the Mathematics Olympiad can provide interesting situations in which creativity is developed. In the next section we will describe some important information about the OMU.

THE UNIVATES MATHEMATICS OLYMPIAD - OMU

The activities for the OMU realization begin in March each year, with the release of the event to the schools of the Taquari Valley region and neighboring regions, with the scholarship holders sending the required and relevant information. At the same time, in this month the scholarship holders perform searches for questions that excel by the use of logical reasoning, to be selected in an initial screening. This search is conducted through research into websites, books, and magazines, among others. Later begins the process of creating original questions by teachers of the Organizing Committee. These questions are prepared, by class, in which we will approach the content provided in the curriculum minimum of each class/year, and are mainly questions that develop logical reasoning.

The OMU occurs in two phases: the first phase is the Brazilian Mathematical Olympiad (OBM) held in July in the participating schools; and, the second is the Olympiad held at Univates, usually in the month of September. In 2012, 9,476 elementary and high school students participated in the OBM, and in the Mathematics Olympiad of Univates 2,170 students participated, from 61 schools and 20 municipalities. Students from the 5th grade of elementary school to the high school level participate in the OMU. The test is applied in a single session in the institution and lasts for three hours.

With respect to the test, some relevant points are highlighted. First, the possibility of making the test in couples, i.e., in pairs. Approximately 95% of the participants have chosen to carry out the tests in this way. It reinforces the idea of the importance of social exchanges, cooperation and collaboration, which are topics of wide discussion in teaching. Students can also use a calculator. Although there is no indication of the need for the use of the calculator, its use is allowed. This has brought comfort to the participants, who feel more secure and confident. There is also the possibility of choice of the questions, because the test consists of 10 questions, among which it is sufficient that the student choose to solve only eight. Exceptions are the 2nd year of high school, where the student needs to solve nine questions of 10, and the 3rd year, where the student must answer all of the proposed questions. This aspect is also considered positive, as it encourages the participant to make decisions. There are no differences in the test questions of the three years of high school, only the number of questions to be solved. With respect to the questions, about 30% are objective ones where the student has five alternatives from which he/she must choose the correct answer (multiple choice questions). The remaining questions are subjective ones (no alternative answers provided). However, the full development, with justification, in all questions is requested.

After the test completion, the correction stage occurs, which is made by at least two people, a professor and an extension scholarship holder. In addition to the answer, we observe the solving process of both the subjective and the objective questions, and an improvement in the solution processes presented by participants is highlighted in the solution analysis. In addition to the publication of the first three classifieds, the names of the twelve best placed, by class, are published for a greater incentive to participate

in later competitions. At the end of the questions correction, the best answers elaborated by the students are selected for the preparation and publication of the records, in the form of a CD-ROM, with the tests and the respective solutions presented by the students.

The awards ceremony is performed, in which the top three placed of each class are distinguished, and the duo with the best performance of each school receives an honorable mention. Also the fact that all students receive a certificate of participation and that the grades of all students are provided to the respective teachers is worth noting. As awards, in addition to medals, students can choose a gift from the following options: games, books, challenges, among others. To finalize the Mathematical Olympiad process, the survey and the analysis of the questions that show higher numbers of hits and errors, is carried out in order to assist in the preparation of future tests. In the next section, we will present some test questions of the 2012 OMU, as well as the strategies used by the students in their solution.

ANALYSIS OF SOME STRATEGIES USED

In the 2012 OMU, 2,170 students participated, distributed, by grade level, as shown in Table 1.

Table 1. Quantity of students per school year of the 2012 OMU (Fount: authors of the article, 2013).

Number of students per class	
Class	Number of students
4 th class/5 th year of the elementary school	274
5 th class/6 th year of the elementary school	288
6 th class/7 th year of the elementary school	344
7 th class/8 th year of the elementary school	352
8 th class/9 th year of the elementary school	306
High school	256
High school	184
High school	166

After the awards ceremony, a survey of the number of correct and mistaken questions in each test is carried out, as well as the number the annulled ones, i.e., those not solved by the students. In addition, in 2012, we performed an analysis of the strategies used by the students in each question. In this article, we will present only the analysis of the correct questions. In this way, assuming studies on solution strategies (Musser and Shaughnessy, 1997; Dante, 2000; Dullius et al, 2011), presented in the theoretical framework, we have decided to analyze the answers according to the following

strategies: trial and error, tables, drawings, patterns, reverse, reduction to the unit, calculation. We also have included in the survey those questions that present only the answer, without justification. After the quantitative analysis of the number of students who used each one of the above mentioned strategies, we have chosen to present in this article the question of each year of the elementary school that displayed the largest number of different strategies.

In the 4th class/5th year of elementary school, the following question obtained the largest number of different strategies at the time of the solution. The following strategies were used: trial and error, drawings, patterns, reverse, calculation and only the answer. In Figure 1, we show the design strategy that was used to obtain the answer.

As shown in the following figure, four people can sit at the square table. During the midmorning snack, the students moved seven square tables like that of the figure together to form a long rectangular table. How many people, at the utmost, can sit at the long table, considering that only one person can sit at each table side?



Podem sentar, na
mesa no maximo
16 alunos porque se
juntarmos todas
as mesas e contar-
mos um aluno de
cada lado da
16 mesa. 16 alunos na
mesa.

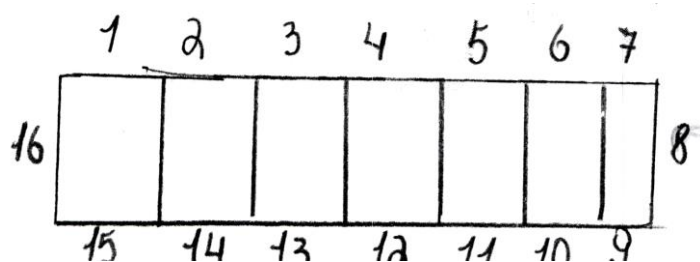

Figure 1. Solution of the question presented by a couple of students
(Fount: authors of the article, 2013).

We have observed that the students use the drawing for the solution. The tables were represented by rectangles that were drawn side by side to demonstrate their connection. Each side of the rectangle (which is the presentation of the table side) was numbered to demonstrate where one student can be sitting. Cavalcanti (2001, p. 127) mentions the use of the drawing “as a resource of interpretation of the problem and as a record

of the solution strategy”, which may provide the teacher with clues about how the student thought and acted to solve the problem.

In the 5th class/6th year, the question shown in Figure 2 obtained the largest number of different strategies.

In a bakery, a can of 200 g of chocolate milk powder CHOCOBN cost R\$ 3.00, a 400 g can costs R\$ 5.00 and one of 800 g costs R\$ 9.00. Lara needs 1.2 kg of CHOCOBN to make a huge cake. How many cans and of what type does Lara need to buy to make the most economical purchase of 1.2 Kg of CHOCOBN in this bakery?

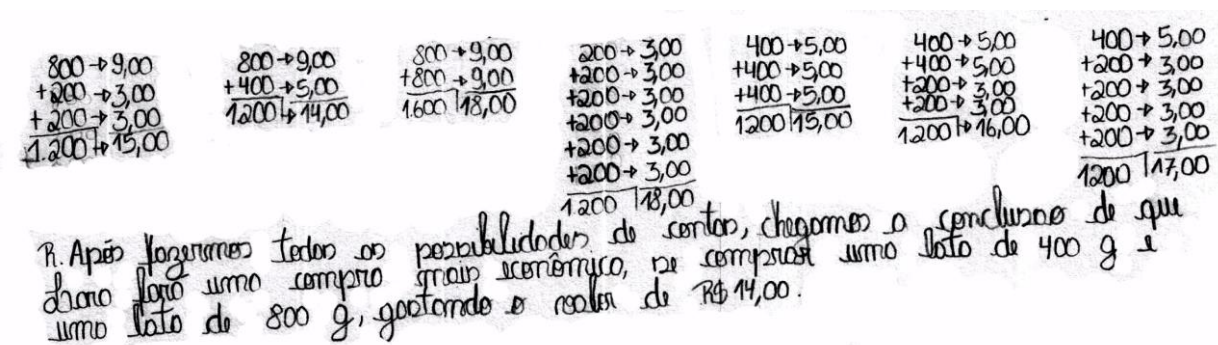

Figure 2. Solution of the question by a pair of students (Fount: authors of the article, 2013).

This question was solved correctly by 50% of the students who performed the test, using the following strategies: trial and error, drawings, patterns, calculation, only the answer. Calculation was used by 57% of those who answered correctly. In Figure 2 we show a solution in which the students have used trial-and-error, since various “weight” possibilities were tested and they verified the prices to find out the most economical one. According to Musser and Shaughnessy (1997), the trial-and-error strategy is one of the most-used by students in problem-solving. In this strategy, intuition, imagination, creativity, tips, and experimentation are present at the time of the solution. The student starts the solution with any estimated value and tests the validity, or not, of this value.

In the 6th class/7th year, the following question was the one that students most correctly answered and used the following solution strategies: trial-and-error, tables, patterns, reverse, calculation, only the answer.

Sofia took some sweets to her grandma: seven mulberry sweets, six chocolate, and three coconut ones. Along the way, the greedy Sofia ate two sweets. Which of the situations below is possible?

- Grandma did not receive chocolate sweets.
- Grandma received fewer coconut sweets than chocolate ones.
- Grandma received the same number of sweets of each of the three varieties.
- There are two varieties of sweets of which grandma received the same quantity.
- The number of mulberry sweets grandma received is larger than that of the sum of the other two.

$a) 3-2=1 \neq 0$ $b) 6-2=4 > 3$ $c) 7-1=6$ $6-1=5$ $5 \neq 6 \neq 3$
 $d) 7+1=6$ $3-1=2$ $6-0=6$ $6=6$ $e) 3+6=9 > 7$ $9-2=7$
 Das situações a cima, a única possível e a afirmativa d.

Figure 3. Solution presented by a pair of students of the 6th class/7th year (Fount: authors of the article, 2013).

In Figure 3, we observe that students have analyzed all the alternatives, to see which one might be the correct answer. After several attempts, the students realized that option 'd' would be the only one possible.

Here follows the question of the 7th class/8th year that showed the highest number of different strategies.

A craftsman starts working at 8 o'clock and produces six bracelets every 20 minutes. His helper begins to work an hour later and produces eight bracelets of the same type every half hour. The craftsman stops working at 12 o'clock, and tells his helper to continue working until he reaches his own production. At what time will the helper stop?

CHEFE:			AUXILIAR	
8:20 = 6	10:00 = 36	12:00 = 72	9:30 = 8	12:30 = 56
8:40 = 12	10:20 = 42		10:00 = 16	13:00 = 64
9:00 = 18	10:40 = 48		10:30 = 24	13:30 = 72
9:20 = 24	11:00 = 54		11:00 = 32	
9:40 = 30	11:20 = 60		11:30 = 40	
	11:40 = 66		12:00 = 48	

Figure 4. Solution of a couple of 7th class/8th year students (Fount: authors of the article, 2013).

The students have solved the problem creating a table that enables an organization proper with relation to the question. Thus, they put the time period with the corresponding number of bracelets produced by the craftsman and by the helper. Finally, they determined, by this prepared organization, the time at which the helper could stop producing bracelets.

In relation to the test of the 8th class/9th year, the question that follows had the largest number of different strategies, the most used being calculation.

In a test, the first six questions were of true/false type, in which the candidate should choose between right or wrong for his/her reply. In the other four questions, the candidate should choose the correct one among three alternatives. How many sequences of answers are possible in solving the test?

- a) $(6 \times 2)^2$ b) $(6.2) + (4 \times 3)$ c) $6^2 \cdot 4^3$ d) $10^{(2+3)}$ e) $2^6 \cdot 3^4$

Temos que as seis primeiras questões tem 2 alternativas.
No caso $2 \cdot 2 \cdot 2 \cdot 2 \cdot 2 \cdot 2 = 2^6$, que é para saber o
maior número possível de sequências. As questões
7, 8, 9 e 10 tem 3 alternativas, logo $3 \cdot 3 \cdot 3 \cdot 3 = 3^4$
juntando os resultados teremos $2^6 \cdot 3^4$.

Figure 5. Solution of a couple of 8th class/9th year students
(Fount: authors of the article, 2013).

Cavalcanti (2001, p. 143) points out “the use of the conventional algorithm as one more solution opportunity”. In this question, most students used calculation to solve it, as exemplified in Figure 5. However, it is necessary to note that the students have justified the reason for using calculation for this solution.

According to the PCNs (Brasil, 1998) the solution of a problem implies understanding of what has been proposed and presenting the answers by applying appropriate procedures that enable the use of multiple paths to reach the same result. This can be observed in the performed analysis, when we realize that the students have used various solution strategies. However, the strategy most used by students in the analyzed questions was calculation. This result is in accord with the one found in Dullius et al. (2011, p. 10), studying the test held by high school students in the 11th OMU. This was noted in strategies created by the students themselves, in the use of tables presenting organizations that showed proper organizations in different designs and in trial-and-error examples demonstrated in the solutions.

We emphasize that students, even if they often used the knowledge and methods acquired in the classroom, such as calculations and formulas, also showed signs of creativity. Thus, we can infer that students, when challenged, end up creating their own strategies for problem solving, as reported in the response shown in Figure 6, the proof of the 8th class/9th year previously mentioned. The preparation of a table in solving problems like this is not something typical for students, nor for teachers, which illustrates a creative and organized way of logical thinking.

Grid	Solution
1	2
2	0
3	0
4	0
5	2
6	0
7	3
8	3
9	3
10	3

Figure 6. Solution of a couple of 8th class/9th year students
 (Fount: authors of the article, 2013).

In learning mathematics, the problems ultimately become fundamental, since they can allow the student to face questioning and thinking for him/herself, enabling the exercise of logical reasoning and not just the use of standardized rules, as Amado and Carreira (2012, p. 15) point out well.

Solving mathematical problems requires more than knowledge of procedures and techniques, it requires the ability to motivate the student and put him/her into action, to think of strategies that, at the beginning, are not pre-established, and to make full use of various ways of communicating the reasoning and solution process. In the end, it implies the mobilization and development of a variety of skills to reach an end. The individual does not have, in advance, any algorithm or procedure already constructed that assures the correct solution.

Thus, we believe, according to Gontijo (2006), that a problem, no matter how simple it may be, can arouse interest in mathematical activity if it provides the student a liking for the discovery of a solution, stimulating curiosity, creativity and the improvement of reasoning, as well as extending mathematical knowledge.

SOME CONSIDERATIONS

Since the first Univates Mathematics Olympiad editions, we have observed an increase in the number of participants, as well as the involvement of the teacher and his/her students, both in the period of the Olympiad and in its preparation. Most participants opt to take the exam in pairs, because it provides greater security. During the test, we have observed the discussions of the pairs, engaging each other for a good performance in competition. In addition, the use of the calculator, for the solution of the questions, has been considered a positive aspect, both by teachers and by the students.

In relation to the solutions, we have observed that students opt to solve the questions using formulas and calculations presented in the classroom, when they could have solved them by trial-and-error, drawings, diagram, or by another strategy. According

to Dante (2000), the teacher should offer the students the possibility to use several strategies, showing them that there is no single optimal strategy for a solution. For the author, it would be interesting to solve different problems with the same strategy as well as apply different strategies to solve the same problem. In this sense, the teaching of mathematics enables the exercise of logical reasoning, as well as the development of creativity, as Romanatto (2012, p. 11) points out.

Mathematics needs to be presented to the student as a knowledge which favors the development and improvement of his/her reasoning, expressive capacity, sensitivity, and imagination. Therefore, the process of teaching and learning mathematics needs to transform itself, from a mere technical training, to an instrument to model and interpret reality in its most diverse contexts. That means training for creativity, criticality, and citizenship, and not only for memorization, alienation and exclusion.

We point out that the various OMU editions provide rich material that allows analysis of the most critical content for the students in terms of learning mathematics. We have also realized that in the course of the OMU editions the students “feel” the natural pleasure for competitions, since the number of participants is significant. We hope with this event to educate students that good results are achieved with effort, dedication and creativity.

REFERENCES

- Amado, N. & Carreira, S. (2012). Um olhar sobre uma competição matemática na Web – a resolução de problemas para além da sala de aula. In *Revista Educação e Matemática*, p. 13-18, set-out.
- Bragança, B. (2013). *Olimpíada de Matemática para a Matemática avançar*. Dissertação (Mestrado). Universidade Federal de Viçosa. Viçosa, MG.
- Brasil, Secretária de Educação Fundamental. (1998). *Parâmetros Curriculares Nacionais: Matemática*. Brasília: MEC/SEF.
- Cavalcanti, C. (2001). Diferentes formas de resolver problemas. In: Smole, K. S. & Diniz, M. I. (Orgs.). *Ler, escrever e resolver problemas: Habilidades básicas para aprender matemática*. , pp. 121 – 149. Porto Alegre: Artmed.
- Dante, L. (2000). *Didática da resolução de problemas de matemática: 1ª a 5ª class*. 12. São Paulo: Ática.
- Dullius, M. M. [et al]. (2011). Estrategias utilizadas en la resolución de problemas matemáticos. *Revista chilena de educación científica*, v. 10, n. 1, p. 23-32.
- Gontigo, C.H. (2006). Resolução e Formulação de Problemas: caminhos para o desenvolvimento da criatividade em Matemática. In *Anais do SIPEMAT*. Recife, Programa de Pós-Graduação em Educação-Centro de Educação – Universidade Federal de Pernambuco.
- Krulik, S. & Reys, R. E. (1997). *A resolução de problemas na matemática escolar*. São Paulo: Atual.

Musser, G. L. & Shaughnessy, J. M. (1997). Estratégias de resolução de problemas na matemática escolar. In S. Krulik, & R. E. Reys, (Eds). *A resolução de problemas na matemática escolar*. São Paulo: Atual.

Romanatto, M. C. (2012). Resolução de problemas nas aulas de Matemática. *Revista Eletrônica de Educação*, 6(1), pp. 299-311. Retrieved from: <http://www.reveduc.ufscar.br>.

WRITING PROBLEM STORIES: DEVELOPING CREATIVITY THROUGH THE INTEGRATION OF MATHEMATICS AND LANGUAGE

Fátima Sardinha, Pedro Palhares, Fernando Azevedo

CIEC, Institute of Education, University of Minho

fatimasardinha@gmail.com

Writing problem stories is a teaching methodology whose main objectives are: allowing children to pose problems and to write stories and therefore to integrate the two main subject areas of the curriculum, language and mathematics. With it we intended to promote the development of creative writing, textual understanding, problem solving, problem posing and reflective and creative thinking. The non-routine problems were used in order to maximize varied and creative strategies of solving problems, allowing students to apply their knowledge in posing problems activities.

PROBLEM STORIES

Our study intended, in a first stage, to promote, and in a second stage, to assess the development of literacy and numeracy skills using a problems stories teaching strategy, with students primary school. Our study first was implemented in small scale by Sardinha (2005). The relevance of this study lies in the education for numeracy and literacy, as well as in a change of attitude towards mathematic and language through problem stories. Their creation implies reading, writing and posing and solving problem skills in specific context.

We pretended to analyze and reflect on the consequences of implementing this method as a way of educating for numeracy and literacy, longitudinally, articulating transversely mathematics and language. We intended to perceive the skills that this teaching method may develop in students and how this affects their long term achievement in both areas.

The construction of stories with problems (problem stories) was an activity promoted by Bush and Fiala (1993) as a new way to have students posing problems. That was done both with 5th grade students and teacher trainees. They thought that the construction of problem stories would develop creative writing and integrate mathematics with other areas, and could be done with students of every school year.

Palhares (1997) has implemented and analysed problem stories made by teacher trainees. He stipulated groups of 2-3 and that stories should have exactly four problems coherent with the story and should be intended to 8th grade students. He mentions three structure factors in the construction: the general idea for the story, the development of the story and the problems, any of which may assume the most relevant part.

Apparently there are four different and main processes of construction. One is to start with only one problem, from which the general idea of a story unfolds and during its development opportunities to include other problems may arise. A second is to start with a set of problems, from which a general idea emerges and a later adaptation of the problems occurs. Third, we start with the idea for a story and opportunities for the introduction of problems arise which may originate changes in the development of the story. Finally, there is the possibility of constructing a story and when it is finished, formulate problems coherent with it and place them strategically. He believes that the first two favour problem posing and the last two are more favourable to the construction of stories.

Sardinha (2005) has implemented the creation of stories in a 3rd year of schooling class. She created tasks not only for problem posing and solving, but also for the understanding of texts and to develop writing. She concluded that problem stories permitted the understanding of the importance of the strategic management of information in a text, considering the perlocutive effects to be attained; developed the domain of the basic moments in stories structuring; and developed several other competencies connected both with the domain of Portuguese language and with problem posing and solving. She mentions that problem stories have promoted and facilitated the use of problem solving strategies by facilitating the creation of mental images of the problem settings, together with better metacognitive actions.

Sardinha (2011) has implemented again the tasks to a new group of students of the 2nd year of schooling and continued working with them through their 3rd year of schooling. The set of tasks was remade from 2005, with a new non-routine problem and a new story rewriting activity.

In 2012, we have set up a teacher in-service training focusing on this methodology in which fourteen teachers have participated. We intended teachers to create their own tasks, starting from the sequence of tasks by Sardinha (2011), and then applied it to their students. For the first time this methodology was applied to three 1st year of schooling classes.

Integration

Pat Hagerty, cited by Evans, Leija and Falkner (2001), recommends disciplinary integration as a means to help teachers deal with the lack of time to work all curricular content in the classroom they feel. Considering that literacy is one of the first to be evaluated, he proposes the integration of all possible areas to work around literacy.

Azevedo (2009) refers that educating to literacy involves creating interaction opportunities with literacy materials that are both significant and relevant.

In our specific case, when trying to interact between literacy and numeracy through the creation of problem stories, we believe that problem solving and posing are strongly connected with the linguistic domain and therefore it makes all sense to integrate these two basic areas for a global development of the students.

Even if some may say that integration is just fashionable, we think that in the pedagogic domain it is still ill represented. And our methodology intends to achieve an effective integration between Language and Mathematics with the students being an active part in the construction of tasks and of their own knowledge.

Creativity

Van Harpen and Sriraman (2013) refer that creativity is seen has a major component of education and a buzzword of the twenty-first century. Research on creativity specifically in mathematics is sparse, according to Leikin et al. (2010). Mann (2006) points to the lack of a consistent definition of creativity.

To Guilford (1967) the creative process is based on the combination of convergent thinking, that involves aiming for a single, correct solution to a problem, and divergent thinking, that involves generation of multiple answers to a problem or phenomenon. An operative definition of creativity based on four related components is suggested by Torrance (1974): fluency, flexibility, novelty, and elaboration. *Fluency* is the continuity of ideas, flow of associations, and use of basic and universal knowledge. *Flexibility* is associated with changing ideas, approaching a problem in various ways, and producing a variety of solutions. *Originality* is characterized by a unique way of thinking and unique products of mental or artistic activity. *Elaboration* refers to the ability to describe, illuminate, and generalize ideas. As creativity is usually viewed as a process that leads to generation of original ideas, the originality component is commonly acknowledged as the main component of creativity.

Cropley (2006) shows another view of the combination of convergent and divergent thinking. For this author, creative thinking involves two main components: “generation of novelty (via divergent thinking) and evaluation of the novelty (via convergent thinking)” (p. 391). At the same time, convergent thinking knowledge is of particular importance as a source of ideas, pathways to solutions, and criteria of effectiveness and novelty.

Problems, problem posing and creativity

Kantowsky (1977) points to the difficulty in defining problem, since what is a problem for some may be an exercise for others or even a known fact for yet others. In the same direction goes Schoenfeld (1985) who stresses the relativity of the notion.

Mayer (1992) considers that we face a problem when we have an objective but we do not have immediate access to the solution, because we are facing an obstacle. Mayer (2002) adds to it that mathematical problem solving is the problem solving when a mathematical content is present, explicitly or implicitly. This definition by Mayer is compatible with Polya (1965), for whom solving a problem is to find a path out of a difficulty, a way to contour an obstacle, to pursue an objective that is not immediately achievable.

Vale e Pimentel (2004) point the difficulty in defining what is a problem. They also refer that many terms have lately appeared, to some authors they are synonyms of problem and for others aren't. The word "problem" can mean a task or a project, an activity or an investigation. In our case, the word "problem" assumes an open character in which students can use a wide range of solving processes and where they investigate to reach the solution. The authors refer to the international recommendations that value the complex mathematical processes and students creativity, stressing that non-routine activity converge in this way. According to this, they consider crucial the selection of exploratory and investigative problems that allow challenges to all students, so that they can formulate hypotheses, verify conjectures and promote debate in the resolution.

We finally used Palhares (1997) definition of problem: a problem is constituted by information on an initial situation and on the final situation that is required, or on the transformation that is required; there is an obstacle for a certain class of individuals that implies the use of some kind of reasoning to get a solution by their own means (or one solution, or the certainty that there is no solution); the class of individuals for whom there is an obstacle have to apply one or more strategies; there can be no indication on which strategy to use.

We agree with the definition of problem posing by Gonldenberg and Walter (2003) in which they refer that it is simultaneously a tool to teach mathematics through problem solving and a part of the learning. They say that for students the process of posing their own problems helps develop the ability to solve problems and to understand the implicit mathematical ideas. For Mann (2006) solutions to real problems also entail problem finding, as well as problem solving. Kilpatrick (1987) described problem posing as a neglected but essential means of mathematical instruction. The author emphasize that students need the opportunity to design and answer their own problems.

Krulik and Rudnick (1993) corroborate the essence of problem stories, because students gain experience in creating their own problems and these become increasingly sophisticated. They defend that problem solving and reasoning should go beyond what appears in textbooks. To develop students into thinking subjects, we should confront them with situations that require resourcefulness, creativity and imagination.

Jay and Perkins (1997) state that "*the act of finding and formulating a problem is a key aspect of creative thinking and creative performance in many fields, an act that is distinct from and perhaps more important than problem solving*" (p. 257).

Ervynck (1991) identified three different levels of creativity: first - contains an algorithmic solution to a problem; second - involves modeling a situation and may include solving a word problem with a graph or a linear diagram; third - employs sophisticated methods usually based on assumptions embedded in the problem, and makes use of the problem's internal structure and insight. Since categorisation of types of solutions according to the levels of creativity suggested by the author is based on the connection between the solutions and solver's previous mathematical experiences,

this categorization fits the definition of relative creativity, in general, and of originality, in particular.

Leung and Silver (1997) claim that both problem solving and problem posing are important aspects of mathematical creativity. However, Van Harpen and Sriraman (2013) consider that problem posing is also the least understood and most overlooked part of mathematical creativity, as there aren't many studies that have investigated the relationship between mathematical creativity, in the form of problem posing, and mathematical achievement, ability and/or knowledge.

METHODOLOGY APPLIED

After Sardinha (2005), we have created a specific methodology, divided in two moments, and these moments divided in three phases, and in each phase pursuing different goals for both areas, always respecting the interdisciplinary approach.

In the first year, we chose a group of five 7-years old students on their 2nd year of school (group A). In the second year, we analyzed four elements of the group A, in their 3rd year of school, and also another group (group B), a four students group of 8-years old average in their 3rd year of school, experiencing this method for the first time. Introducing a new group, we intended to compare the results of their work, in the field of posing and solving problems and in the creativity of the problem stories and their proficiency in the use of the language. Group A had contact with problems stories in the first year of the study and group B never experienced them before.

The elements of the groups were chosen according to the will of the students in participate in the study and according to the will of their parents since we did the activities in extracurricular time.

Data was collected in a natural context and we did a direct and participative observation. We used video recordings, analyzed the contents of their stories and the way they solved and posed problems and we also did interviews.

In the initial phase, in three sessions, we worked with non-routine problems, the expansion of problems statements and also the macro-textual analysis of stories.

The first activity proposed was the problem story "Raspel the misfortunate" constructed around the well known problem of the wolf, goat and cabbage. It was a story about a gnome, with a lot of bad luck, who needed to find the wish-tree to end his misfortune. In his adventure he was always with a goat, a cabbage and a wolf. At some point of the voyage he came across a river and a problem arose, how could he cross the river to get to the tree if he only had a boat with two places? Apart from this, if they were left alone, the goat would eat the cabbage and the wolf would eat the goat. How many trips must he do to cross to the other side? In the second and third activities we posed the problems: "Riddle of St. Mathias" (When I was going to St. Mathias I met a boy with seven aunts. Each aunt had seven bags and each bag had seven cats and each cat had seven kittens. Kittens, cats, bags and aunts how many of them were going to St. Mathias?); "The Squirrel" (A box has nine cabbage eyes. The squirrel leaves with

three eyes per day, however he takes nine days to transport all the cabbage eyes. How do you explain this fact?); “Sebastian the Crab” (Sebastian the crab decided to go to the beach. He was in the sea, twenty meters off the beach. Each day, he walks four meters towards the beach. But at night, while he rests, the tide throws him back two meters. How many days will it take him to get to the beach?). We asked them to create a story including the problems we used.

In the development phase, in two sessions, we created a version of the Snow White Story, in which she is a participant narrator. In this phase, from the traditional story, pupils had to pose coherent problems with it.

In the final phase, in two sessions, students had to create a story and formulate coherent problems with the story. This methodology was used with group A.

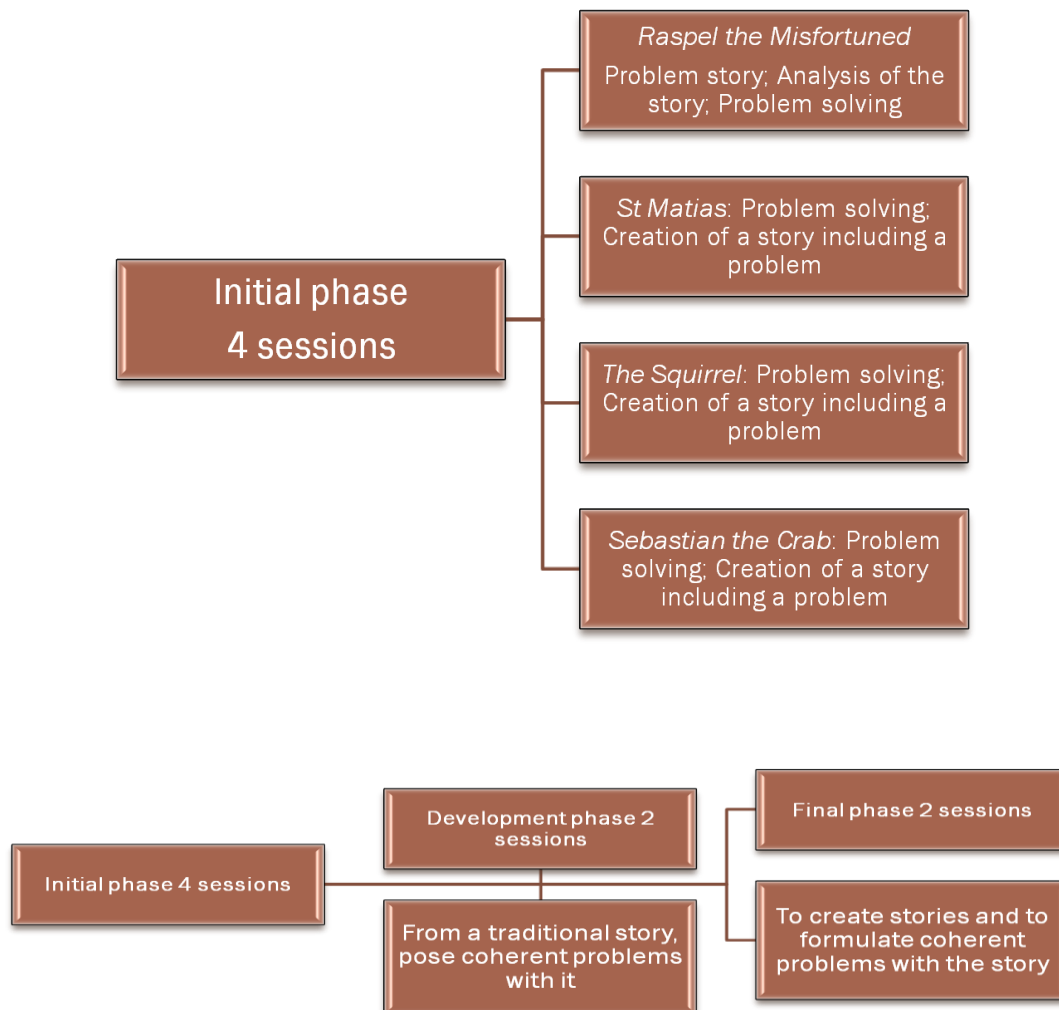

Figure 1. Scheme of the method used with the 2nd year of schooling students.

In the second moment, second year of the study, we introduced a few changes. Group B started its participation in this study without the contact with problem stories that group A experienced. We posed new problems: “Indians paths” (The chiefs of the

Indian tribes of Sioux, Oglala, Comanche, Apache, Mescaleros and Navajos gathered for a big Pow-Wow (it's how the Indians call their meetings). In the top of the hill, they put their tents making a circle. Each tent had a path to the others. How many paths were there?), "Jealous boyfriends" (Two couples of jealous boyfriends, John and Joana, Antony and Antonia, wanted to cross a river where there was a little boat. This boat took only two persons. The problem was that the boys were so jealous that they would not leave their girlfriends with the other boy, even if the others girlfriend was there. How could they do to cross the river?), and "The thinker" (André thought of a number. Then he multiplied it by two. After that he subtracted five. The result was thirteen. Which number was it?). Later we asked again for the creation of a story including problems used. In the development phase, in two sessions, students had to create their own story and formulate coherent problems with the story, like group A had already made in the first moment. In the final phase, two sessions, we asked both groups to rewrite the story, students should reflect about their work for improvement, correcting and enrichment of the problem story. So, group A just had to apply their knowledge and strategies acquired in the first year and group B had to perform the same work without any previous contact with problem stories. We intended to identify possible qualitative differences in their work in the problem posing and in the creation of problem stories.

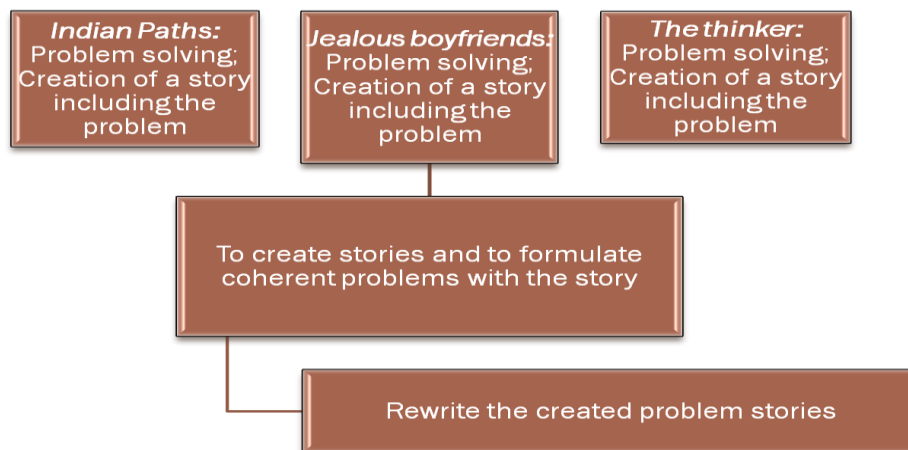

Figure 2. Scheme of the method in the second moment

ANALYSIS OF THE PROBLEM POSING

The first problem the students had to formulate was about the distance White Snow had to walk from the castle to the dwarfs' house. Students revealed difficulties expressing their ideas, so the teacher had to help them.

Teacher: So we can write a problem on measurement, using what?

Bernard: Kilometres.

Teacher: Didn't you solve a similar problem?

Bernard: Yes, we did, the turtle, how many hours did she get to arrive.

During the formulation of the problem, students chose re-contextualization of a previous problem, yet revealed difficulties in justifying why Snow White backed off in the course from her father to the dwarfs' house.

Bernard: She was a sleepwalker, she missed her daddy and slipped just a little and then perhaps it's better to think it better...

Students: Left my father's house...

Anthony: That was twenty kilometres from this one. Every day I walked 4 Km. and ay night?

Bernard: How was it? She missed her father, she was sleepwalker...

Four elements of the group drew a line with 20cm representing the 20 Km and signalled in one side what she was walking during daytime and in the other what slipped back at night and then counting. The fifth element observed that she only walked three km per day

The fifth element, observing that White Snow only made 3 km per day, added successively until reached 21, and then counted how many additions were.

Students have shown difficulties in identifying opportunities to create problems as well as in reasoning mathematically, and the formulation allowed for the students to reflect on aspects of real life, like time to travel in bus and so on.

Bernard: Kilometres!

Anthony: Kilometres!

Teacher: And how many km did they travel per hour?

Bernard: Per hour?

Teacher: You have to say it otherwise how can we know?

Bernard: Five!

Ann: Five!

Bernard: It is to get there quickly.

Teacher: Usually how many km per hour?

Several: Hundred!?

Bernard: Yes it is one hundred, yes.

Then students formulated a problem on this basis.

Teacher: How much did they travel per hour?

Daniel : One hundred km.

Teacher: Every hour they travelled 100km. and what do we want to know?

Anthony: How many km did they...

Teacher: “on a certain day the four friends went on a school study trip to the Lisbon Zoo, they left school at eight fifteen and arrived there at eleven, they travelled 100km every hour how many km did they have to travel to...

Anthony: ...to get there.

Teacher: ...to get there.

When solving the problem formulated, students showed many difficulties measuring the duration of the trip, and in general working with time measurements. The worst bit was working with the quarter of an hour and the distance travelled in that period of time.

To illustrate the work done, we transcribed the problem story analysed and the resolution of the problems posed by the pupils that shows how they have to be creative in the process of solving their own problems.

Problem story: An adventure in the Zoo

Once upon a time there were four friend called Daniel, Anthony, Bernard and Ann. They all studied in the same school and Anthony and Bernard were cousins. They got themselves in lots of troubles mainly because they were very curious.

One day, the four friends went in a school trip to the Lisbon Zoo. They left school at 8h15m and arrive there at eleven. Each hour they travelled one hundred kilometres. How many kilometres they made to arrive to their final destination? (1)

Upon arrival, they went to see the cages that sheltered the wild animals; they saw elephants, lions, tigers, monkeys, giraffes and many more.

In the end of the tour the four friends made a picnic with their classmates, when they saw two men loading animals in to a truck. Each man carried a cage with four baby monkeys and each one made seven trips. (2)

The four friends decide to investigate, first they went to the guide that lead them on the trip and asked him:

- Mister Manuel, do you know that men that were carrying the baby monkeys?

- Yes, I know them, they are the animal handlers!

Daniel, Anthony, Bernard and Ann didn't believe the guide and decided to spy him and the other men. They went to the back of the truck and saw the guide talking with the other two men.

- Look out, there is a bunch of kids suspecting of us.

- Let's get out of here the faster we can. - Said one of the men.

They left behind the truck, before any of the three men saw them. Then they joined their class. Meanwhile, Bernard called the police station and told them what happened.

Fifteen minutes later, the police arrived in three cars and in each car there were three policemen that arrested the three men.

- In how many ways can the policemen carry the bandits? (3)

Their classmates started thinking in the problem, meanwhile, the teacher call them to get back to the bus.

And this way ended another adventure of these four friends.

Sardinha (2011), Group A, 2nd year of primary school

Resolution of the 1st problem posed

In the resolution of this problem, students have shown difficulties in calculating the distance of the trip due to the fact that it started at a quarter past eight and not at an exact hour. They also showed difficulties in relating one hour with half an hour and quarter of an hour. The teacher had to ask them to draw a watch so that they could represent and count the minutes. This strategy helped them to overcome their first difficulties. And they were able to calculate that they travelled for two hours and forty five minutes. But then they had to calculate how many kilometers they travelled, easily they realized that if in one hour they travelled one hundred kilometers, in two hours they would travel two hundred kilometers. In this moment a new problem arose since they experienced difficulties calculating the kilometers travelled in forty-five minutes. Once again, the watch was fundamental in this task, the teacher explored the division of the unit in equal parts and the representation of these quantities in the drawing. The goal was that students identified the concept of half, third part and quarter part and made connections between the kilometers travelled in an hour, half an hour and a quarter of an hour, so that they could finally reach the forty five minutes.

The students easily calculated the distance travelled in a half an hour but showed a lot of difficulties finding the distance travelled in a quarter of an hour. Only one student solved the problem without showing too many difficulties, while the others needed the help of the teacher to understand the reasoning in order to reach the solution.

As they do this, they also get more creative in the way they solve their own posed problems because, most of times, they don't have mathematical formal knowledge to solve what they pose. So, they have to apply their informal and formal mathematical knowledge in a creative way, during the process of verification, solving the problem they posed, to get to the solution allowing them to verify if the problem is correctly posed.

IMPLICATIONS OF THE WORK ON DIFFERENT COMMUNITIES

The work developed during these years has progressively permitted more knowledge and it peaked with the teacher training course and the creation of stories in the teachers' fourteen classes. It is interesting and important to stress that students were creating stories with problems that were intended to other students, which was part of the motivation.

During the construction of the problem stories, students have created tasks and tested them. They had to verify if the problems formulated had to be re-structured, so they had to solve them and use metacognitive strategies to recognize errors committed, and trying to overcome those errors. All the work was previously developed in a research setting but in the teacher training phase the task creation was performed in a more realistic setting. Students have shown real interest with the problem posing and solving, establishing an ownership relation with the work produced. We tried to convince teachers of the students' ability to develop significant mathematical tasks, sometimes with a degree of difficulty superior to the textbooks. At the same time, students developed their mathematical communication skills when presenting their work, the errors committed and the strategies used to overcome difficulties.

CONCLUSIONS

The set of tasks assembled by us, which constitutes the core of the methodology presented, permits that each teacher may create his or her tasks as long as some basic aspects are respected, concerning the type of tasks and the type of text created to involve the problem. At first students must contact with a story with a non-routine problem that may enlarge their encyclopaedic competency and their creativity. The teacher must be participant at the beginning, retreating to a more supervision role with time.

Problem stories permit students to, after experiencing the tasks proposed in the implementation of this methodology, create their own mathematical tasks. In the process, students develop literacy and numeracy competencies, metacognitive strategies, creativity and friendly relations with these two important areas of the curriculum. The fact that students have a very active role induces extra motivation and implies some reflection on their own learning. Sharing their problem stories with peers either from the class or the school invites to more sophistication and accrued difficulty on their subsequent creations. They resort to their literacy competences to try to mislead future solvers as a way to make problems more difficult.

From the adaptation of traditional stories, in which students vocabulary is enriched with teacher's help, students use their inter-textual reference frameworks not only to interpret texts but also to formulate problems. Students should formulate problems coherent with the story plot, and initially they probably use the recontextualization of problems solved previously but progressively they will tend to develop autonomy and will formulate their own problems. At the end, the opportunity to create problem stories allows them to create their own mathematical tasks, mobilizing the knowledge and competencies acquired in the process enhancing their creativity.

REFERENCES

Azevedo, F. (2009). Literacias: contextos e práticas [Literacies: contexts and practices]. In F. Azevedo, & M. G. Sardinha, *Modelos e práticas em literacia [Models and practices in literacy]* (pp.1-16). Lisboa: Lidel.

- Bush, W. S., & Fiala, A. (1993). Problem stories - A new twist on problem posing. In S. I. Brown e M. Walter, *Problem Posing - Reflections and Applications* (pp.167-173). New Jersey: Lawrence Erlbaum Associates.
- Cropley, A. (2006). In Praise of Convergent Thinking. *Creativity Research Journal*, 18(3), 391–404.
- Ervynck, G. (1991). Mathematical creativity. In D. Tall (Ed.), *Advanced mathematical thinking* (pp. 42–53). Dordrecht, Netherlands: Kluwer.
- Evans, C. W., Leija, A. J., & Falkner, T. R. (2001). *Math Links – Teaching the NCTM 2000 standards through children’s literature*. Colorado: Teacher Ideas Press.
- Goldenberg, E. P., & Walter, M. I. (2003). Problem posing as a tool for teaching mathematics. In H. L. Schoen (Ed.), *Teaching mathematics through problem solving: Grades 6 – 12* (pp.69-84). Reston, VA: National Council of Teachers of Mathematics.
- Guilford, J. P. (1967). *The nature of human intelligence*. McGraw-Hill: New York.
- Jay, E. S., & Perkins, D. N. (1997). Problem finding: The search for mechanism. In M. A. Runco (Ed.), *The creativity research handbook* (Vol. 1, pp. 257–293). Cresskill, NJ: Hampton Press.
- Kantowsky, M. G. (1977). Processes involved in mathematical problem solving. *Journal for Research in Mathematics Education*, 8, 163-180.
- Kilpatrick, J. (1987). Problem formulating: Where do good problems come from? In A. H. Schoenfeld (Ed.), *Cognitive science and mathematics education* (pp. 123–148). Mahwah, NJ: Lawrence Erlbaum.
- Krulik, S., & Rudnick, J. (1993). *Reasoning and problem solving - a handbook for elementary school teachers*. Massachusetts: Allyn and Bacon.
- Leikin, R., Berman, A., & Koichu, B. (2010). *Creativity in mathematics and the education of gifted students*. Rotterdam: Sense Publishers.
- Leung, S., & Silver, E. (1997). The role of task format, mathematics knowledge, and creativethinking on the arithmetic problem posing of prospective elementary school teachers. *Mathematics Education Research Journal*, 9(1), 5-24.
- Love, E., & Mason, J. (1992). *Teaching mathematics: action and awareness*. Southampton: Open University.
- Mann, E. L. (2006). Creativity: The essence of mathematics. *Journal for the Education of the Gifted*, 30, 236–262.
- Mayer, R. E. (1992). *Thinking, problem solving, cognition*. New York: Cambridge University.
- Mayer, R. E. (2002). Mathematical Problem Solving. In Royer, J.M. (Ed.) *Mathematical Cognition* (pp.69-92). Connecticut: Age Publishing.

- Palhares, P. (1997). Histórias com problemas construídas por futuros professores de matemática [Stories with problems constructed by future mathematics teachers]. In D. Fernandes, F. Lester, A. Borralho, & I. Vale, *Resolução de problemas na formação inicial de professores de matemática - múltiplos contextos e perspectivas* [Problem solving in the initial formation of mathematics teachers – multiple contexts and perspectives] (pp.159-188). Aveiro: GIRP.
- Polya, G. (1965). *Mathematical discovery, Volume II: On understanding, learning and teaching problem solving*. New York: Wiley.
- Sardinha, M. F. (2005). *Histórias com Problemas – Uma Forma de Educar para a Numeracia e para a Literacia* [Stories with problems – a way to educate for numeracy and literacy]. Tese de mestrado em Estudos da Criança – Área de Especialização em Ensino e Aprendizagem da Matemática, Braga: Universidade do Minho.
- Sardinha, F. (2011). *Histórias com Problemas e a sua ligação à promoção da numeracia e da literacia no 1.º Ciclo do Ensino Básico* [Stories with problems and their connection to numeracy and literacy in the 1st cycle of Basic Teaching]. Tese de doutoramento em Estudos da Criança – Especialidade de matemática elementar, Braga: Universidade do Minho.
- Torrance, E. P. (1974). *Torrance tests of creative thinking*. Bensenville, IL: Scholastic Testing Service.
- Vale, I. e Pimentel, T. (2004). Resolução de Problemas. In P. Palhares (Org.), *Elementos de Matemática para professores do Ensino Básico* (pp. 7-52). Lisboa: Lidel.
- Van Harpen, X. Y., & Sriraman, B. (2013). Creativity and mathematical problem posing: An analysis of high school students' mathematical problem posing in China and the USA. *Educational Studies in Mathematics*, 82(2), 201–221.

REVEALING THE INNER CONNECTIONS OF MATH USING A CLOCK PUZZLE

Sabine Stöcker-Segre

Davidson Institute of Science Education

sabine.segre@weizmann.ac.il

Teaching the inner context of math is important when teaching problem solving strategies and mathematical thinking rather than rules. Moreover, puzzles are by their nature very often more interesting than school book problems. We show a puzzle that was published on a free-access educational internet-site and several ways of solving it, all of them except for one submitted by users. Though the internet-site is not competitive in the sense of promising a prize, there is “moral” competition for submitting either the first or the better (i.e. more elegant) solution. The example given here can be solved with strategies coming from different fields of mathematics and can be used for showing that one should not look at the various mathematical disciplines as separated from each other, but as contributing to each other.

INTRODUCTION

It is well known that mathematical thinking can be trained with puzzles (Ervynck, 1991). Riddle forums, in particular, connect and enable fruitful discussions between individuals having very different educational background, which is a goal by itself (Usisking, 1994). Efforts should be made to teach mathematical thinking at schools rather than “recipes” to solve problems (Davis, 1988). In many countries this goal entered the program of math teaching as defined by the ministry of education. Room needs to be given to the various ideas of students, who will try to solve problems with very different techniques (Robinson, 1997). As a consequence, mathematical subjects cannot be treated as separated from each other, but as being interconnected and nourishing each other (Barabash, 2012). A successful teacher will not discard ideas, but fix them (if necessary) and show how they are connected to other ways of solution (Burton, 2004). In this paper we will present a mathematical puzzle which was presented on an internet site and solved in four different ways: algebraically, graphically, exploring symmetries and with infinite series. In the last section we will relate to the role of the forum manager and the importance of showing connections between the various ways of solution.

THEORETICAL BACKGROUND

Studies stress that the knowledge of mathematics is formed by representations (such as symbols, objects and pictures) which become interlinked with the progress of understanding (Hiebert & Carpenter, 1992). Solving mathematical problems triggers this formation of necessary links between representations, and thus contributes to the process of understanding (Freiman, Vézina, & Gandaho, 2005).

Depending on the techniques required to solve a particular problem, some mathematical problems are particularly suitable to create connections between representations. The following riddle is an example of a problem that fits to reveal connections between various mathematical fields. Solving it contributes to mathematical understanding as it reveals how various mathematical disciplines complete each other.

THE PUZZLE

The following puzzle was first presented in Hebrew on the “math circle”, a free-access educational internet site and rubric of “Davidson online”. Later the English translation was published, too. We refer here and in the following to the users’ messages and replies in Hebrew.

In its English translation the puzzle reads as follows (The Davidson Institute of Science Education affiliated to the Weizmann Institute of Science, 2012):

Usually, the long hand on the clock indicates the minutes and the short hand indicates the hours. If the minute hand did not exist, we would still be able to tell the time, because the hour hand moves continuously between the whole hours. For instance: at six thirty, the hour hand will be precisely between 6 and 7. What will happen if we swap the long hand with the short hand? In most cases the situation will be meaningless. For instance: when swapping the minute hand with the hour hand at 6:00, the minutes hand will point to 6 (meaning 30 minutes have lapsed from the whole hour) while the hour hand will point to 12 (a whole hour) – a situation which is not possible. However, at 1:46 (approximately) the two hands can be interchanged – the “new” time will be 9:09 (see figure 1).

How many positions are there on the clock that allow this sort of interchange of the hands?

This is not an easy riddle (and it is “homemade”, we don’t think it appears on the internet or in previously printed books). If it is too difficult for you, send us partial solutions and start a discussion.

Together with the text an illustration is shown:

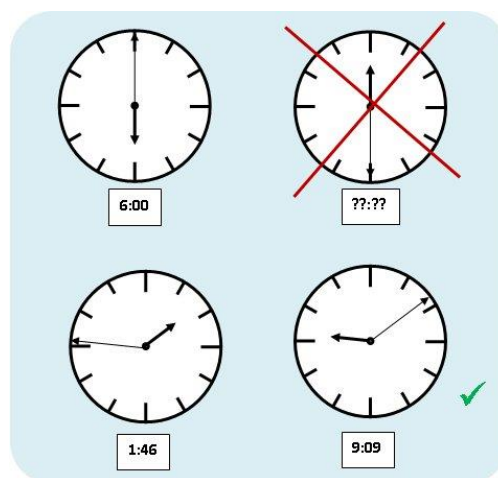

Figure 1. Illustration of the “Hands on the clock” riddle.

This puzzle can be solved in many different ways which will be presented in the following section. All except for the graphical solution have been sent by users to the puzzle forum. Many solutions were wrong on the first attempt, but fixing them delivered new insight into the problem. The graphical solution has probably not been submitted due to technical problems. Graphics can only be attached to a forum message, but cannot be displayed directly.

We did not ask for exact solutions, only for the number of solutions.

This riddle refers to a clock on which the hands move continuously (not jumping). This was clarified in the forum.

SOLUTIONS

There are 143 solutions: 11 solutions where both hands are in the same position (one on top of the other, like at 12 o'clock) and 66 pairs of two solutions where the time after the swap is different from the time before the swap (like the example in the second row of figure 1). We'll call the 11 solutions of overlapping hands "trivial solutions" and the two solutions of "swappable" positions "conjugated pairs". In figure 1, 1:46 and 9:09 are conjugated pairs. For convenience we describe positions in degrees as the angle between a hand and the 12 o'clock position. Because of the high divisibility of 360 we prefer in the context of the puzzle presented here to measure angles in degrees rather than in radian.

Algebraic Solution

We start with the algebraic solution since this solution reveals exact positions of the hands on the clock, not only the number of solutions. We will refer to the terminology of this solution when presenting the other solutions.

Let h indicate the hour and m the minutes in the case when the short hand points on the hours. Similarly, h' indicates the hour and m' the minutes in the case when the long hand points on the hours (after the swap).

$$0 \leq h < 12, \quad h \in \mathbb{N}, \quad 0 \leq m < 60, \quad m \in \mathbb{R}$$

$$0 \leq h' < 12, \quad h' \in \mathbb{N}, \quad 0 \leq m' < 60, \quad m' \in \mathbb{R}$$

For the angles in degrees between the hands and a vertically upward pointing axis (conventionally called the y-axis) the following equations are true (since each hand can be either the hour or minute hand):

$$30h + 0.5m = 6m'$$

$$30h' + 0.5m' = 6m$$

Resolving this set of equations with respect to m and m' yields after some manipulation:

$$m' = \frac{60}{143} (12h + h')$$

$$m = \frac{60}{143} (12h' + h)$$

This equation can be solved for all valid combinations of h and h' (each value an integer number between 0 and 11). The number of solutions is $12 \cdot 12 - 1$, since $h=h'=11$ yields $m'=60$ which is not a (new) solution. We required $m' < 60$.

We can verify this solution with a spreadsheet, see that in each line, i.e. for each combination of h and h' , the position of m in degrees (6th column) is equal to the position of h' (7th column), and the position of m' in degrees (last column) is equal to the position of h (5th column). Thus, we can read the angles of the “swappable” positions in degrees from the table. The solution displayed as an example in figure 1 appears in row 9 (for $h=1$ and $h'=9$) and is marked in yellow. Obviously, the position of the hour hand h before the swap (5th column) is the same as the position of the minute hand m' after the swap (last column). The pairs (h, h') and (h', h) are conjugated pairs, referring to the same solution before and after the swap.

Table 1. A spreadsheet program displaying hours, minutes and angles of swappable positions.

h	h'	m	m'	position of h in degrees	position of m in degrees	position of h' in degrees	position of m' in degrees
0	0		0	0.00	0.00	0.00	0.00
0	1	5	5/143	60/143	2.52	30.21	2.52
0	2	10	10/143	120/143	5.03	60.42	5.03
...							
1	0		60/143	5	5/143	30.21	2.52
1	1	5	5/11	5	5/11	32.73	32.73
...							
1	9	45	105/143	8	116/143	52.87	274.41
...							
2	0		120/143	10	10/143	60.42	5.03
2	1	5	125/143	10	70/143	62.94	35.24
2	2	10	10/11	10	10/11	65.45	65.45
...							
5	5	27	3/11	27	3/11	163.64	163.64
...							
11	10	54	138/143	59	83/143	357.48	329.79
11	11		60	60		360.00	360.00

Graphical solution

We refer first to a simplified and classical problem: At what hours do the two hands of a clock (indicating hours and minutes) point exactly into the same direction?

We can solve this problem graphically:

On the y-axis we note angles in degrees from 0° to 360° , on the x-axis time in hours.

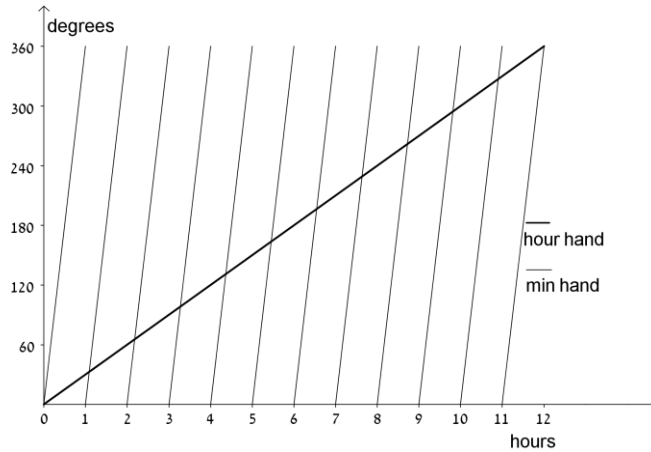

Figure 2. When do the two hands of a clock point exactly in the same direction? The thick line describes the movement of the hour hand, the thin lines the movement of the minute hand during 12 hours.

The minute hand (12 thin lines in the illustration above) completes 12 circles during 12 hours; the hour hand completes one circle (one thick line only in the graph). At the points of intersections of the thin lines with the thick line both hands point exactly in the same direction. There are 11 points of intersection (not counting 00:00 and 12:00 twice), i.e. 11 times during 12 hours both hands point exactly in the same direction (one being on top of the other). These are the “trivial solutions” of the swappable position puzzle.

To find more than the trivial solutions, we note that the hour hand will become the minute hand after the swap. To let the thick line of figure 2 describe the minute instead of the hour hand, we need to change the scale on the x-axis: it will now run from 0 to 60 minutes. Next, we need to draw new lines for the new hour hand. These are the dashed blue lines of figure 3.

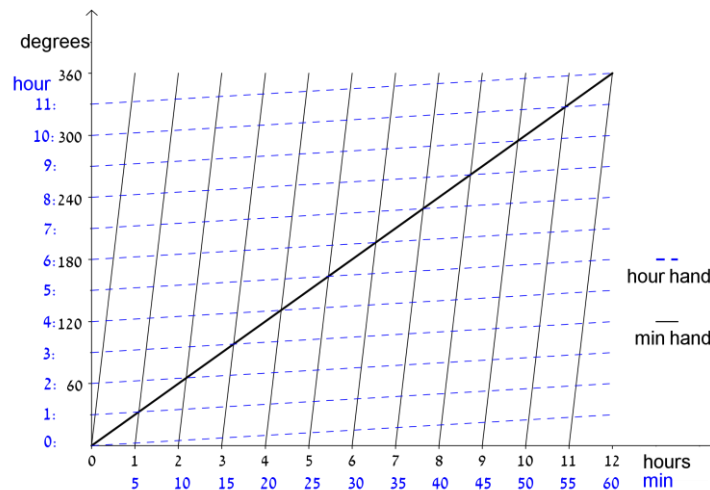

Figure 3. When the thick line describes the movement of the minute hand, we need to refer to the blue scale, and the dashed blue lines describe the movement of the hour hand. When the thick line describes the movement of the hour hand, we refer to the black scale, and the thin black lines describe the movement of the minute hand. The points of intersection indicate swappable positions.

Figure 3 has two scales – one is relevant when the thick line describes the hour hand, the other one when the thick line describes the minute hand.

Given a certain value on the y-axis (the angle between a hand and the 12 o'clock position) we draw a parallel line to the x-axis. Where this line intersects the blue dashed line, the position that we chose on the y-axis is the position of the hour hand, and the hour can be determined by reading the full hour from the blue scale on the y-axis and the minutes from the blue scale on the x-axis (6:30 in the example of figure 4).

Where a line parallel to the x-axis intersects thin black lines, the position that we chose on the y-axis is a position of the minute hand, and the hour can be read from the black scale on the x-axis. There are 12 points of intersection and therefore 12 options of reading the time, since the minute hand can determine the minute only, but not the hour.

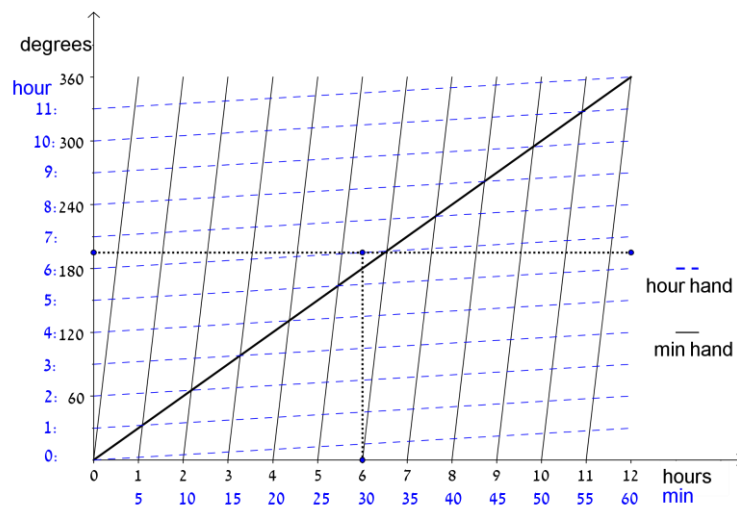

Figure 4. Given the angle between a hand and the 12 o'clock position (on the y-axis), the hour can be determined by means of the dashed blue lines, when it is the hour hand, and by means of the thin black lines, when it is the minute hand.

Where the thin black lines intersect the dashed blue lines, the position (as indicated in degrees on the y-axis) can be interpreted as the position of the hour hand as well as the position of the minute hand. In either case the thick black describes the movement of the remaining hand throughout sixty minutes or 12 hours, respectively. These positions are therefore swappable. We count 143 points of intersection, not counting the points at 00:00 and 12:00 twice.

This graphical solution reveals the number of solutions only, unless we write the equations for the lines referred to above, and look for the points of intersection algebraically.

Solution exploring symmetries

Obviously, swappable positions are symmetric in a certain way. What is or what are the axes of symmetry? These are the trivial solutions as will follow from the following approach:

Divide the circle into 13 sectors, such that one line of division coincides with the 12 o'clock position. Here and in the following we call the 13 radii which divide the circle into 13 sectors "division lines". Counting the division lines in a clockwise sense, the 12 o'clock position is the 13th division line (see the figure below). Starting at 12 o'clock, at the time the hour hand has moved through X sectors, it is on the X^{th} division line. At this time, the minute hand has moved through $12X$ sectors (since it moves 12 times as fast as the hour hand) and will be on division line number $13 - X$:

$$12X \bmod 13 = (13 - 1)X \bmod 13 = 13 - X.$$

This position (the hour hand at division line number X , the minute hand at $13 - X$) is swappable: if the hour hand will be at $X' = 13 - X$, the minute hand will be at $13 - X' = X$.

This division of the circle into 13 equal sized sectors can be repeated 11 times: each time one of the division lines coincides with one of the 11 trivial solutions. That way we receive $11 \times 13 = 143$ solutions.

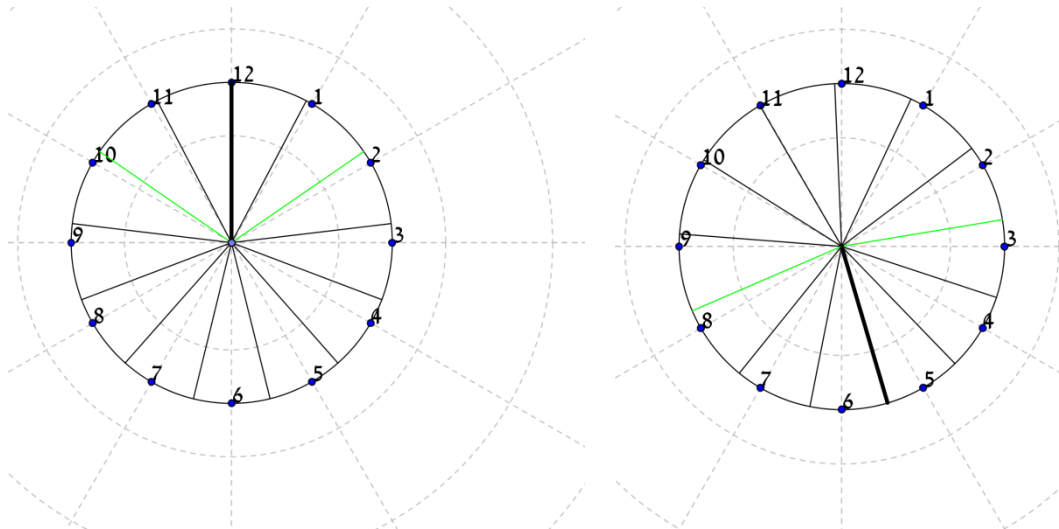

Figure 5. Division of the circle into 13 sectors, such that one of the division lines coincides with a trivial solution; this is on the left the 12 o'clock position, and on the right the emphasized line in the 5:27 position. Lines which are at equal distance (to the left and to the right) from the emphasized line indicate swappable positions, i.e. before the switch the minute hand will be in one of these two positions and the hour hand in the other one, and after the switch it will be the other way around. Examples for swappable positions are marked in green.

Swappable positions are at the same distance (counting sectors clockwise and counter-clockwise) from the trivial solution division line. In other words – a trivial-solution-

division line is the bisector (or axis of symmetry) of the angle formed by swappable positions.

The symmetry of solutions can be seen in the graphical approach, too: each conjugated pair of solutions (one member in the upper left of the graph in figure 3, the other member in the lower right) is symmetric to the line through the trivial solutions.

To confront the symmetry-approach solution with the algebraic solution, we enumerate the algebraic solutions for (h, h') with $0 \leq h < 12$ and $0 \leq h' < 12$ with n running from 1 to 143 in the following way

$$n = 12h + h' + 1$$

We receive 11 subsets of 13 solutions based on the division of the circle into 13 sectors.

Each subset is characterized by one solution where the two hands are one on top of the other ($h = h'$), and 12 further solutions, with an angle of $360^\circ/13$ between neighbours, or, when referring to the enumerated solutions, a difference of $\Delta n = 11$ between two consecutive solutions. See in the following two tables two subsets, one for $h = h' = 0$ and the other one for $h = h' = 5$.

n	1	12	23	34	45	56	67	78	89	100	111	122	133
(h,h')	(0,0)	(0,11)	(1,10)	(2,9)	(3,8)	(4,7)	(5,6)	(6,5)	(7,4)	(8,3)	(9,2)	(10,1)	(11,0)

n	66	77	88	99	110	121	132	143	11	22	33	44	55
(h,h')	(5,5)	(6,4)	(7,3)	(8,2)	(9,1)	(10,0)	(10,11)	(11,10)	(0,10)	(1,9)	(2,8)	(3,7)	(4,6)

The solutions of subset i ($i \in \{1, \dots, 11\}$) have numbers

$$n = i + 11j, \quad j \in \{0, \dots, 12\}.$$

Infinite series solution

This solution is iterative. We will calculate the time that elapses between two swappable positions and, starting from a first approximation, five minutes after noon, subsequently “adjust” the minute and the hour hand. Each time we subsequently fix both hands, we add $1/12^2$ of the time interval we previously added for fixing both hands (as will be shown in the following). Therefore, the time interval that passes until the next swappable position is

$$\Delta t = 5(1 + 1/12^2 + 1/12^4 + 1/12^6 + 1/12^8 + \dots). \tag{1}$$

This is a geometric series that sums up to

$$\Delta t = 5 \frac{1}{1 - 1/12^2} = 5(144/143).$$

The method can be applied to all positions that have been demonstrated to be swappable. Thus, the time interval that passes between two subsequent swappable

positions is constant and equal to $5 \left(\frac{144}{143} \right)$ minutes. Therefore there are 143 such positions during 12 hours.

In the following we will derive the geometric series as it appears in equation (1).

The idea is to fix at each iteration step subsequently the long and the short hand. Since the hour hand moves with $1/12$ of the velocity of the minute hand, and since both hands can be either minute or hour hand, the correction to the first approximate interval between swappable positions contracts at each iteration step twice by a factor of $1/12$, i.e. at each iteration step by a factor of $1/12^2$.

We point out that the (short) hour hand moves with an angular velocity of $0.5^\circ/min$ and the (long) minute hand with an angular velocity of $6^\circ/min$ which is 12 times as fast as the hour hand. We are going to calculate the time t between two subsequent swappable positions. Each iteration step is split into two, in which the two hands of the clock will be subsequently “fixed”. Therefore all angles α and times t carry two indices, the first one (i) indicating the iteration step ($i \geq 1$) and the second one (j) the sub-step ($j=1$ or 2). The sequence of iterating angles and times (being proportional one to the other) reads $\alpha_{1,1}, \alpha_{1,2}, \alpha_{2,1}, \alpha_{2,2}, \alpha_{3,1}, \alpha_{3,2} \dots$ and $t_{1,1}, t_{1,2}, t_{2,1}, t_{2,2}, t_{3,1}, \dots$. The first sub-step of each iteration ($j = 1$) occurs around the 12 o’ clock position, and the second sub-step ($j=2$) around the one o’ clock position.

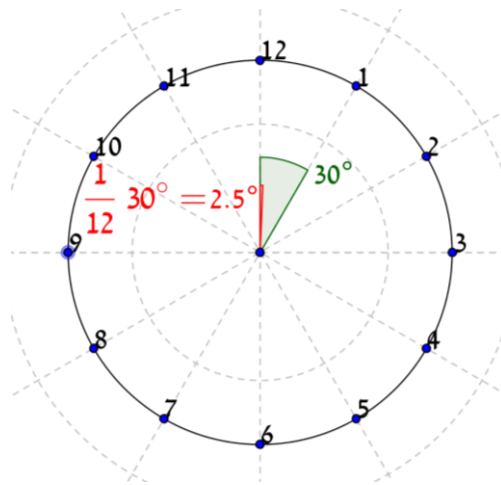

Figure 6. The hour hand moves with $1/12$ of the angular velocity of the minute hand.

- 1) Let’s start for easiness at 12 o’ clock sharp, where both hands of the clock are one on top of the other ($\alpha_{1,1} = 0^\circ, t_{1,1} = 0$). The argument works for all positions of which we already know that the hands of the clock can be swapped.
- 2) Since the short hand, which is actually the hour hand, points on 12, it will point on “0 minutes” after the swap. Therefore we expect in a first approximation the next position where the hands can be swapped at 12:05: here the (long) minute hand, which will be the hour hand after the swap, points on 1 (the next full

hour). Pointing on 1, it forms an angle of $\alpha_{1,2} = 30^\circ$ with the 12 o' clock position. In the end of the initial iteration step ($i = 1, j = 2$), $\alpha_{i,2} = \alpha_{1,2} = 30^\circ$ and $t_{i,2} = t_{1,2} = 30^\circ / (6^\circ/\text{min}) = 5 \text{ min}$.

- 3) Since the minute hand has moved for 5 minutes, the (short) hour hand has moved, too, with 1/12 of the velocity of the minute hand. In the next iteration step it will therefore form an angle of $30^\circ / 12 = 2.5^\circ$ with the 12 o' clock position. (In general terms: in the first sub-step of the following iteration we add an angle of $\alpha_{i+1,1} = \alpha_{i,2} / 12$.)
- 4) The (original) hour hand will become the (new) minute hand after the swap. In its current position it forms an angle of 2.5° with the 12 o' clock position. A minute hand moves with $6^\circ/\text{min}$. The position 2.5° will be translated to pointing on $2.5/6 = 5/12$ minutes after the full hour. In general terms: the first sub-step of this iteration yields a time-interval of $t_{i+1,1} = 1/12 \cdot t_{i,2}$.
- 5) The (long) minute hand, which will become the hour hand, should not point anymore on 1 o'clock sharp, but on a position where as hour hand it will point on 5/12 minutes after 1 o'clock. Since the hour hand moves with a velocity of 1/12 of the minute hand, this will be at 1/12 of 2.5° after the 1 o'clock position, or at 1/12 of 5/12 minutes after the "5 minutes after noon position" (referring to the minute scale on the watch). In general terms: the second sub-step of the iteration yields a time-interval of

$$t_{i+1,2} = 1/12 \cdot t_{i+1,1} = 1/12^2 t_{i,2}, \text{ or briefly (omitting the index of the sub-steps), } t_{i+1} = 1/12^2 t_i.$$

- 6) Now the iteration steps 3 to 5 have to be repeated to infinity. The time interval that elapses between two subsequent swappable positions sums up to

$$\Delta t = 5 + 5/12^2 + 5/12^4 + \dots$$

as in equation (1).

DISCUSSION

The approaches to finding the solutions demonstrated above differ from each other very much: algebraic, graphical, exploring symmetries and making use of infinite series.

It is important to mention that

- the forum manager did not provide any of the above mentioned solutions.
- none of the solutions that were uploaded to the forum were correct on the first attempt.

On the first attempt, the algebraic approach did not lead to equations that could be solved easily, since it was formulated with the modulus instead of limiting the interval of minutes to $0 \leq m < 60$ and the interval of hours to $0 \leq h < 12$.

The infinite series approach was stopped after two iterations and not carried out to the end.

The approach making use of symmetries divided the circle only once (and not 11 times) into 13 sectors. The user thought only of the solution where one division line coincides with the 12 o' clock position, but did not consider that a division line can coincide with other trivial solutions.

The fact that the graphical solution did not appear in the forum shows a limit of posing riddles in puzzle forums. It limits communication about the visual problem-solving approach, which is certainly of importance (Giaquinto, 2007) (English, 1997).

The solution which argues with symmetries (the third solution in the previous section) is outstanding in the sense that the approach is contra-intuitive, leaving common ways of thinking, as very often required in problem solving ("the egg of Colombo"): instead of dividing the circle into 12 sectors (as we are used to) it is divided into 13 sectors (adding the movement of the hour hand to the movement of the minute hand).

Following these observations we'd like to suggest a few guidelines for math teachers, forum managers and riddle posers:

- Wrong solutions should not be discarded, but fixed (Schoenfeld, 1994).
- The forum manger should not provide solutions.
- The role of the forum manger is to unveil hidden connections between the various ways of the solution and mention that big achievements in mathematics were reached by carrying problems to other sub-disciplines of math (Singh & Lynch, 1998).

ACKNOWLEDGEMENTS

I'd like to thank the visitors of the math circle for inspiring messages and the solutions presented here, Enrico Segre for the graphical solution, Dan Blat for Hebrew-English translations of internet material, and Marita Barabash for drawing my attention to the field of "the context of math and math in context". All graphs were made with "Geogebra".

REFERENCES

- Barabash, M. (2012). *Mathematics: Teaching in context, teaching the context* (in Hebrew). Tel Aviv: Mofet.
- Burton, L. (2004). *Mathematicians as enquirers*. Boston: Kluwer Academic Publishers.
- Davis, R. B. (1988). The interplay of algebra, geometry and logic. *Journal of Mathematical Behaviour*, 7, 9-28.

- English, L. D. (1997). Analogies, metaphors, and images: vehicles for mathematical reasoning. In L. D. English, *Mathematical reasoning: analogies, metaphors, and images. Studies in Mathematical Thinking and Learning*. (pp. 3-18). Mahwah: Lawrence Erlbaum Associates.
- Ervynck, G. (1991). Mathematical creativity. In D. Tall, *Advanced mathematical thinking* (pp. 42-53). Dordrecht, the Netherlands: Kluwer.
- Freiman, V., Vézina, N., & Gandaho, I. (2005). New Brunswick pre-service teachers communicate with schoolchildren about mathematical problems: CAMI project. *ZDM The International Journal of Mathematics Education*, 178-189.
- Giaquinto, M. (2007). *Visual thinking in mathematics. An epistemological study*. Oxford: Oxford University Press.
- Hiebert, J., & Carpenter, T. (1992). Learning and teaching with understanding. In D. A. Grouws, *Handbook of Research on Mathematics Teaching and Learning* (pp. 65-97). New York: Macmillan.
- Robinson, J. A. (1997). Informal rigor and mathematical understanding. *Computational logic and proof theory. Lecture Notes in Computational Sciences*, vol. 1289, 54-64.
- Schoenfeld, A. H. (1994). Reflections on doing and teaching mathematics. *Mathematical thinking and problem solving*, Stud. Math. Think. Learn. 53-75 Erlbaum Hillsdale, NJ.
- Singh, S., & Lynch, J. (1998). *Fermat's Enigma: The Epic Quest to Solve the World's Greatest Mathematical Problem*. Anchor.
- The Davidson Institute of Science Education affiliated to the Weizmann Institute of Science. (2012, December). *Riddle #2: Hands on the clock!* <http://davidson.weizmann.ac.il/en/online/mathcircle/puzzles/riddle-2-hands-clock>
- Usiskin, Z. (1994). From “Mathematics for some” to “Mathematics for all”. In R. Biehler, R. W. Scholz, R. Strasser, & B. Winkelmann (Eds.), *Didactics of mathematics as scientific discipline* (pp. 315-326). Dordrecht, the Netherlands: Kluwer.

MATHEMATICAL CREATIVITY THROUGH THE EYES OF FUTURE TEACHERS

Isabel Vale, Ana Barbosa, Lina Fonseca

School of Education of the Polytechnic Institute of Viana do Castelo, Portugal

isabel.vale@ese.ipvvc.pt, anabarbosa@ese.ipvvc.pt, linafonseca@ese.ipvvc.pt

Creativity plays an important role nowadays in mathematics education, being a dynamic characteristic that students can develop if teachers provide them appropriate learning opportunities. Based on this assumption, it is important to understand what future elementary school teachers think about creativity and how they deal with that perception when they solve challenging tasks. The participants in this study were sixty-three students of three master courses in teacher education in the beginning of their courses. Data collection included a questionnaire, with some questions and two tasks to solve about creativity, and an interview to a focus group. The findings provided insights supporting that future teachers are confident to develop creativity with their students and it was possible to identify that they also have some characteristics related to creativity.

INTRODUCTION

Nowadays innovation is seen as increasingly important for the development of the 21st century knowledge society. Our challenge as teacher educators is to find solutions for developing creative and innovative education, as a means to foster creative competences and innovative skills among the next generation. So we must teach for creativity. Teachers are the main vehicle for doing this because they have the power to unlock the creative, innovative and critical potential of young students. If we believe that learning mathematics is strongly dependent on the teacher and creativity is connected with problem solving and problem posing, it is necessary, thus, to offer pre-service teachers diverse experiences, in order to develop their problem solving skills, not only throughout their teaching practice, but also so that they can take advantage of mathematics over their lives, mainly in facing the challenges of a competitive and global world.

FUTURE TEACHERS AND MATHEMATICAL CREATIVITY

It is widely recognized that teachers play an essential role in the process of teaching and learning, not only what the teacher knows, but the way he/she uses that knowledge and how it works in the classroom. Thus, pre-service teachers need to learn both mathematics and how to teach it (Oliveira & Hannula, 2007). In order to understand and explain mathematical concepts, and also to provide connections and rationale behind mathematical relationships, teachers need a profound understanding of the subject they teach (Ma, 1999). However, teachers need more. Not only knowledge, in

the sense highlighted by Shulman, but also important are the perspectives of teachers about the teaching and learning process and some personal characteristics related to knowledge. Hannula (2011) refers that affective issues are important in mathematics education; in particular he says that when we investigate creativity, genuine problem solving, proof and other higher-level cognitive processes, we see that cognition is intrinsically intertwined with emotions. However, he says that those processes are complex and we do not yet understand them well enough.

Research suggests that teachers' beliefs influence their classroom practices, considering that beliefs can be perceived by what people say or do, by their behaviours, attitudes, values and they hold great influence in the perceptions people have about the world (Pajares, 1992). However, it is possible that over time these ideas may evolve due to the teacher training courses they attend, since the experiences they have as students and in practice contexts help shaping new beliefs.

Teacher efficacy is also important in classroom management. It includes beliefs about whether an individual teacher can make a difference with his/her students (personal teacher efficacy). The efficacy is linked to the teacher's degree of confidence. Confidence is considered here in the sense given by Burton (2004), that is a label for a confluence of feelings relating to beliefs about the self, and about one's efficacy to act within a social setting, in this case the mathematics classroom. Graven (2004) has theorized that confidence is both a result of learning (e.g. successful learning leads to increased confidence) and also a process (e.g. confidence contributes to learning). This author expressed that confidence was relevant to the teachers' ability to approach mathematical activity and to see themselves as proficient teachers of mathematics. This confidence of the teacher is a result of his learning and of the explanation of that learning. Graven further argued that there is a close and positive relationship between confidence of teachers and the improvement of their mathematical knowledge, which leads to a better teaching.

Some subjects are frequently seen as offering fewer opportunities to promote creativity than others. Normally, mathematics is included in this group of subjects. This is why Bolden, Harries and Newton (2010) consider important to discuss with pre-service teachers their beliefs about creativity in mathematics, trying to perceive how these ideas impact their teaching strategies and translate into classroom practice. In this sense, it is not enough that teachers know the general meaning of creativity, but understand that the dimensions or characteristics of creativity can vary with the subject and the context they are dealing with. It is crucial that pre-service teacher training promotes reflection about this issue.

The teacher has great responsibility in the way mathematics is taught and learned, so he/she is the key to foster creative thinking in the classroom. The beliefs and perceptions of an individual on a particular idea are reflected in his actions and behaviours, so it can be stated that teachers' beliefs about mathematical creativity significantly influence the activity of their students in the classroom. Besides knowing

the general meaning of creativity, teachers must realize that it varies with the subject and the context in which it occurs (Aiken, 1973; Haylock, 1997; Varygiannes, 2013).

What students learn is largely influenced by the tasks used in the classroom, that provide the starting point for the mathematical activity of students and its implementation determines its cognitive level. Teachers can create some problematic situations for very specific purposes, and allow others to arise in a less planned manner. Mathematical challenging tasks are not just difficult tasks or with a higher level of mathematization, but much of the challenge may be provided by the teacher (e.g. Stein & Smith, 1998; Vale & Pimentel, 2011). So, teachers should carefully plan what they want to work on and what cognitive challenges they wish to provide their students. Teachers also must decide what aspects of a task to highlight, how to organize and orchestrate the work of the students, what questions to ask to challenge those with varied levels of expertise, and how to support students without taking over the process of thinking for them and thus eliminating the challenge, in particular when they explore problem solving tasks (Vale, Pimentel, Cabrita, Barbosa & Fonseca, 2012). In this study, we privileged challenging tasks, those that are interesting, even enjoyable for the solver, and often involve conjecturing, multiple approaches and/or multiple solutions and are mainly related to problem solving and problem posing.

Creativity begins with curiosity and engages students in exploration and experimentation tasks where they can manifest their imagination and originality (Barbeau & Taylor, 2005). Research findings show that mathematical problem solving and problem posing are closely related to creativity (e.g. Pehkonen, 1997; Silver, 1997). Mann (2006), in an examination of the research about how to define mathematical creativity, found that there is a lack of an accepted definition for mathematical creativity since there are numerous ways to express it. However, we can identify three components/dimensions of creativity: fluency, flexibility and originality. *Fluency* is the ability to generate a great number of ideas and refers to the continuity of those ideas, flow of associations, and use of basic knowledge. *Flexibility* is the ability to produce different categories or perceptions whereby there is a variety of different ideas about the same problem or thing. It reflects when students show the capacity of changing ideas among solutions. *Originality* is the ability to create fresh, unique, unusual, totally new, or extremely different ideas or products. It refers to a unique way of thinking. With regard to mathematics classrooms, originality may be manifested when a student analyses many solutions to a problem, methods or answers, and then creates another one different (e.g. Silver, 1997; Vale et al., 2012).

Taking into matter all the aspects previously discussed, the goals embedded within mathematics courses must include developing positive beliefs and attitudes, improving knowledge, self-confidence and abilities about mathematics, in particular, about creativity with pre-service teachers.

METHODOLOGY

Our main project, that involved pre-service, in-service and post-graduate levels in professional contexts and students of K-6 grade levels, had as main concern: to increase mathematical understanding and ability, through the development of elementary students' creativity and to devise ways of improving teacher practice. In particular, this research project addresses the teaching and learning of mathematics in different contexts, including teacher education, striving to: 1) develop a characterization of the population under study towards creativity, as a starting point and as outputs for further study; 2) identify/construct good tasks for mathematics classrooms towards the development of mathematics creativity. As we expect to get a deep understanding of the phenomena, our research approach was mainly qualitative and interpretive, following two main questions: Q1) What do future elementary teachers think about creativity?; Q2) How do the productions of these future teachers reveal some dimensions of creativity? For this particular paper the participants were 63 students of three master courses in teacher education at the beginning of their courses: 24 students of the Preschool Education Master Course (MEPE); 21 students of the Preschool Education and 1st cycle of Elementary Education Master Course (MPrePri); and 18 students of the 1st and 2nd cycles of Elementary Education Master Course (M1,2).

To collect data we used a questionnaire about creativity, including two tasks, and an interview to a focus group. The main results arose from a qualitative analysis. This focus group integrated six students, two of each course, whose selection was based on the responses to the questionnaire, on creative solutions of the tasks and on the need to clarify some ideas. We analysed the data from the questionnaire through categories that emerged from the responses of the students and the main questions we followed. The major difficulty was to measure creativity but, despite being uncomfortable with a psychometric evaluation, we do not have yet another alternative. So we analysed the tasks through the dimensions of creativity as following): *fluency*, measured by the number of correct responses, solutions, obtained by the student to the same task; *flexibility*, measured with the number of different solutions that the student can produce organized in different categories, whereby there is a variety of different ideas about the same situation; and *originality*, measured as the statistical infrequency of responses in relation to peer group responses (Conway, 1999; Silver,1997; Vale et al., 2012).

RESULTS

The questionnaire

In the first part of the questionnaire we tried to understand the beliefs/perspectives of the participants about creativity in mathematics, in the beginning of their courses. To do so, we formulated some questions, centred on the topic under study (creativity), in which the students had to express their opinion, stating if they agreed, disagreed or had no opinion. The issues examined in this study were: 1) Am I creative?; 2) Is creativity a rare gift that only a few have?; 3) Does creativity vary with age?; 4) Is creativity an individual characteristic?; 5) Can creativity be built collectively?; 6) Can creativity be

developed in most people if they are given that opportunity?; 7) Is it possible to assess students' creativity?; and 8) Can you teach and/or learn to be creative in mathematics? The answers were categorized according to the previously listed issues, being organized and presented in a chart. As can be seen in Figures 1, 2 and 3, we chose to present the answers of the students from each master course separately, in order to more easily highlight relevant differences and similarities.

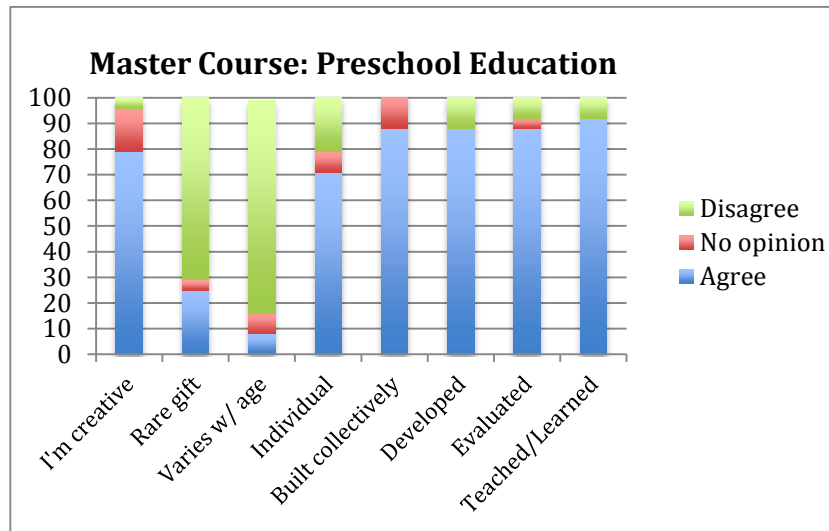

Figure 1. Answers of the students of the MEPE course (%).

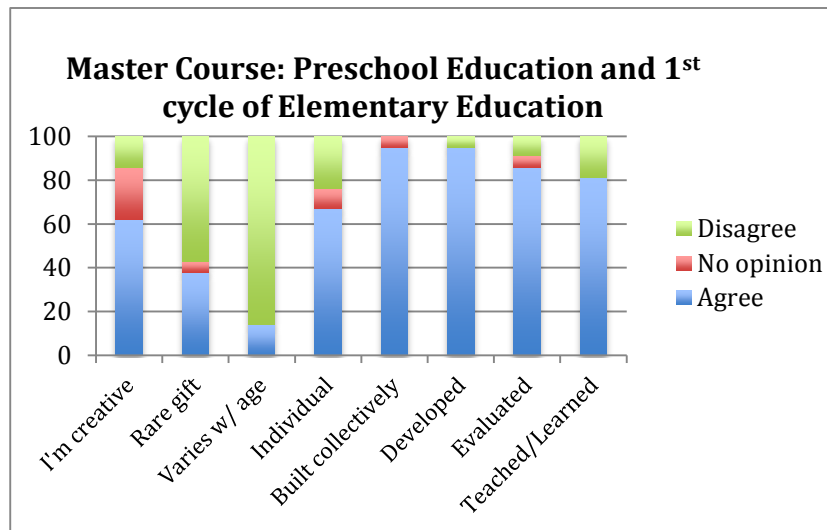

Figure 2. Answers of the students of the MPrePri course (%).

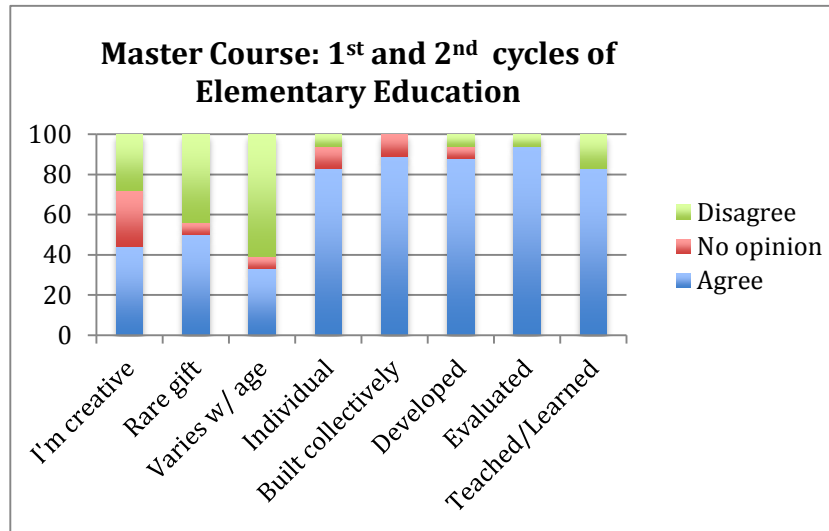

Figure 3. Answers of the students of the M1,2 course (%).

Based on the focused questions, we can organise three wider categories related to: intrinsic aspects of creativity (questions 1, 2 and 3); construction/development of creativity (questions 4 and 5); creativity in the teaching/learning process (questions 6, 7 and 8).

In the first set of questions we began to analyse the perspectives of students about their perceived ability to be creative. It appears that the students of MEPE consider themselves to be the most creative (79%), followed by those of MPrePri (62 %). In the case of students of M1,2, less than half acknowledge having this ability (44%). Most students of MEPE (71%) and MPrePri (57%) do not consider that creativity is a rare gift, contrary to the course of M1,2, where half of the students highlighted that not all people are born with this ability, thus reinforcing the difficulty in being creative, as they pointed in the answers to the previous question. Regarding the relationship between creativity and age, we identify again some differences between students in the three courses, with a greater proximity between the perspectives evidenced in the courses MEPE and MPrePri. In this item there is a higher percentage of students of M1,2 mentioning that creativity varies with age (33%) than in the other two courses.

Analysing the construction/development of creativity as an individual and collective activity, it is notorious, in the three master courses, that students, despite identifying creativity as an individual characteristic, mainly believe that it can be built collectively. The biggest difference between these two items is visible in the MPrePri course. It is relevant to note that no student disagreed that creativity can be built collectively.

The last three questions point aspects related to the process of teaching and learning with a focus on creativity. The vast majority of students in all three courses agreed that this ability can be developed in students, if given the opportunity. Likewise, they consider it likely to be evaluated, presenting, as in the previous question, very close opinions. Finally, we stress the agreement of the majority of the students in all three

master courses about the possibility of teaching and/or learning to be creative in mathematics; it is evident, however, a higher percentage of responses in MEPE (92%), compared to MPrePri (81%) and M1,2 (83%).

The tasks

The two tasks of the questionnaire were related to problem posing and problem solving (Figure 4). We analysed in detail the second task for two reasons: students presented more rich productions and we are limited to the number of pages of this paper.

Task 1



Task 2

Inês's cat tore the sequence of figures that she had prepared for class, leaving her only with the 2nd figure. Imagine that you are Inês and you have to reconstruct the sequence that had four figures. Draw as many different sequences as you can imagine, starting by drawing figure 1.

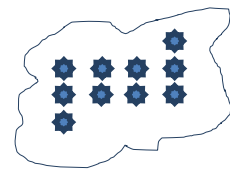

What is the question?

Figure 4. The two tasks.

In each master course we analysed the productions related to the first task. The most common proposals followed the same structure, related to one or more step problems, and involving the context of numbers and operations. These problems required additions and/or subtractions and referred to candies, flowers, money, clothes, etc. A geometric context appeared only in two cases, having the students of the courses M1,2 and MPrePri, referred to quantities and measures associated with the perimeter of a rectangle. In all courses proposals involving direct calculation also emerged, for example, $3+15-13$, but only a few students from M1,2 mentioned mental calculation. The most original proposals also appeared in the M1,2 course, where two students presented original problems, one of them involving inverse proportionality and the other a figure to count squares (Figure 5).

Rodrigo decided to plant apple trees on his land. How many squares could be counted in the figure?
 Alone he planted 5 apple trees in 20 minutes. If he had the help of 3 more friends, how long would it take to plant the 5 apple trees?



Figure 5. The most original responses.

Analysing the productions of the students from the three master courses when solving the second task, we observed 20 different sequences that included the given figure in the second position. The most frequent sequences presented by these students were the following:

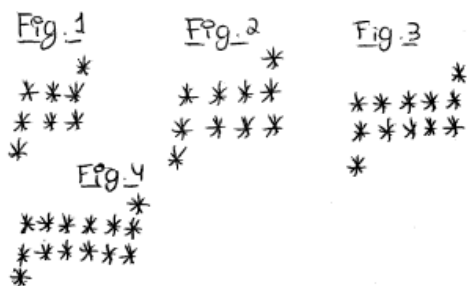

Figure 6. Sequence A.

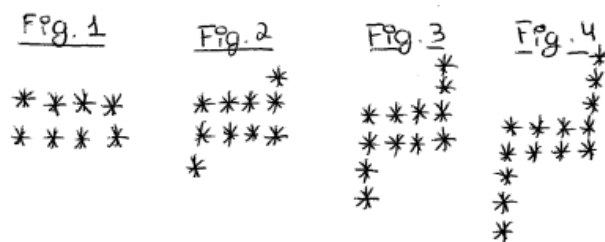

Figure 7. Sequence B.

Sequence A was mainly referred in the MPrePri and M1,2 courses and sequence B by the MEPE students. Sequence A maintains two columns of 3 stars, one in the left and one in the right, increasing the number of central columns, always with two stars in each, depending on the term of the sequence. In the first figure one column, in the second two columns, and so forth. Sequence B maintains the central body of stars, represented by a rectangle with 2 lines each with 4 stars, to which are added stars in the extremities. These stars vary with the number of the term minus one. In the first figure with zero stars, in the second figure with one star on each side, in the third figure with two stars in each side, and so on.

Taking as reference the dimensions of creativity - fluency, flexibility and originality - we can characterize students' productions. Regarding fluency, we've organized students' productions in levels, NU, 1, 2, 3, 4 and 5, respectively, if they did not answer the question or had no understandable work, presented one, two, three, four or five different sequences, which included the given figure as second term (Table 1).

Table 1. Number of different sequences presented by the students (fluency).

Nº of different sequences presented	MEPE n=24(%)	MPrePri n=21(%)	M1,2 n=18(%)
NU	8 (33,4)	2 (9,5)	0
1	6 (25)	8 (38,2)	7 (38,8)
2	6 (25)	4 (19)	9 (50)
3	2 (8,3)	4 (19)	2 (11,2)
4	2 (8,3)	2 (9,5)	0
5	0	1 (4,8)	0

A large number of students from MEPE either presented sequences that did not integrate the given figure, or where it was not explicit how they obtained the following term. If fluency is considered as the ability to display two or more different ways to build a sequence, integrating the given figure as the second term, the M1,2 students were the most fluent (61,2%), however in the other two master courses a reduced number of students were able to present 4 or 5 different sequences. If we focus on the

number of students who presented three or more different ways to create a sequence, this number decreases substantially in the three courses.

Regarding the originality of the answers (Table 2), it stands out, in each course, that a few students showed it. In this assessment we consider original the productions submitted by only one or two students in the respective course. So, originality is measured within these particular contexts and based on the answers students gave.

Table 2. Different productions presented by 1 or 2 students in each course (originality).

Different productions presented by 1 or 2 students	MEPE	MPrePri	M1,2
Number	7	10	4
Percentage (%)	29,2	47,6	22,2

The following figures (Figure 8, 9 and 10) show original productions presented in each one of the courses, that can also be considered original in the global context of the three courses, since they were presented by only one student.

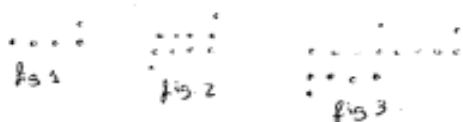

Figure 8. MEPE student.

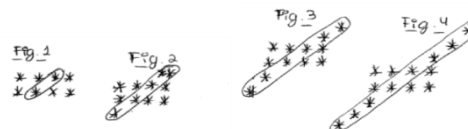

Figure 9. MPrePri student.

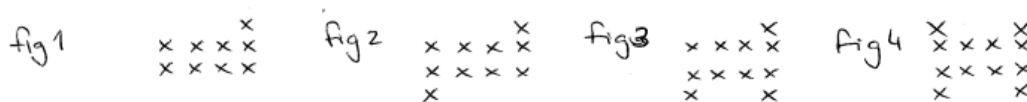

Figure 10. M1,2 student.

Students considered the variation of the number of rows and/or columns of the figure having, in some cases, associated it with the arrangement of the stars. They also considered geometric and symmetric configurations. Mostly, the students focused on the variation of the number of rows and columns to build the different terms of the sequence, even if they have presented various sequences.

However, we can highlight in each course some students who presented proposals that show a change in the way of “looking” to the figure initially given, revealing their flexibility. First, these students structured a sequence, or more, focusing on the variation of the number of rows, columns or stars at the extremes of a central configuration and then presented another sequence in which the focus is the geometric arrangement of the stars. From a figure to the following in the sequence the “centre piece” suffers geometric transformations: half-turns and/or translations.

Figure 11 shows the work of a student of MEPE (student C) who went from a sequence in which there was an increase of the number of lines plus some stars in the extremes, to a sequence of “P”s that developed with the use of half turns.



Figure 11. Sequences proposed by student C (MEPE).

Figure 12 illustrates the work of a student from MPrePri (student V) who changed from a sequence in which the stars increased from a term to the next, by changing the number of columns, to another sequence based on a more geometric look, in which the variation of a term to the next was made by fitting the pieces like a puzzle.

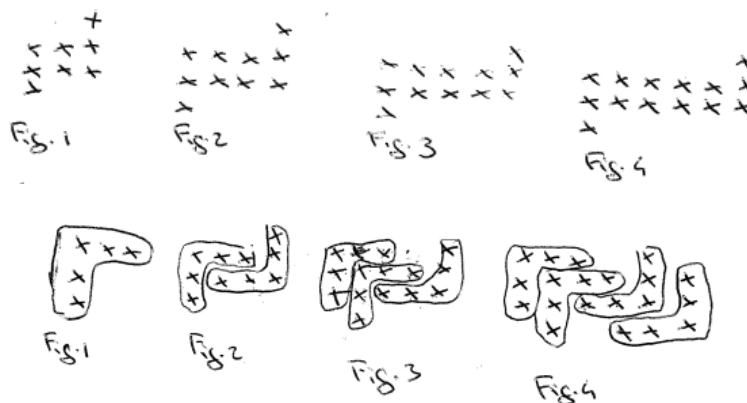

Figure 12. Sequences proposed by student V (MPrePri).

In some cases, the way students surrounded the group of stars in the first figure (minimum motif) leads us to state that the students abstracted from the number of stars in each figure and focused on the configuration of the minimum motif in each new term of the sequence, like it were a puzzle. For instance student V said “I saw two L’s, in figure 2”.

In the following productions, from a student of M1,2 (Figure 13), we can also observe a transition from a disposition where the number of stars in the extremes of the configuration varied, to another sequence that begins with a “P”, which in this case was not highlighted, as happened with the student C from MEPE, and could be developed with the use of half turns.

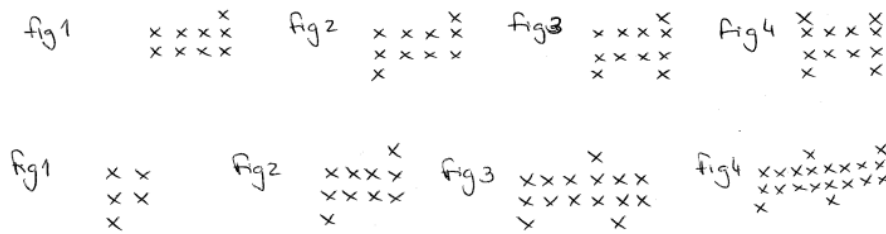

Figure 13. Sequences proposed by student A (M1,2).

Analysing the written work produced by the pre-service teachers we detected that some aspects needed to be further clarified. In this sense, we interviewed a focus group to discuss some essential issues that helped supplement that data.

The responses of future teachers to the questionnaire allowed us to say that the vast majority considers themselves to be creative, they do not understand creativity as a rare gift that only a few possess and so they believe it can be developed, taught and learned. Despite considering creativity as an individual characteristic, the majority of the students, future teachers, believes that creativity can be built collectively. From the ideas expressed by these students in the interviews, we also realized that they agreed that a student is much more creative in mathematics as more mathematical knowledge he/she has and as more positive her/his relationship with mathematics is. We confirmed that the students knew some of the dimensions of creativity, such as fluency and originality, recognizing them in their work throughout the tasks. There were references like to be creative means “solving a task in many ways” (fluency), and also “do something differently from others” (originality). They also recognized being less creative, for example, when they “always used the same representations”, i.e. the same problem structure (lack of flexibility). Flexibility was the least mentioned characteristic, in the interviews, and the least expressed in their productions.

Despite having only analysed the work of these students in two tasks, we can conclude that, in general, their productions show characteristics of creativity consistent with their responses to the questions posed in the questionnaire and their answers during the interviews.

SOME CONCLUDING REMARKS

We are seeing that creativity is emerging as a very important component that should be used in the educational process, as a way to follow the transformations in society. Creativity is a field that we are beginning to explore in the teaching and learning process in mathematics, in which educators, teachers and students must be engaged. We all recognize that the teacher plays an essential role in the process of teaching and learning. What he/she thinks, knows and does in the classroom with the students can make the difference in teaching practice, using the ideas of Varygiannes (2013), moving from “one way of doing things” to “expertise in using a variety of approaches”. The teaching and learning process must give students the opportunity to “think outside

the box” but this is only possible if teachers believe that creativity is teachable and know how to do that.

This work is a first step in the direction of addressing creativity in teacher education. Throughout the results we identified that teachers of all levels believe that they can teach students to be creative and their productions on the proposed tasks, open-problems or situations, and show that they have some characteristics of creativity. A few students demonstrated no flexibility but some rigidity of thinking having fixation on some contents and structure. We need to break their mental sets of knowledge, as referred by Haylock (1997). A possible explanation is a lack of mathematical knowledge and/or divergent thinking, or little confidence in their ability to do mathematics, as some of them mentioned. We also must help teachers in their own classes, and for that we need to construct educational materials for them to use with their own pupils, to develop mathematical creativity, in particular, design rich and challenging tasks. These are the biggest challenges to overcome in teacher education.

REFERENCES

- Aiken, L. R. (1973). Ability and creativity in mathematics. *Review of Educational Research*, 43(4), 405-432.
- Barbeau, E. & Taylor, P. (2005). Challenging mathematics in and beyond the classroom. *Discussion document of the ICMI Study 16*. <http://www.amt.edu.au/icmis16.html>
- Bolden, D., Harries, & Newton, D. (2010). Preservice primary teachers' conceptions of creativity in mathematics. *Educational Studies in Mathematics*, 73(2), 143-157.
- Burton, L. (2004). Confidence is everything: Perspectives of teachers and students on learning mathematics. *Journal of Mathematics Teacher Education*, 7, 357-381.
- Conway, K. (1999). Assessing open-ended problems. *Mathematics Teaching in the Middle School*, 4(8), 510-514.
- Graven, M. (2004). Investigating mathematics teacher learning within an in-service community of practice: The centrality of confidence. *Educational Studies in Mathematics*, 57, 177-211.
- Hannula, M. S (2011). The structure and dynamics of affect in mathematical thinking and learning. In M. Pytlak, T. Rowland & E. Swoboda, *Proceedings of the Seventh Congress of the European Society for Research in Mathematics Education*, (pp. 34-60). Rzeszow, Poland: ERME.
- Haylock, D. (1997). Recognising mathematical creativity in schoolchildren. *ZDM*, 29(3), 68-74.
- Mann, E. (2006). Creativity: The Essence of Mathematics. *Journal for the Education of the Gifted*, 30(2), 236-260.
- Pehkonen, E. (1997). The State-of-Art in Mathematical Creativity, *ZDM*, 29(3), 63-67.

- Oliveira, H., & Hannula, M. S (2008). Individual prospective mathematics teachers. In K. Krainer & T. Wood (Eds.), *The International Handbook of Mathematics Teacher Education*, Vol. 3, (pp.13-34). Rotterdam: Sense Publisher.
- Pajares, M. F. (1992). Teachers' beliefs and educational research: cleaning up a messy construct. *Review of Educational Research*, 62(3), 307-333.
- Silver, E. (1997). Fostering creativity through instruction rich in mathematical problem solving and problem posing. *ZDM*, 29(3), 75-80.
- Stein, M. K., & Smith, M. S. (1998). Mathematical tasks as a framework for reflection: From research to practice. *Mathematics Teaching in the Middle School*, 3(4), 268-275.
- Vale, I. & Pimentel, T. (2011). Mathematical challenging tasks in elementary grades, In M. Pytlak, T. Rowland & E. Swoboda, *Proceedings of the Seventh Congress of the European Society for Research in Mathematics Education*, (pp.1154-1164). Rzeszow, Poland: ERME.
- Vale, I., Pimentel, T., Cabrita, I., Barbosa, A. & Fonseca, L. (2012). Pattern problem solving tasks as a mean to foster creativity in mathematics. Tso, T. Y. (Ed), Opportunities to learn in mathematics education, *Proceedings of the 36th Conference of the International Group for the Psychology of Mathematics Education*, 4, 171-178. Taipei, Taiwan: PME.
- Varygiannes, D. (2013). The impact of open-ended task. *Teaching Children Mathematics*, 20(5), 277-280.

NOTICING CREATIVITY ISSUES WHEN FUTURE TEACHERS ANALYZING PROBLEM SOLVING DIALOGUES

Yuly Marsela Vanegas, Joaquin Giménez

Barcelona University

ymvanegas@ub.edu; quimgimenez@ub.edu

This paper explores the initial ideas of prospective preschool teachers relating to arithmetic problem solving activities, in Spanish Educational Formation Program. The results of an initial professional activity is discussed, in order to identify initial content knowledge, and noticing perspective of creativity traits observed by future teachers when they analyze for the first time some dialogues of the children solving arithmetic problems. Future teachers identify spontaneously some traditional problem solving strategies, and increase their observational perspective about what can be an interpretation of children's behaviour, when they have some theoretical and methodological tools of analysis and group discussion. Nevertheless, it's not clear if their ability of noticing is really growing.

INTRODUCTION

Reports on children's mathematical achievement pointed out that many children at preschool level successfully engaged in mathematical thought and these skills are predictors of later school mathematics achievement (Munn, 1997). The process of learning and instruction of early problem solving skills is considered a way of improving basic capacities. In such a perspective, research and expert practice indicate that certain concepts and skills are both challenging and accessible to young children (Seo & Ginsburg, 2004). It's generally assumed that to support high quality mathematics education, institutions, program developers, and policy makers should create more effective early childhood teacher preparation and continuing professional development. Consequently, it's important to improve teachers' ability to identify children's behavior, in order to support children's thinking and take the best professional decisions. But, there is a large lack of research referring to the impact of early acquirement of didactic analysis competence of future teachers being non specialists on mathematics education. In particular how future teachers interpret relevant events that are difficult to see, because of early use of mathematical language as it happen with early childhood education.

In such a framework, our main aim in this presentation is to characterize some trends of the initial process of how future teachers notice strategies and mathematical content that children developed when faced with problem solving activities (Jacobs, Lamb & Philipp, 2010). In particular, we are interested to see if it appears in their observations some creativity traits when they analyze children's strategies. The school experience presented to the future teachers is a part of an arithmetic problem solving workshop in

kindergarten, within an atmosphere of total freedom to choose manipulative and procedures of resolution, in which children invent their own strategies, discuss them within the group and decide which strategies will be the “official” one for the group (De Castro, Escorial, 2007).

THEORETICAL BACKGROUND

Previous research found that the level and the complexity of preschool children’s mathematical understanding is strongly underestimated by some teachers (Rudd et al., 2008). Unfortunately, in many cases, future teachers assume that mathematical abilities develop by itself without any support, and problem solving strategies are far away from the possibilities of the childhood (Clements, 2004). On the other hand, we know that for a mathematics teacher, a problem means an attractive question of whose steps or ways of solution students do not know but have necessary preliminary information (Schoenfeld, 1989). In this sense problem solving not only means finding the result of a mathematics question but also means facing with new conditions and finding flexible, effective and elegant solutions for these conditions. We assume a theoretical investigative approach (Ponte, 2007) to analyze teaching and learning mathematical processes in kindergarten (Baroody, 2003), in particular for problem solving activities.

Creativity, problem solving and preschool settings

It’s regularly assumed that investigative approaches enable children to experience mathematics (in particular, problem solving) within a context that is meaningful to them. To do this, it’s fundamental for teachers to grow personal subject knowledge in order to fully extend the potential learning of children in such investigative approach. In order for a teacher to act as an informed other and scaffold the children’s potential learning, they need to draw on their knowledge base about what the children know, understand and are able to learn (Clements, 2004). In this investigative framework, creativity is considered an inherent characteristic of building mathematical knowledge and it can be widely promoted in the school population in general (Silver, 1997). We interpret creativity as the group of elements that help to include mathematics within the education process as something that develops a flexible thought, that motivate the construction of problems and situations, that promotes the solution of problems in real contexts and that improves imagination, all of it in an environment where both teacher and student enjoy mathematics, and where the students feel free to make mistakes and to learn from them. In this sense, for us to mathematically train teachers in a creative way, means to foster the ability to solve problems that allow the development of structures, recognizing their generation, decide identifying and communicating sagaciously the learners’ acquisition conflicts, in order to encourage future teachers in both mathematics production and difficulty confrontation (Sequera & Gimenez, 2005). In such approach, it’s important to start with a worthwhile task, one that is interesting, and creates a real need to learn or practice. Experiencing mathematics in context is not only more interesting to children but more meaningful (Baroody 2000, p. 64).

At any given point in their development children will use 5 or 6 different strategies. Higher and lower order strategies coexist and compete. Thus, development is not the process of moving from one strategy to the next (Baroody, 2000) but to build and several appropriated strategies in order to show a good interpretation of the problem needed for having a result. In this paper we also assume that mathematical thinking is not primarily about developing isolated arithmetic skills but about posing and solving problems, which require the ability in quantitative and relational concluding (Oers, 2004).

Teachers' construction of noticing skills.

The process of noticing is an important issue in teacher development and in particular, as a first point for doing an in-depth didactical analysis. We assume that noticing relates two important professional skills (Jacobs et al., 2010): (a) the extent to which future teachers attend to the mathematical details in children's strategies and (b) the extent to which the teachers' reasoning is consistent with both the details of the specific children's strategies and the research on students' mathematical development.

We assume that for detecting traits of creativity, it's fundamental to identify evidences of noticing about: (a) children's problem solving strategies developed in different school dialogues, and (b) deep observations and interpretation about arithmetic knowledge built by individuals, and processes identified. The discourse analysis generated by pre-service teachers enables them to show what they consider relevant, and group discussion offers the possibility of proposing other formulations to others, raising objections and so on (Fernandez, Llinares & Valls, 2013). We consider that preschool future teachers have previous personal knowledge about what children and teacher are doing, but they need theoretical materials to improve their analysis (Fernandez, Llinares & Valls, 2013). For instance, future teachers should know elements about semantic analysis coming from problem solving research. To identify creativity is related to the consideration of unusual strategies, and to show if children establish relations and structures, even not explicitly. In our study we want to see how preschool future teachers recognize how children are creative thinkers going beyond algorithms (Leikin, 2009) by identifying what is behind the children's statements and their arguments. To categorize future teachers' comments, we assume the following indicators of creativity: originality, flexibility, fluidity and elaboration (Sequera & Giménez, 2005). Originality or novelty is the first to appear, unusual answering, means the ability to promote no immediate relations and far connectivity among problem solving strategies (Callejo, 2003). Flexibility means considering different ways of knowledge, by using different representations, even methodologies, and ability to interrelate interpretations, and openness in problem solving (Callejo, 2003). Fluidity is related to generation of ideas, communication and ability for judgement in challenging situations (Callejo, 2003). Elaboration is understood as the ability to face complex situations as an integrated configuration of meanings (Reigeluth & Stein, 1983).

For our purposes, we considered just three components of creativity as it is in the research of Amaral & Carreira (2011) which analyze problem solving strategies with Primary students. In fact, it's difficult to find elaboration and complexity in Kindergarten.

RESEARCH METHODOLOGY

A total of 30 third-year pre-service teachers studying in the Early Childhood Education Program (so called, Grau d'Educació Infantil) at Barcelona University participated to a professional initial activity about numbers and problem solving, in which we propose to recognize and to interpret some classroom situations, by analyzing problem solving strategies and mathematical content behind the activity. In the analysis of pre-service teachers' answers of these two tasks, we focus on two professional aims relating noticing: (a) how pre-service teachers integrated mathematical elements in the written text produced relating the characteristics of the problem and the strategies. And also (b) to improve collaborative discussions during didactical analysis.

A specific learning professional environment for future teachers was designed to get our instructional goal as a base for noticing. This learning environment requires that pre-service teachers first think about the issue; interact among them in order to discuss about aspects of the teaching of problem solving strategies and numbers' operations at preschool stage; reflect about theoretical issues; analyze new proposals. Our report refers upon the first two steps, because of short space, as a first didactical analysis introducing noticing reflective process. Moodle-platform provided by the University gives the opportunity to collect all the future teachers' reflections.

First professional task

It's explained the context of the problem solving school experience (De Castro et al., 2007). Pre-service teachers had to answer individually a questionnaire in which they did a first analysis of six dialogues within the experience. In this task, pre-service teachers had to respond to the next questions: Look at the dialogues, and tell us which processes you can see in each of the dialogues. (1) Which strategies and mathematical content have been developed during each dialogue? (2) What aspect of de dialogue favors the solving process, specially observing the role of the teacher and students? The answers were after discussed among small groups. Natural strategies about adding, missing values, multiplication, and sharing processes, have been expected to be observed.

We will describe below two of the dialogues as an example, explaining some expectations about their observations, during first professional task.

First dialogue asks for facing an addition problem. "In the school farm, there are 4 male ducks and five female. How many ducks in total?" Three different answers appear: ten, nine and seven. Who said ten, corrects him, telling "I hear five and five". Albert argues that he used a table of numbers 1 to 100. It was explained to future teachers that children didn't discuss about addition and its symbolic use before the classroom experience, but

they can solve problems by using materials. Therefore, reflecting on this kind of dialogue, we hope that the future teachers not only recognize the addition but realize that children should transform the data into a different representative form such as the use of a manipulative material. It's important to notice that the use of manipulative is a consequence of a "way of doing" not directly promoted by the problem statement. The trainer also introduces questions to reflect about the conceptual scaffolding. In this case, we ask future teachers: "what do you think Albert did?" And also: "what do you think some people telling seven?" With these questions we want to see if future teachers recognize mathematical knowledge behind students' answers, as an important part of noticing.

In a second dialogue we see that the use of manipulative aids, gives opportunities for self controlling. It's the case of Sandra in which she designed two arrows for representing the process. In third dialogue the problem evokes a subtraction situation, in which it's impossible to have more if you have lost, fourth and fifth dialogue asks the children to see groups as a beginning of multiplication and division.

Final dialogue, tells about having 8 ducks on the farm and one day came a few more. Since then there are 14 ducks on the farm. How many ducks came over? Christine: says "Was in fourteen [I point the finger]. No, sorry. I was in eight [points to eight accounts from there to 14] and done: one, two, three, four, five, six. And so is fourteen. Mary explains that ducks were ... (use two cubes together) and... those who came flying are these (showing 1cube). And I counted six. Peter uses blocks and he did a mistake, because he counted to nine".

Second professional task

First step of the second task was to argue some personal answers. After personal initial writings, it's proposed to discuss in group of four in order to give a common answer about one of the dialogues, but doing a reflection about the use of individual processes, representations, and personal meanings in each dialogue. In a second part, we provided a set of theoretical categories about problem solving: (a) classical notions of heuristics according Polya, (b) counting strategies (Baroody, 2000); (c) semantic classical classification of verbal problems of addition and subtraction (Carpenter, et al. 1988) and (d) categories about the use of concrete materials, diagrams or digits as numerical representations. The main aim for this professional task is to reveal the role of processing data identified by each child, to improve an individual perspective of noticing analysis. Each group should analyze one of the dialogues, by using the categories introduced. The common ideas have been discussed by all the students as a communicative group debate. A third professional task, not included in our paper, confronts future teachers with the teacher-researcher comments.

During research analysis, a team of three researchers tries to have a consensus, if the future teachers have been observed traits of creativity above explained. We codify the answers according three categories: (a) Future teachers *consider originality* when they children interpret images or diagrams or/and uses unusual and inventive strategies or

uses trial and guess in an organized way during the problem solving process. (b) We say that a comment *finding flexibility* if future teachers talk about children using appropriate mathematical representations or using different effective representation systems, or/and use connections between representations and interrelates givens and goals in order to give a solution. (c) It's called that future teachers *identify fluency*, when future teachers interpret the children reveals the strategy used in the problem solving process and communicates in an organized way the problem solving process. We also consider that future teachers identify fluency when using a specific mathematical content knowledge to describe the children's behavior having a direct influence over the solution. We assume that it's difficult to say in this category that preschool children develops and explores mathematical concepts and procedures.

We collected all the prospective teachers writings (posted to the Moodle platform), some group discussion and whole class discussion were audio taped and constituted data for our research process. Finally, a team of researchers found commonalities in the conjectured approaches, as results of noticing process always based upon future teacher texts.

RESULTS AND DISCUSSION

First of all, we explain how the future teachers (called from now St-#) identify heuristic strategies used by the children and understand content arithmetic knowledge recognized in the dialogues. After that, creativity traits are discussed.

The main heuristics observed by the future teachers are the use of diagrams and guessing/proving. We see in their arguments the reference to a global observation or action. For instance it's said "children go testing and finding out the solution to obtain the definitive answer" (St-9) or "I was surprised by the strategy of using cubes"(St-4). Only two of future teachers talk about analysis/ synthesis strategy before group discussion. In many cases future teachers confuse strategies with content knowledge observed. This situation is evident in sentences like "In the dialogue... we see the children subtracting" (St-1). It surprises that almost all the future teachers talk about Sandra as cognitively different from the other children, doing hypothesis and conjectures. She is also identified as one who gives arguments relating different representations "She used cubes to do graphically the addition, because the digits of two hands are not enough in order to achieve the result" (St-12).

In some addition problems, future teachers talk about adding as putting together by using designs or material, because it's explicit in the dialogue. As it was expected, the future teachers don't say anything about guessing as different to retrieval in which the child explains that he or she guessed. The child makes no attempt to retrieve an answer from memory, but simply provides sometimes any number that comes to mind, which implies that the number is randomly generated. There is evidence, however, that children spontaneously activate the sum of the two numbers, so it seems likely that guessing somehow involves consciously not attempting retrieve an answer.

About counting strategies

Many future teachers also recognize that in some dialogues addition strategy involve counting each of the addends separately, then counting up to the first addend and continuing to count on by the number indicated by the second addend (St-24). Others explain that “we can find the composition and decomposition strategy” (St-18). They also identify the count from first strategy involving “counting on from the first addend by the number indicated by the second addend” (St-22, St-19). They also identify that finger recognition involves “putting up fingers to represent each of the addends” (St-20, St-26), and assuming that the child recognises the total, which is different to using fingers to assist counting “(St-17). Any of the future teachers interpreted as counting on from the larger of the two addends by the number indicated by the smaller of the addends.

When subtraction is evidenced, it’s considered the observation of counting down using cardinal principle by observing the use of material (St-23). But other future teacher said: “In the case of Diego, he uses multilink pieces to find the answer, putting 14 as a pile, and take off five, before counting” (St-21). Let’s say that the future teachers talk about counting as common sense strategy, because they never received any specific training about such counting strategies. It’s interesting to say that one student uses a table to show the strategies found in a systematic way (St-10).

Creativity in children’s strategies and arithmetic understanding

To analyze creativity, we codified the future teacher’s writings according originality, in terms of what future teachers understand as original and innovative strategies, flexibility and fluency.

We found that it’s not easy to identify if several children’s actions and statements reveal some specific new or unusual mathematical strategy. Five future teachers identify that children use counting-on from first, and counting-on from large only in one dialogue. In many explanations, it appears the expression “surprising” more than “unusual”. When subtraction is evidenced, the observation of deleting from the highest number is considered unusual (St-2, St-21). Some future teachers talk about 1-100 table as new and surprising for them. But only a few of them talk about its relation with arithmetic counting strategies “Such a strategy is intermediate between counting all, and count from first” (St-5). “...A child instead of counting as the others, he uses colours” (St-20).

We see nine people doing several comments about flexible understanding and strategies relating representations. Let’s say some examples. In some cases there are general comments about “the use of materials for abstracting processes” (St-18). In other cases, relates connections with building structures: “I was surprised...the child organized groups of two eggs without representing the amount of hen” (St-9); or uses a way for representing equal amount (St-19, St-20). In other cases, connecting “...

materials gives opportunities to find solutions by themselves” (St-16). It’s difficult to find fluency because it’s not easy to explain mathematical relations.

It’s not regularly understood using fingers as relating representations. Therefore, it’s difficult for them to identify it as good or fluid strategy. Just some future teachers tell us “I was surprised with Cristina’s talk because the use of fingers on one hand, but as we need four digits, we remove one digit to have four plus” (St-24).

In many comments analyzed, we observe that it’s difficult for future teachers to identify some of the strategies as unexpected or interesting by itself. They tell us as useful strategies, but they consider as unexpected what it’s different from their own strategy to solve. They used sentences as: “I cannot understand... because it’s more easy to do...in such a way” (St-15). When they discuss in a group to make a common opinion, they mainly observed self-control of results in many of the children analyzed.

About teaching role in promoting challenge and creativity

Future teachers assume (not always explicitly) a set of teaching strategies contributing to improve the dialogue as a way of building collective knowledge: (a) The teacher *did not pressure children to choose a particular solution*, even if children refused a number of possible solutions offered by the other child; (b) she quietly observe from a short distance to be able to intervene if necessary, but using words that *didn’t judge* either side of the disagreement; (c) “Beatriz (the school teacher), *accepted the children’s solutions* if both parties were satisfied, even if the solution did not make sense to the adults” (St-26). (d) *define accurately the situation*, which in itself, sometimes moved children toward solving the problem; (e) she almost always promote asking questions, and *asking for clarification* as good strategies to involve children into participation.

Any of the students interpret by themselves the importance of helping children intuitions of properties, giving them the vocabulary to describe the properties. It only appears during the whole group discussion after small group discussion.

About second task observations

During the future teachers’ group discussion, they continue to assume some misunderstandings as misinterpretations of the problem statements. Some disagreements appear, because of the different interpretations of problem solving strategies. After being introduced with theoretical categories and explanations, we see that not every indicators used to analyze the problem solving activity were fully understood. For instance the future teachers associated an unexpected multiple grouping to a subtraction problem. They found in dialogues 5 and 6 the situations in which strategies are more explicit than others, probably because in such problems there are different ways of solving. For 66,6% of the future teachers, the use of manipulatives or digits is crucial for solving the problems, but just 36,6% tell us about them as alternative or unexpected strategies.

When using theoretical indicators about representations, 90% of future teachers found the use of number line as the main tool for solving the most difficult problems. When analyzing children’s behavior with the lens of theoretical tools provided during second task, every future teacher knows that *adding to and taking away* means knowing that adding to a collection makes it larger and subtracting makes it smaller. But, some future teachers accept that children use such idea as common sense strategy combined with counting and (de)composing, children can solve simple problems with increasing efficiency.

About evolution in traits of creativity

To see how is the evolution of future teachers; we use the same categories of identifying creativity above explained to see their comments on the second task after discussing about theoretical tools. In the table 1, we see the different percentage of future teachers that we find in each category.

Table1. Percentage of student teachers identifying the categories of creativity.

N= 30	Assuming Originality	Finding Flexibility	Identifying Fluency
First approach	36,6%	30%	16,6%
After group discussion	53,3%	66,6%	40%

After group discussions, more students talk about some traits of creativity. The main aspect relates the role of counting strategies, and the stability of the use of processes needed to solve the problems. One of the interesting changes in group discussions is that in both moments, it appears the idea of cause-effect as a principle necessary to interpret an equality problem. There is also a general observation that in kindergarten, children sometimes solve simple multiplication (grouping) and division (partitioning) problems by direct modeling with objects.

It’s not so easy that future teachers talk about the need for negotiation according previous pedagogical reflections. St-4 (24 years old future teacher) said: “It was becoming clear that children were learning the process of finding solutions on their own. In some case I see children negotiating the operational meaning...” Some future teachers interpret that in such a way of doing in the classroom, the teacher uses the dialogue to help children feeling empowered to express their needs.

CONCLUSION

This study contributes to the research base on how pre-service teachers make sense of preschool mathematics thinking in a specific learning environment with the hypothesis that interaction focus on a specific goal can help pre-service teachers to develop the noticing skill. Future teachers identify spontaneously some traditional problem solving strategies, and increase their observational perspective about what can be an

interpretation of children's behavior, when they have some theoretical and methodological tools of analysis and group discussion.

Nevertheless, it's not clear if their ability of noticing is really growing. They see more aspects, but they assume interpretations not directly associated to evidences found in the dialogues. Future teachers accept theoretically, that throughout the early years of life, children notice and explore mathematical dimensions of their world. But, it seems initially difficult for them to evoke rich mathematical ideas appearing in the dialogues without any specific preparation about analyzing children's texts.

We suspect that prospective teachers are more fixed on the school teacher intervention than recognizing mathematics behind child's comments. They look at the problem solving process as global set of actions giving a nice end. Let's say that as an initial study, we don't explain here neither the growing of future preschool teachers when improving their didactical analysis nor the role given of dialogue in developing problem solving capacities.

The study reveals the difficulties of future teachers to notice authentic traits of creativity in problem solving activities, because of methodological difficulties on overcoming their own perspectives about evidences. Problem solving has been interpreted, by future teachers, as an important element in classroom life, enriching the children's experiences and language and learning. Problem solving activity is not easy. It is one of the hardest skills to build. It takes a lot of self-control for the teachers *and* the children (Gross, 2005).

ACKNOWLEDGMENT

We would like to show gratitude to the funding from the project I+D+I EDU2012-32644 of the Ministry of Science and Innovation of Spain, by using some part of the theoretical framework introduced for Secondary School Training.

REFERENCES

- Amaral, N., & Carreira, S. (2012). An essay on students' creativity in problem solving beyond school: Proposing a framework of analysis. *Proceedings of ICMI 12th International Congress of Math Education*. (pp. 1419- 1428). COEX. Seoul. Corea.
- Baroody, A. (2000). Does mathematics instruction for 3 to 5-year olds really makes sense? *Young Children*, v. 55, 4, 61-67.
- Baroody, A.J. (2003). The development of adaptive expertise and flexibility: The integration of conceptual and procedural knowledge. In A.J.Baroody & A. Dowker (Eds.), *The development of arithmetic concepts and skills* (pp. 1-33). Mahwah, NJ: Lawrence Erlbaum Associates.
- Callejo, M.L. (2003) Creatividad matemática y resolución de problemas. *SIGMA* 22, 25-34.

- Carpenter, T., Fennema, E., Peterson, P., & Carey, D. (1988) Teacher's pedagogical content knowledge of students' problem solving in elementary arithmetic. *Journal for Research in Mathematics Education*, 19, 5, 385-401.
- Clements, D. (2004). Major themes and recommendations. In D. H. Clements, J. Sarama, & A. DiBiase (Eds.), *Engaging young children in mathematics: Standards for early childhood mathematics education* (pp. 7-72). New Jersey: Lawrence Erlbaum.
- De Castro, C., & Escorial, B. (2007). Resolución de problemas aritméticos verbales en la Educación Infantil: Una experiencia de enfoque investigativo. *Indivisa, Boletín de Estudios e Investigación*, Monografía IX, 23-47.
- Epstein, A.S. (2007). *The Intentional Teacher: Choosing the Best Strategies for Young Children's Learning*, Washington, DC: NAEYC.
- Fernandez, C, Llinares, S., & Valls, J. (2013). Primary teachers professional noticing of students' mathematical thinking. *The mathematics Enthusiast Special Issue: International perspectives on problem solving, research in Mathematics Education*, v.10, n.1&2 (Information Age Publishing), 441-468
- Gross, C. (2005). *Promoting Problem Solving with Young Children: An Approach to Community Building and Classroom Management in One Classroom*. (Unpublished PhD thesis), Columbia University.
- Jacobs, V., Lamb, L., & Philipp, R. (2010). Professional noticing of children's mathematical thinking. *Journal for Research in Mathematics Education*, 41(2), 169-202.
- Leikin, R. (2009). Exploring mathematical creativity using multiple solution tasks. In R. Leikin, A. Berman, & B. Koichu (Eds.), *Creativity in Mathematics and the Education of Gifted Students* (pp. 130-144). Rotterdam: Sense Publishers.
- Munn, P. (1997). Children's beliefs about counting. In I. Thompson (Ed.), *Teaching and learning early number*, (pp. 9–20). Philadelphia: Open University Press.
- van Oers, B. (2004). Mathematisches Denken von Vorschulkindern. In W. E. Fthenakis (Ed.). *Frühpädagogik International: Bildungsqualität im Blickpunkt*. (pp. 313-329). Wiesbaden.
- Ponte, J.P. da (2007). Investigations and explorations in the mathematics classroom *ZDM*, 39 (5-6), 419- 430.
- Reigeluth, Ch., Stein, F. (1983). The collaboration theory of instruction. In C. Reigeluth (Ed). *Instructional design; Theories and models. An overreview of their current status*, pp. 335-381. Hillsdale, N.: L. Erlbaum Ass.
- Rudd, L. C., Lambert, M. C., Satterwhite, M. & Zaier, A. (2008). Mathematical Language in Early Childhood Settings: What Really Counts? *Early Childhood Education Journal*, 36, 75-80.

- Sequera, E., Giménez, J., & Servat, J. (2005) Detecting traits of creativity potential in mathematical tasks in prospective primary teachers. *Proceedings ICMI-EARCOME 3. China*. Shangai.
- Schoenfeld, A. (1989) Reflections on problem solving theory and practice. *TME*, 10, n°1&2, 9-33.
- Sherin, M., Jacobs, V., & Philipp, R. (eds.) (2011). *Mathematics Teacher Noticing. Seeing through Teachers' Eyes*. New York: Routledge.
- Silver, E. A. (1997). Fostering Creativity through Instruction Rich in Mathematical Problem Solving and Problem Posing. *ZDM – International Journal on Mathematics Education*, 29(3), 75-80.
- Seo, K.-H., & H.P. Ginsburg (2004). What is developmentally appropriate in early childhood mathematics education? In *Engaging young children in mathematics: Standards for early childhood mathematics education*, eds. D.H. Clements, J. Sarama, & A.-M. DiBiase, 91–104. Mahwah, NJ: Lawrence Erlbaum
- Sequera, E., & Giménez, J. (2005). Detecting traits of creativity potential in mathematics tasks with prospective Primary Mathematics Teachers. In H. Meissner (Ed.) *EARCOME 3*. Shangai. East China Normal University. CD.
- Van Es, E., & Sherin, M. (2002). Learning to notice: Scaffolding new teachers' interpretations of classroom interactions. *Journal of Technology and Teacher Education*, 10, 571-596.

PRACTICE IN THE MATHEMATICAL MODELLING ENVIRONMENT

Bárbara Cândido Braz, Lilian Akemi Kato

State University of Maringá, Brazil

babicbraz@gmail.com, lilianakemikato@gmail.com

This article presents a study about the formation process of Local Communities of Practice (LCoP) into the school environment during the development of a Mathematical Modelling activity, viewed by the Mathematics Education perspective. From the elements that characterize the formation of LCoP in Mathematics class, presented by Winbourne and Watson (1998), we analyzed the practices shared by four students during the interactions occurred in the development of a Modelling activity. The study had as its background a third grade class of a Teacher's Education Course, at the intermediate level, of a public school in the Paraná State, Brazil. The work shows how the Mathematical Modelling favors significant discussions that assign legitimacy to diverse voices in classroom, making not only the teacher, but also students be recognized as mathematically competent, promoting the learning of mathematics.

INTRODUCTION

In this work, we took the Theory of Situated Learning (Lave & Wenger, 1991; Wenger, 1998), as a perspective of social learning that focuses on the individual and suggests that knowledge is constructed from a series of interactions between people and the world (Boaler, 2001). According to Boaler (2001), it is important to engage students in situations embracing the application of knowledge, not only in order to gain a more detailed knowledge, but also in order to involve students in practices required in other contexts.

In this regard, the same author emphasizes the use of Mathematical Modelling¹ as an alternative that may favour a less compartmentalized learning of mathematics, highlighting the richness of discussions and the mathematical procedures that emerge in the classroom, providing students with opportunities of involvement in mathematical practice, outside the school context.

According to Boaler (2001, p. 121), the Theory of Situated Learning has offered a new perspective for the development and the use of knowledge, laying special emphasis on the use of Mathematical Modelling.

To Lave and Wenger (1991), learning is developed in certain environments called Communities of Practice (CoP). In the school environment, these communities have specific characteristics, since the particularities of the classroom are taken into account, creating a delimited environment. Winbourne and Watson (1998, 2008) designate a

Local Communities of Practice (LCoP) the communities incorporated in the course of mathematics lessons, and show elements that must be characterized to a LCoP be identified in Mathematics class.

Considering the elements that characterize the formation of LCoP, presented by Winbourne and Watson (1998), David Watson (2008) and Winbourne (2008), along with the theory of Situated Learning (Lave & Wenger, 1991; Wenger, 1998), this paper aims to make notes about the contributions of Mathematical Modelling, by the Mathematical Education perspective, in the process of formation of LCoP.

According to Frade (2003), the opportunities that are given to students in their school practices, aiming to promote the exchange of experiences, have a great impact in the engagement of students involved in a practice². Our hypothesis is that the Mathematical Modelling environment promotes the student-teacher, student-student and student-activity interactions in order to contribute to the formation of LCoP. In the course of the text, it will be presented analyses of negotiations held by a group of four students, during the development of a Modelling activity, to exemplify such contributions.

THE ADOPTED PERSPECTIVE OF THE MATHEMATICAL MODELLING

In Mathematics Education, researchers use some conceptions of Modelling as a teaching method, a teaching and learning alternative, or a pedagogical strategy. Each of these denominations represents different perspectives of Modelling, and reveals a conception of teaching and learning of mathematics involving different implications regarding the pedagogical practices of Mathematics.

Among the Modelling concepts presented by the literature, we adopted the one defined by Barbosa (2007, p. 161) as “learning environment in which the students are invited to investigate, through mathematics, problems from other disciplines or daily situations”. Unlike other conceptions, this author do not suggests prefixed procedures to the Modelling process. It is an environment based on questioning and investigating processes, it means that students do not have schemes defined a priori to understand the problem-situation that has "a domain outside the mathematics discipline" (Barbosa, 2001).

The environment mentioned by Barbosa is understood by Skovsmose (2000) as the conditions which the student is involved to develop certain activities. Such environment is proposed in the form of an “invitation”, being incumbent to students accept it, get involved, or not, to the learning environment organized by the teacher (Barbosa, 2001, p. 6). According to the author, the involvement of students occurs as their interests lie with the invitation.

In order to analyze the processes used by the students in the Modelling environment, Barbosa (2007) focuses on the discursive activity. According to the author, when students develop a Modelling problem, many kinds of discussions may arise among them, as: mathematical, technical, reflective and parallel discussions.

Barbosa (2009) explains that the mathematical discussion “refers to the ideas belonging to the pure mathematics field”. The technical discussion “refers to the techniques of building the mathematical model” and the reflective discussion “refers to the nature of the mathematical model, the criteria used in”. Besides, according to the author, another type of discussion, which is not related to building the mathematical model of situation, can arise in this environment: the parallel discussion, which can refer to reflections about life in society.

The fact that the problem-situation is based on a theme unrelated to the Mathematics discipline can make students, that are usually not recognized as mathematically competent in Mathematics lesson, be recognized, in this environment, by their knowledge on the subject, involving other dimensions of it.

Zawojewski, Lesh, and English (2003), for example, observed that during the development of Mathematical Modelling activities, students who are usually not considered leaders in Mathematics class, emerged as such ones at various times in the course of the activities carried out in groups.

In addition to the teacher’s voice, historically legitimated in classroom (Barbosa, 2007), other voices can be legitimated as well and have equal relevance to the development of the Modelling activity. About the discussion on the legitimacy of voices, in the process of learning, Lave and Wenger (1991) highlight the relevance of these processes stating that they are more important than the master and apprentice’s relationship, in the intentional teaching. Lave (1988) and Lave and Wenger (1991) studies show that people learn more by the relationship with other apprentices (Frade, 2003, p. 62).

LOCAL COMMUNITY OF PRACTICE

In the situated perspective, learning is known as an experience of participation in a Community of Practice (Matos, 2003). The concept of CoP, used initially by Lave and Wenger (1991), is better understood by its characterizing elements³, and not by its definition. However, the authors point out that a CoP “does imply participation in an activity system about which participants share understandings concerning what they are doing and what that means in their lives and for their communities” (Lave & Wenger, 1991, p. 98). In this sense, learning is an extension of social practice, in which participants of a community learn from each other.

Regardless of the environment where the CoP is constituted (nondrinking alcoholics, naval quartermasters, tailors, etc), it will always be supported by three crucial elements: an expertise *domain*, a *community* of people who care about the domain and a *practice* that keeps the members together. Furthermore, three elements constitute the source of the practice consistency concerning the community: the mutual engagement – the involvement of members around the goals; the shared repertoire – the routines, ways of doing things, artifacts created by the community; and the joint enterprise – the negotiation and mutual responsibility in the community.

The concept of CoP is developed by Lave and Wenger (1991) based on experiments analyzed in non-school environments. However, the authors claim to be useful to think the school learning under the same perspective. Boaler (2001), Brown, Collins and Duguid (1989), Winbourne (2008), Winbourne and Watson (1998, 2008), David and Watson (2008), Matos (2003) are some researchers dealing with school practices, that may be considered a CoP, and/or implications of situated learning in the school context.

According to Winbourne and Watson (1998), it is possible to think about Laves' ideas, in the school environment, as being LCoP, because "such communities may be local in terms of time as well as space: they are local in terms of people's lives; in terms of the normal practices of the school and classrooms; in terms of the practice [...]" (p. 94-95).

The authors explain that even with restrictions of time and space, it is possible to create, in classroom, learning situations that contribute to the formation of LCoP.

In order to identify LCoP, Winbourne and Watson (1998) point six characteristics that must be analyzed in classroom:

1. Pupils see themselves as functioning mathematically and, for these pupils, it makes sense for them to see their "being mathematical" as an essential part of who they are within the lesson;
2. Through the activities and roles assumed there is public recognition of developing competence within the lesson;
3. Learners see themselves as working purposefully together towards the achievement a common understanding;
4. There are shared ways of behaving, language, habits, values, and tool-use;
5. The lesson is essentially constituted by the active participation of the students and teacher;
6. Learners and teachers could, for a while, see themselves as engaged in the same activity.

(Winbourne; Watson, 1998, p. 103)

From the features above, and based on some ideas of the learning perspective of Lave and Wenger (1991), Wenger (1998), and Winbourne and Watson (2008), we propose an interpretative analysis of how practices, shared by students at school, can be characterized by articulating these practices to each of the topics previously mentioned. Thereunto, we alluded to an episode in classroom, in the development of a Mathematical Modelling activity.

METHODOLOGICAL APPROACH AND DISCUSSIONS

This article represents part of a survey, in development, whose goal is to investigate how the characteristics of Modelling, in Mathematics Education, contribute to the process of formation of LCoP.

In total, three Modelling activities have been developed with fourteen students from the Teacher's Education Course, at an intermediate level. In this paper, we analyze the

second activity - based on the theme “development of babies” that was chosen by the students - developed by a group of four students: Antonio, Matias, Rogério e Rosana⁴.

The Modelling problem proposed to the groups was: “Considering the following table, how can we analyze the development of a baby over the first two years of life?”. Each group had a table with data concerning the increase in weight and stature of male and female babies, throughout the first year of life. Table 1 shows the first table data available to students:

Table 1. Normal weight range and stature, by age and sex. (Adapted from <http://filhosecia.com.br/2010/08/tabela-de-peso-e-altura/>)

Sex	MALE		FEMALE	
AGE (months)	Reference measurement		Reference measurement	
	Weight (kg)	Stature (cm)	Weight (kg)	Stature (cm)
3	5.7	61	5.5	59
⋮	⋮	⋮	⋮	⋮
10	9,3	71	9,0	70
11	9,6	73	9,4	72
12	10	75	9,8	73

The strategy defined by the group initially consisted of studying the development of children. Based on the data provided, the group, after the graphical representation of the weight (p) according to age (i) (Picture 1), decided to represent the situation by an affine function. The students chose two points in the table and, by means of a system of equations, they described a function that represents the situation. Considering the affine function, they calculate the weights of a baby aged between 0 and 20 months and graphically represented the data, concluding that, on average, the increase in weight of a boy over the first two years of life, is about 400 grams. In this process, the group of students discussed mathematical, social and technical aspects, concerning the theme of the activity proposed, for about five hours.

THE FORMATION OF LCoP IN THE DEVELOPMENT OF A MATHEMATICAL MODELLING ACTIVITY: AN EXEMPLARY EPISODE

In this section, we interpret how each of the six characteristics pointed by Winbourne and Watson (1998) can be analyzed by the school practices of students, in the development of the Modelling activity, in Mathematics class.

1) Pupils see themselves as functioning mathematically and, for these pupils, it makes sense for them to see their “being mathematical” as an essential part of who they are within the lesson;

The feature 1 refers to the ways students see themselves in a LCoP. Each LCoP participant must recognize each other as mathematically competent.

To Wenger (1998), when we are in a community where we are considered full members, depending on the roles to which we are provided, we can develop ourselves more competent or less competent. The first feature must be analyzed in relation to the form of students' participation in class concerning the teacher: how students act in relation to the proposed mathematical activity?

The development of Modelling activities requires, from students involved, a different stance from that taken in the so-called traditional lessons. The teacher's attitude, in this environment, directs students to see themselves as responsible for the conduct of the activity. This can be seen through the students' statements about the development of this activity: *"I thought my participation had contributed greatly, (...) to my group"* (Matias); *"It was really nice (my participation) (...) We talked a lot. Those bunch of letters that I didn't know what for [...] I used them, but it was different, it had reliable basis"* (Antony).

2) Through the activities and roles assumed there is public recognition of developing competence within the lesson;

The second feature concerns the ways of recognition by members of LCoP. In this case, we analyze the participation and recognition of each student that formed the analyzed Group.

According to Wenger (1998), participation refers to the process of taking part in the Group, not to mention the establishment of relations with the other members. Beyond that, the author considers that an essential characteristic of participation is the mutual recognition by the community.

Throughout the negotiations held by the students, each of the participants positioned aiming to ensure more or less recognition by others, which legitimized them by their participation.

Matias, Rosana and Antonio promoted significant discussions to the development of the activity. On the other hand, Rogério didn't actively participated in these discussions, however, he proved to be engaged to the activity by following the lead of the group.

Some statements are evidence of the different forms of public recognition among students in the activity: *"I couldn't understand, Matias helped me [...] Matias distinguished himself from others, I guess, because everything we tell him, he easily gets. I think we ((the Group)) connected."* (Rosana); *"Antônio distinguished himself, because even with his difficulties, he sought to understand [...] Rosanna participated well, but Rogério was kind of outside the group, because he barely discussed."* (Matias).

3) Learners see themselves as working purposefully together towards the achievement a common understanding;

This feature is analyzed in order to determine whether there is or not an expertise domain to support the actions of students involved, leading them to the same purpose.

In these classes, we acknowledged that the Mathematical Modelling activity, developed in the perspective of Mathematics Education, created a knowledge base that stimulated students to participate in class and give meaning to their actions.

The set of tasks that constituted the domain was determined along with the development of the activity, considering the hypotheses raised: “Thus, it is observed the weight she was born with, 3.4 ((kg)); the next month she is 4.2 ((kg)). During this time, what was the development? How much does she put on weight? (...) Now that I have the points and the form of the equation, I just have to find the values of the coefficients to write down the function...” (Matias).

4) There are shared ways of behaving, language, habits, values, and tool-use;

The repertoire sketched out by the community refers to enterprises articulated and accepted by its members.

To understand 4, we used the concept of “shared repertoire” referred by Wenger (1998). According to Wenger (1998, p. 83) “the repertoire of a CoP includes routines, words, tools, ways of doing things, stories, gestures, symbols, genres, actions, or concepts that the community has produced or adopted in the course of its existence, and which have become part of its practice.”

From the first moment, Rogério, Matias, Rosana and Antonio shared a way to organize the tasks, so everyone could participate in the discussions. Each one reviewed the situation individually, and then discussed in group until they reached on a consensus, that was registered later.

The shared repertoire also includes everything that is produced and reified by the community. Therefore, the written records produced by students are also part of the repertoire that is shared by them. The written records resulted from the group enterprises that also represent the shared behaviors by the group, is showed below:

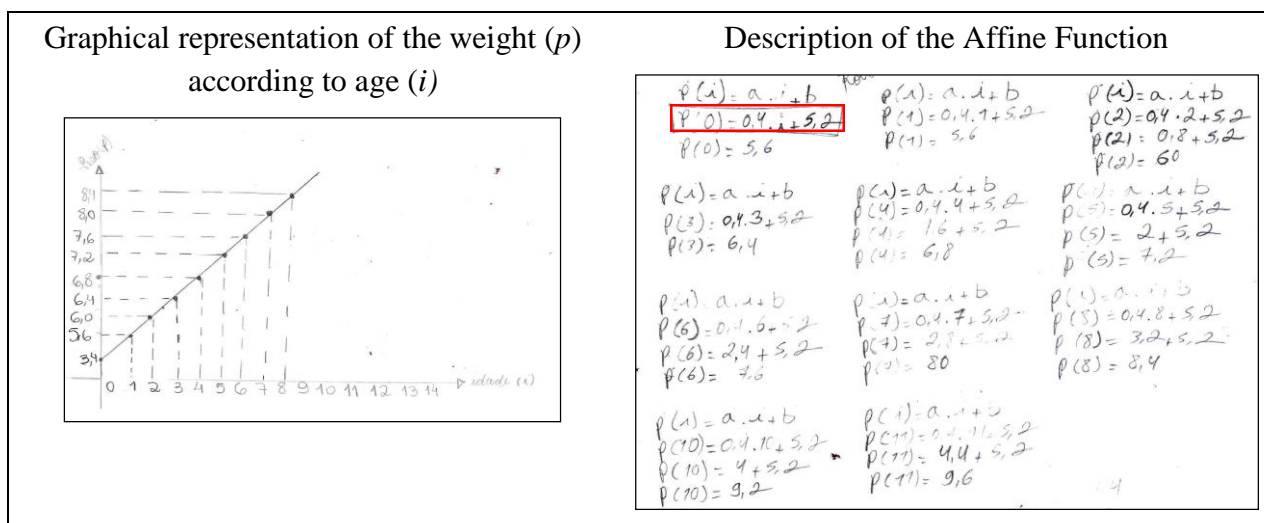

Figure 1. Processes covered by the group in the investigation of the proposed activity.

The red framework, in Picture 1, highlights the affine function representing the development of a male baby concerning the weight gain during the first two years of life, described by the students. It is noticed that the group made a mistake in calculating the weight of a zero month baby, because instead of recording 5.2 kilos, it was recorded 5.6 kilos for such month. Moreover, the function shows a high value for the weight of boys at birth (0 months). Such issues, however, were discussed among the students and later by the teacher. Even the values obtained for the weight of a boy in the early years of life were not satisfactory, the group evaluated the model in a positive way by validating the data obtained by means of the described function for the following months.

5) The lesson is essentially constituted by the active participation of the students and teacher;

Some features of the proposed Modelling activity guaranteed the participation of students and the teacher, in the Group: the adoption of the theme by students, the mediation attitude of the teacher throughout the whole process.

To answer the questions about the Modelling problem, students had to delimitate the study situation. In a process of negotiation, the group chose to study the development of male babies according to their weight during the first years of life. Antônio said that they needed to study the development of boys in their first 12 months, considering the delimitation established by the group, to understand how would be these development in the subsequent months, whose data would not be provided in the Table 1: *“We intend to learn this difference until the 12th month to predict the following months. (...) Male, only. Because the system is the same”* (Antônio).

The group determining what would be studied within that broader situation proposed, indicated traces of feature 5, since this decision drove the class towards the mathematics used and the analysis of the results obtained by the group.

6) Learners and teachers could, for a while, see themselves as engaged in the same activity.

C6 refers to the concept of engagement. When Wenger (1998) deals with this concept, he explains that not every engagement is participation, because we can be participants in a practice, without necessarily be recognized for such practice. Frade (2003) says that, in the classroom, the students' engagement depends a lot on the opportunities given to them to negotiate experiences.

In the activity, students engaged to each other to resolve the problem by means of Mathematics. Antonio was more concerned to analyze the non-mathematical aspects of the problem, while Matias and Rosana were bothered to understand and explain the Mathematics involved.

This behavior favors individual's involvement in different social structures, which leads us to a broader discussion about the dimensions of affectivity and Mathematics (Hannula, 2012).

SOME CONSIDERATIONS

In this paper, we tried to demonstrate, by analyzing a classroom episode, how the learning environment of Modelling can contribute positively to the formation of LCoP in the classroom.

By the analyses of the negotiations held by a group of four students, we confirmed that the characteristics of the Modelling concept adopted in this paper, as well as their ways of conduction, promoted the dialogical interactions in the classroom, besides the mutual engagement of students in the proposed activity.

The environment afforded by the activity proves to be rich, since it provides students with discussions about the proposed situation, by means of their mathematical or non-mathematical experiences, letting them free to conduct discussions about other dimensions of the activity too. This was the case of Antonio. In this way, other voices in the classroom end up legitimized along with the teacher's. This is a fundamental aspect in the process of school learning (Frade, 2003), besides providing greater recognition and security for the participants of the shared practice.

Specifically in this activity, we verified that Matias was recognized as a leader by the colleagues, influencing the learning routes drawn by the others. Such recognition is due to the fact of the student cleverly lead discussions of mathematical nature, since was Mathematics class.

This study showed some relations of the formation of LCoP and the Mathematical Modelling, and made notes about how the emerging practices in this environment - intentionally designed by the educator - can encourage interactions and engagement of students in Mathematics class.

In addition, it is possible emphasize that the process of engagement, participation and recognition of mathematical competence, as described in this work, dialogues with researches about the social nature of affectivity in the learning process of Mathematics (Hannula, 2012)..

NOTES

1. The term “Modelling” will be used whenever we refer to “Mathematical Modelling in Mathematics Education”.
2. We Share here, the meaning of “practice” assigned by Wenger (1998). According to the author, “practice” means “do” something inside a historical and social context that gives structure and meaning for what is being done.
3. As the understanding of the concepts of domain, community and practice, and negotiation of meanings. For further information, see Wenger (1998).

4. The names listed here are fictitious. This is due to the resolution of the ethics council of the Estate University of Maringá, which requires the preservation of identities of the individuals involved in the research.

REFERENCES

- Barbosa, J. C. (2001). Modelagem na Educação Matemática: contribuições para o debate teórico. In: *Reunião Anual da ANPED*, 24., 2001, Caxambu. Anais. Rio Janeiro: ANPED, 1 CD -ROM.
- Barbosa, J. C. (2007). A prática dos alunos no ambiente de Modelagem Matemática: o esboço de um framework. In J. C. Barbosa, A. D. Caldeira, & J. L. Araújo (Eds.), *Modelagem Matemática na Educação Matemática Brasileira: pesquisas e práticas educacionais* (pp. 161-174). Recife, Brazil: SBEM.
- Barbosa, J. C. (2009). Mathematical modelling, the socio-critical perspective and the reflexive discussions. In Blomhøj, M., & Carreira, S. (Eds.), *Proceeding from Topic Study Group 21 at ICME-11* (pp. 133-143). Monterrey: IMFUFA tekst n. 461, Department of science, systems and models, Roskilde University.
- Boaler, J. (2001). Mathematical Modelling and New Theories of Learning. In *Teaching Mathematics and its Applications*, Vol. 20, Issue 3, p. 121-128.
- Brown, J., Collins, A., & Duguid, P. (1989). Situated Cognition and the Culture of Learning. *Educational Research*, 18(1), 1-32.
- David, M. S., & Watson, A. (2008). Participating in what? Using Situated Cognition Theory to illuminate differences in classroom. In Watson, A., & Winbourne, P. (Eda.). *New directions for situated cognition in Mathematics Education*, (pp. 31-57). Melbourne: Springer.
- Frade, C. (2003) *Componentes Tácitos e Explícitos do Conhecimento Matemático de Áreas e Medidas*. 241 f. Thesis (Doctorate in Education) - School of Education, Federal University of Minas Gerais, Belo Horizonte.
- Hannula, M. S. (2012). Exploring new dimensions of mathematics-related affect: embodied and social theories, *Research in Mathematics Education*, 14(2), 137-161, DOI: 10.1080/14794802.2012.694281
- Lave, J., & Wenger, E. (1991) *Situated Learning: Legitimate Peripheral Participation*. Cambridge: Cambridge University Press.
- Matos, J. F. (2003). A educação matemática como fenômeno emergente: desafios e perspectivas possíveis. *Conferência Internacional de Educação Matemática*. Vol. 11. Santa Catarina: Regional University of Blumenau.
- Skovsmose, O. (2000) Cenários de investigação. *Bolema – Boletim de Educação Matemática*, 14, pp. 66-91.
- Wenger, E. (1998). *Communities of Practice: Learning, Meaning, And Identity*. New York: Cambridge University Press.

- Wenger, E., McDermot, R., & Snyder, W. (2002). *Cultivating Communities of Practice*. Boston: Harvard Business School Press.
- Winbourne, P., & Watson, A. (1998). Participating in Learning Mathematics through Shared Local Practices in the Classrooms. In A. Watson (Ed.), *Situated Cognition and the Learning of Mathematics*, (pp. 93-104). Oxford: Centre for Mathematics Education Research of the University of Oxford.
- Winbourne, P. (2008). Looking For Learning in Practice: How Can This Inform Teaching. In Watson, A., Winbourne, P. (Ed). *New directions for situated cognition in Mathematics Education*, pp. 31-57. Melbourne: Springer.
- Zawojwski, J., Lesh, R., & English, L. (2003). A models and modelling perspective on small group learning activity. In R. Lesh, & H. Doerr (Eds.) *Beyond constructivism: Models and modeling perspectives on mathematics problem solving, learning and teaching*. (p. 337 – 358). Mahwah, NJ: Lawrence Erlbaum Associates.

COGNITIVE SCAFFOLDING FOR PROBLEM SOLVING: USE OF THE PRACTICAL WORKSHEET

Jaguthsing Dindyal, Eng Guan Tay, Khiok Seng Quek, Yew Hoong Leong,
Tin Lam Toh, Pee Choon Toh, Foo Him Ho

NIE, Nanyang Technological University

jaguthsing.dindyal@nie.edu.sg, engguan.tay@nie.edu.sg,
khiokseng.quek@nie.edu.sg, yewhoong.leong@nie.edu.sg, tinlam.toh@nie.edu.sg,
peechoon.toh@nie.edu.sg, foohim.ho@nie.edu.sg

In this paper, we elaborate on the use of the Practical Worksheet (PW) as a cognitive scaffold for students involved in problem solving activities. The PW is the outcome of our research team on problem solving. Rather than the teacher providing the scaffolding when students are not able to proceed further, we propose the use of the PW which contains prompts that help students to self-scaffold. The PW is also used along with a scoring rubric for assessing the students' progress at various stages of the problem solving process. We illustrate the use of the PW by a student and comment briefly on her solution.

INTRODUCTION

Problem solving is a valued component in school mathematics curricula in all parts of the world, although the extent to which it exists varies from country to country. Lester (2013) has characterized two approaches for instruction: (1) an *ends approach* that focuses on teaching for problem solving or (2) a *means approach* that focuses on teaching via problem solving. Lester added that the development of students' problem solving abilities is a primary objective of instruction whereby the teachers must decide on the problems and problem-solving experiences to use, when to give problem solving particular attention, how much guidance to give to students, and how to assess students' progress. As such, there is a heavy responsibility on the shoulders of the teachers in implementing school curricula focusing on problem solving.

On the other hand, for an individual involved in a problem solving activity, Schoenfeld (2010, 2013) has put forward a framework that accounts for:

1. the goals the individual is trying to achieve;
2. the individual's knowledge (and more broadly, the resources at his or her disposal);
3. the individual's beliefs and orientations (about himself and the domain in which he or she is working); and
4. the individual's decision-making mechanism.

From the above, the complexity of the problem-solving activity is quite evident, both, from the perspective of the teacher planning the instructional activities and the perspective of the individual learners involved in the problem-solving activity. In planning instruction, besides planning the problem solving tasks, teachers need to: (1) think about the help to give to students at strategic points in the problem-solving process; (2) ensure that students become self-directed learners and scaffold their own learning; (3) remind students of the important steps, such as “Checking and Extending”, usually overlooked by students; and (4) allocate enough credit to motivate students to complete the problem-solving tasks.

Our research team has identified several issues in the literature in the international context as well as those in the Singapore local context that need to be addressed to facilitate the implementation of problem solving in schools. Our approach still values the problem solving model of Pólya (1957) and the insights from Schoenfeld (1985). To aid in the implementation of problem solving in schools, we have come to the realization that the design of specific problems or problem solving tasks cannot be the only focus of problem solving but rather cognitive scaffolds (see Holton & Clarke, 2007) that allow students to solve a wider range of problems should also be an important focus.

Accordingly, in this paper, we focus on the design and use of the *practical worksheet* that can be used as a cognitive scaffold in problem solving tasks (see Figure 1). We highlight the development and use of the practical worksheet based on our design principles and feedback from teachers. We also illustrate the use of the practical worksheet by a student solving a non-routine problem in Singapore, where our research is carried out. The Singapore context is not highlighted here due to space constraints but will be presented at the conference

Cognitive Scaffolding

Holton and Clarke (2007) have claimed that scaffolding is an act of teaching that supports the immediate construction of knowledge by the learner and as well provides the basis for the future independent learning of the individual. These authors have added that scaffolding does not necessarily require the teacher and the student to be actually physically present together. Furthermore, it is essential for an individual student to be able to scaffold himself or herself when solving a new problem, termed *self-scaffolding* by the above authors.

In our research team, we conjectured that alongside a problem, the task for students should include a supporting document that would act as a cognitive scaffold for the students in the initial stages of the problem solving process before they could internalize the metacognitive strategies and automatically use these strategies when faced with a new problem. This is in line with the view that any scaffold should be gradually withdrawn as the learner becomes more competent (Rittle-Johnson & Koedinger, 2005; Yelland & Masters, 2007). We have followed Holton and Clarke’s (2007) ideas:

...cognitive scaffolding allows learners to reach places that they would otherwise be unable to reach. With the right word or question or other device a teacher may put in place the scaffolding that will allow new knowledge to be constructed, incomplete or wrong concepts to be challenged or corrected, or forgotten knowledge to be recalled. (p. 129)

Accordingly, our aim was to find a way of developing the learner's autonomy in taking charge of his or her own learning when faced with an unfamiliar mathematical problem whether the teacher was present or not. The artifact that we have developed is called the *practical worksheet*, which we have developed since 2005, to scaffold mathematical problem solving behavior in our efforts to teach mathematical problem solving in the schools. Figure 1 shows a typical response by a student in a test which used the practical worksheet and we have added a rubric for assessment. We have also incorporated ideas from Yelland and Masters (2007), who have also used the term cognitive scaffolding in the context of use technology use.

We have used the term *cognitive scaffolding* to denote those activities which pertain to the development of conceptual and procedural understandings which involve either techniques or devices to assist the learner. These include the use of questions, modelling, assisting with making plans, drawing diagrams and encouraging the children to collaborate with their partner. (p. 367)

The way a task is imagined and intended by the teacher may be quite different from the way it is construed and carried out by the students (see Mason & Johnston-Wilder, 2006). The intended learning by students may not happen if the tasks are misconstrued by them. Also, if teachers give too many directions then the solution process may become too trivial for the students and the solution process may be reduced to a sequence of steps. On the other hand, if the teachers give too few directions then the students may focus on different things and the implied learning may not happen. As such, the implementation of problem solving in the classroom ultimately hinges on the classroom teacher and in our designing process we paid careful attention to teacher preparation for problem solving including the use of the practical worksheet.

Levels of Scaffolding

Teachers in our project were taught how to use the following three levels of scaffolding: Pólya's stages, specific heuristics, and problem specific hints, which had to be used when advising students who were doing problem solving (Toh, Quek, Leong, Dindyal & Tay, 2011). The levels we have proposed are hierarchical in which the next level of scaffolding is suggested only after an earlier level has failed. For example, the Lockers Problem given below is quite well-known.

The Lockers Problem

A new school has exactly 343 lockers numbered 1 to 343, and exactly 343 students. On the first day of school, the students meet outside the building and agree on the following plan. The first student will enter the school and open all the lockers. The second student will then enter the school and close every locker with an even number. The third student will

then ‘reverse’ every third locker; i.e. if the locker is closed, he will open it, and if the locker is open, he will close it. The fourth student will reverse every fourth locker, and so on until all 343 students in turn have entered the building and reversed the relevant lockers. Which lockers will finally remain open?

We assume that students are familiar with the Pólya’s model for problem solving, which is emphasized throughout the problem solving lessons in our project. In Level 0, we emphasise the student learning and reinforcing of the Pólya model (see Table 1). We may ask the student some *control* questions, for example: whether he or she knows what Pólya stage he or she is in, and what would one normally do in such a stage. In Level 1, we suggest specific heuristics to get the work moving without making the heuristics too obvious for the problem under consideration. We propose to avoid Level 2 scaffolding as much as possible and is included only for the important aspect of ensuring that the self-esteem of the student is not seriously damaged by his or her perceived failure and helplessness on the problem. Here, we give problem specific hints, which essentially is comparable to the ‘usual help’ provided by mathematics teachers in classrooms.

Table 1. Levels of Scaffolding.

Level	Feature	Examples based on the Lockers Problem
0	Emphasis on Pólya stages and control	What Pólya stage are you in now? Do you understand the problem? What exactly are you doing? Why are you doing that?
1	Specific heuristics	Why don’t you try with fewer lockers (<i>use smaller numbers</i>)? Try <i>looking for a pattern</i> .
2	Problem specific hints	Think in terms of the locker rather than the student – which student numbers get to touch the locker?

The objective of the practical worksheet is for students to internalize Level 0, and ask for Level 1, and to a much lesser extent Level 2, hints only when pressed for time. Assessment of problem solving is certainly another issue that guides students in problem solving tasks. To this end, an accompanying assessment rubric was developed to focus students on what is valued in the problem solving process. At the same time, the rubric gives them feedback on their strengths and weaknesses.

Assessment Using the Scoring Rubric

One of the seven important principles that Lester (2013) has highlighted as emerging from his own research on problem solving is about assessment. He has stated:

The teacher’s instructional plan should include attention to how students’ performance is to be assessed. In order for students to become convinced of the importance of the sort of behaviors that a good problem-solving program promotes, it is necessary to use assessment techniques that reward such behaviors. (p. 273)

Traditionally, the assessment of problem solving in the classroom has focused on assessing the products rather than the processes of problem solving. Our efforts to meet the challenge of teaching mathematical problem solving to students call for a curriculum that emphasizes the processes (while not neglecting the products) of problem solving and an assessment strategy to match it so as to drive the mode of teaching and learning of mathematics.

It is common knowledge that most students will study mainly for curricular components which are to be assessed. Accordingly, there needs to be a corresponding assessment strategy that drives the teaching and learning of problem solving as described in the preceding paragraphs. Effective assessment practice begins with and enacts a vision of the kinds of learning we most value for students and strive to help them achieve. To assess the students' problem-solving processes (which we value), we developed a scoring rubric based on Pólya's model and Schoenfeld's framework.

The scoring rubric focuses on the problem-solving processes highlighted in the practical worksheet. There are four main components to the rubric, each of which would draw the students' (and teachers') attention to the crucial aspects of an attempt to solve a mathematical problem. In establishing the criteria for each of these components of problem solving, we ask the question, What must students do or show to suggest that (a) they have used Pólya's approach to solve the given mathematics problems, (b) they have made use of heuristics, (c) they have exhibited "control" over the problem-solving process, and (d) they have checked the solution and extended the problem solved (learnt from it)?

The rubric is outlined below. The complete rubric is not attached but will be presented at the conference.

- *Pólya's Stages* [0-10 marks] – this criterion looks for evidence of the use of cycles of Pólya's stages (Understand the Problem, Devise a Plan, Carry out the Plan), and correct solutions.
- *Heuristics* [0-4 marks] – this criterion looks for evidence of the application of heuristics to understand the problem, and to devise/carry out plans.
- *Checking and Extending* [0-6 marks] – this criterion is further divided into three sub-criteria:
 - Evidence of checking of correctness of solution [1 mark]
 - Providing for alternative solutions [2 marks]
 - Extending and generalizing the problem [3 marks] – full marks for this part is awarded for one who is able to provide (a) two or more problems with solutions or suggestions to solution, or (b) one significant related problem with comments on its solvability.

The rubric was designed to encourage students to go through Pólya stages when they are faced with a problem, and to use heuristics to explore the problem and devise a plan. They would return to one of the first three stages (see practical worksheet) upon

failure to realize a plan of solution. Students who show control (Schoenfeld's framework) over the problem-solving process gain marks. For example, a student who did not manage to obtain a completely correct solution would be able to score up to eight and three marks each for *Pólya's Stages* and for *Heuristics*, making a total of eleven, if they show evidence of cycling through the stages, use of heuristics, and exercise of control.

The rubric allows the students to score as much as 70% of the total 20 marks for a correct solution. However, this falls short of obtaining the top marks for the problem. The rest would come from the marks in *Checking and Extending*. Our intention is to push students to check and extend the problem (Stage 4 of Pólya's stages), an area of instruction in problem solving that has not been largely successful so far (see for example, Silver, Ghouseini, Gosen, Charalambous, & Strawhun, 2005).

DESIGN EXPERIMENT

We have used *design experiments* (Brown, 1992; Collins, 1999; Wood & Berry, 2003) as the methodological backbone of our project entitled Mathematical Problem Solving for Everyone (M-ProSE). Design experiments arose from the attempts of the education research community to address the demands of research in real-life school settings in all its complexity. It argues for the application of multiple techniques to study a complex phenomenon such as mathematical problem solving. This approach permits the use of several methods such as participant observation, interview, video-taping, and paper-and-pencil testing to provide corroborative evidence for findings. Gorard (2004) has claimed that the emphasis in design experiments is on a general solution that can be 'transported' to any working environment where others might determine the final product *within their particular context*. The envisaged outcome of M-ProSE was to produce a workable *design* (an initiative, artefact or intervention, for instance) that can be adapted to other settings.

Our aim has been to design a problem solving course that could be integrated in the regular school curriculum and prepare teachers to implement the course. Through several cycles of the design experiment, we have tried to refine the practical worksheet and set of problems to be used and as well as devised and fine-tuned an assessment rubric (described earlier) to go hand-in-hand with the practical worksheet. We have collected data from schools about teachers' implementation of problem solving using the practical worksheet as well as data from students using the practical worksheets during the problem solving process. The data include videotapes of classroom episodes, teachers' interviews, students' interviews as well as artefacts such as the practical worksheets collected from students and lesson plans from teachers. To illustrate the idea of cognitive scaffolding, we report the work of a female student about 15 years old who is working on a problem about timers (see Figure 1) by using the practical worksheet.

DISCUSSION OF A STUDENTS' SOLUTION

Solution of Student A Using the Practical Worksheet

M-ProSE

Problem

There are two timers: one for 5 minutes and one for 9 minutes. We want to heat a beaker of water for exactly 11 minutes. How can we do this using only these timers?

Instructions

- You may proceed to complete the worksheet doing stages I – IV.
- If you wish, you have 15 minutes to solve the problem without explicitly using Polya's model. Do your work in the space for Stage III.
 - > If you are stuck after 15 minutes, use Polya's model and complete all the stages I – IV.
 - > If you can solve the problem, you must proceed to do stage IV – Check and Extend.

I Understand the problem

(You may have to return to this section a few times. Number each attempt to understand the problem accordingly as Attempt 1, Attempt 2, etc.)

- Write down your feelings about the problem. Does it bore you? scare you? challenge you?
- Write down the parts you do not understand or that you misunderstood.
- Write down the heuristics you used to understand the problem.

Attempt 1

- I feel challenged, because I've done a similar question once, although it is simpler.
- None
- I noticed that 5, 9, 11 have no common factors, and I tried to do it mentally for a while to get the hang of it.

II Devise a plan

(You may have to return to this section a few times. Number each new plan accordingly as Plan 1, Plan 2, etc.)

- Write down the key concepts that might be involved in solving the question.
- Do you think you have the required resources to implement the plan?
- Write out each plan concisely and clearly.

Plan 1

1. Define variables (x and y)
2. Set up equations
3. Solve the equation
4. Relate back to problem
5. Offer solution

III Carry out the plan

(You may have to return to this section a few times. Number each implementation accordingly as Plan 1, Plan 2, etc., or even Plan 1.1, Plan 1.2, etc. if there are two or more attempts using Plan 1.)

- (i) Write down in the *Control* column, the key points where you make a decision or observation, for eg., go back to check, try something else, look for resources, or totally abandon the plan.
- (ii) Write out each implementation in detail under the *Detailed Mathematical Steps* column.

<i>Detailed Mathematical Steps</i>	<i>Control</i>
<p><u>Attempt 1</u></p> <p>Let the number of times the 5 minute timer is used by x, and the 9 minute timer be y.</p> <p>Therefore,</p> $5x + 9y = 11$ <p>By the Euclidian Algorithm,</p> $9 = 5 + 4$ $5 = 4 + 1$ $1 = 5 - 4$ $= 5 - (9 - 5)$ $= 2(5) - 9$ $11 = 22(5) - 11(9)$ $= 4(5) - 1(9) + 18(5) - 10(9) = 4(5) - 1(9)$ <p>Hence we have the result: $4(5) - 1(9) = 11$</p> <p>This means that the 5 minute timer is used 5 times, while the 9 minute timer is used only once.</p> <p>*Refer to attached paper</p>	<p>Define variables</p> <p>Setting up equation</p> <p>Solving the equation</p> <p>Relating back to problem</p>

IV Check and Extend

- (a) Write down how you checked your solution.
- (b) Write down your level of satisfaction with your solution. Write down a sketch of any alternative solution(s) that you can think of.
- (c) Give one or two adaptations, extensions or generalisations of the problem. Explain succinctly whether your solution structure will work on them.

Checking

If the water starts to be heated after the 9 minute timer, the 5 minute timer will have 1 minute left. Then the 5 minute timer is played 2 more times, totalling to $5 + 5 + 1 = 11$ minutes.

Alternative Solution 1

In order to form 11, we have the following ways:

$$2 + 9$$

$$5 + 6$$

$$2(5) + 1$$

$3 + 8$ } very low chance of being a solution, since it does not contain 5 nor 9.
 $4 + 7$ }

Hence our aim is to get 2, 6, or 1.

However, 5 and 9 are coprime, and through the Euclidian algorithm,

$$2(5) - 9 = 1$$

Now that we have 1, we just need to add 5 twice, and get 11.

$$4(5) - 9 = 11$$

By the same reasoning as part 3, the solution is to start both timers together, and retiming the 5 minute timer when it stops.

When the 9 min. timer stops, play start heating the water. The first time the 5 minute timer times out after start of heating, the water would have been heated 1 minute. Timing 5 minutes twice, we get 11 minutes.

Figure 1. Student A's solution using the practical worksheet.

We note that in her attempt to understand the problem, in attempt 1, Student A writes a note about feeling challenged and connects it to a problem she may have solved earlier. She also notices that 5, 9, and 11 have no common factors. We can say that, in some ways, the student is talking to herself. She is using her own control mechanisms to make sense of the problem that she has to solve. At the stage of devising a plan, she structures her thinking about using variables and writing equations. She actually writes an equation and solves it to get a sense of the solution to the problem. She then checks her solution and attempts to find an alternative solution. Unfortunately, she does not give an extension to the problem. However, her work on the practical worksheet illustrates quite convincingly how her solution was arrived at.

Student A did not ask for any scaffolding from the teacher but she delved into the solution all by herself. In other words, she underwent self-scaffolding. We note that Student A developed some procedural and conceptual understanding about the solution process as stated by Yelland and Masters (2007), which amounts to her cognitive scaffolding. Her work graded by using the assessment rubric will earn 16 out of 20 which amounts to 80% of the marks for this problem.

CONCLUSION

In this paper we have reported the use of the practical worksheet by only one student when she was solving one specific problem. However, the data from our research project do suggest that the practical worksheet holds promise for teachers who want to elevate problem solving to a prominent position in the mathematics classroom. Teachers can now not only encourage problem solving in their classes, in addition, they can make transparent to students the criteria for assessment and the processes that are valued during the problem solving process. Also, scaffolding need not always be carried out by the teacher during his or her physical presence and through oral discourse.

As mentioned throughout this paper, we strongly subscribe to the idea that the process of solving the problem is as important, if not, more important than the final solution of the problem. Accordingly, the assessment of problem solving should consider carefully the various stages of the problem solving process. Teachers should ensure that students earn enough credit for specific steps and for intermediate strategies that they use for solving problems. Altogether, our design experiment approach for this research on problem solving which amongst others, includes: the practical worksheet, an assessment rubric, a set of problem solving lessons, and teacher preparation, has shown great potential in developing student self-scaffolding in problem solving.

REFERENCES

Brown, A.L. (1992). Design experiments: Theoretical and methodological challenges in creating complex interventions. *The Journal of the Learning Sciences*, 2, 137-178.

- Collins, A. (1999). The changing infrastructure of education research. In E. C. Langemann & L. S. Shulman (Eds.), *Issues in education research* (pp. 15-22), San Francisco, CA: Jossey-Bass.
- Gorard, S. (2004). *Combining methods in educational research*. Maidenhead, England: Open University Press.
- Holton, D., & Clarke, D. (2007). Scaffolding and metacognition. *International Journal of Mathematics Education in Science and Technology*, 37(2), 127-143.
- Lester, F. K. (2013). Thoughts about research on mathematical problem-solving instruction. *The Mathematics Enthusiast*, 10(1&2), 245-278.
- Mason, J., & Johnston-Wilder, S. (2006). *Designing and using mathematical tasks*. St Albans: Tarquin Publications.
- Pólya, G. (1957). *How to solve it: A new aspect of mathematical method*. Princeton, NJ: Princeton University Press.
- Rittle-Johnson, B., & Koedinger, K. R. (2005). Designing knowledge scaffolds to support mathematical problem solving. *Cognition and Instruction*, 23(3), 313-349
- Schoenfeld, A. (1985). *Mathematical problem solving*. Orlando, FL: Academic Press Inc.
- Schoenfeld, A. H. (2010). *How we think: A theory of human decision-making with educational applications*. New York: Routledge.
- Schoenfeld, A. H. (2013). Reflections on problem solving theory and practice. *The Mathematics Enthusiast*, 10(1&2), 9-34.
- Silver, E. A., Ghouseini, H., Gosen, D., Charalambous, C., & Strawhun, B. T. F. (2005). Moving from rhetoric to praxis: Issues faced by teachers in having students consider multiple solutions for problems in the mathematics classroom. *Journal of Mathematical Behavior*, 24, 287-301.
- Toh, T. L., Quek, K. S., Leong, Y. H., Dindyal, J., & Tay, E. G. (2011). Assessing problem solving in the mathematics curriculum: A new approach. In B. Kaur & K. Y. Wong (Eds.), *Assessment in the mathematics classroom* (pp. 33-66). Singapore: World Scientific.
- Wood, T. & Berry, B. (2003). What does “design research” offer mathematics education? *Journal of Mathematics Teacher Education*, 6, 195-199.
- Yelland, N., & Masters, J. (2007). Rethinking scaffolding in the information age. *Computers & Education*, 48, 362-382.

AFFECTIVE ISSUES IN SOLVING CHALLENGING MATHEMATICAL PROBLEMS WITHIN AN INCLUSIVE COMPETITION

Rosa A. Tomás Ferreira*, Susana Carreira**, Nélia Amado**

* University of Porto & CMUP

**University of Algarve & Research Unit of the Institute of Education of the University of Lisbon,

rferreir@fc.up.pt, scarrei@ualg.pt, namado@ualg.pt

In this paper, we describe the behaviour patterns reported by the participants in a web-based problem solving competition of inclusive nature. In particular, we look at the help-seeking patterns to solve the problems and enjoyment and perceived difficulty in solving those problems. The results provide evidence of the challenging character of the competition problems, namely their moderate challenge degree. When seeking help, participants turn mainly to family members and teachers; in general, they enjoy solving the problems throughout the competition and find them of low or average difficulty. Regarding SUB12, there is evidence of a strong correlation between enjoyment and low perceived difficulty, as well as between enjoyment and no need to seek help. Yet, these tendencies are not fully found concerning participants in SUB14. Some questions for future research are raised.

RESEARCH GOALS

In recent years, we have witnessed an increasing number of mathematical competitions around the world, varying greatly in scope (regional, national, and international), form, contents, duration, and target population. Some competitions are aimed at highly talented students, while others have an inclusive character, welcoming all students, regardless of their mathematical problem solving skills.

Research has suggested that students' participation in mathematics competitions, especially at younger ages, positively influences their motivation to learn mathematics. In addition, participating in beyond-school mathematics competitions comprises positive affect towards mathematics and promotes the development of problem solving skills, regardless of students' success or difficulties manifested in school mathematics (Freiman & Vézina, 2006; Kenderov, Rejali, Bussi et al., 2009).

Inclusive competitions are aimed at all students. In such competitions, students are faced with challenging and exciting mathematics, which is perceived as accessible to average students, close to their daily lives, and socially and emotionally engaging. SUB12 and SUB14 are the two leagues of an inclusive mathematical problem solving competition, promoted by the University of Algarve. SUB12 is intended for 5th and 6th graders (ages 10-12) and SUB14 addresses 7th and 8th graders (ages 12-14), both

covering the southern region of Portugal. The two leagues are web-based, have similar rules and operate in parallel. This paper addresses the *Qualifying* phase of the competition in which participants have to solve 10 problems, released every two weeks. Participants may choose the approaches, strategies, representations and resources they wish to solve the problems, and they have to express clearly their thinking process. Formative feedback is provided to every answer and participants are allowed to resubmit their answers as often as needed until reaching a complete and correct solution, within the available time slot. Seeking help is explicitly encouraged by the organization.

Acknowledging the role of affective variables in the context of inclusive mathematical competitions, we intend to describe the behaviour patterns reported by the participants in SUB12 and SUB14 concerning their seeking for help to solve the problems throughout the *Qualifying* phase, and their enjoyment and perceived difficulty in solving those problems. We consider the following questions: (1) What is the significance of the help provided by the several partners that participants can resort to during the competition? (2) How do participants express themselves in relation to their higher or lower enjoyment with the various problems posed? (3) What is the participants' perception of difficulty regarding the problems? and (4) What trends can be identified combining these dimensions?

THEORETICAL PERSPECTIVES

Challenging mathematical problems

The relationship between affect and cognition has sparked considerable interest among researchers for a long time. Initially, affective factors were associated with causes for the effects on cognition. "Mathematics education, however, need not necessarily draw cognition and affect together by means of causal links alone. (...) affect, far from being the 'other' of thinking, is a part of it (...) The two interact" (Walshaw & Brown, 2012, p. 186).

A challenge is "a question posed deliberately to entice its recipient to attempt a resolution (...) A good challenge is one for which the person possesses the necessary mathematical apparatus or logical skill, but needs to use them in a nonstandard or innovative way" (Barbeau, 2009, p. 5). Students usually see good mathematical challenges as different from regular problem solving classroom activities, and even when they are perceived as not easy to grasp with, they stimulate feelings of pleasure and satisfaction (Jones & Simons, 1999). The notion of (good) challenge reflects how affect must be integrated with the cognitive aspects involved in it.

Mathematical competitions, especially those of inclusive nature, provide a privileged context for challenges beyond the classroom (Kenderov et al., 2009). The problems posed in SUB12 and SUB14 briefly and succinctly describe a context-framed situation, casting a well-defined question. However, they are expected to be seen by participants as challenges, which amounts to believing that students feel inwardly compelled to

solving them. Therefore, there is a delicate difference between the idea of mathematical problem and the concept of challenging mathematical problem. A *mathematical problem*, usually conceived as a situation from which the initial and the final states are known but the process to move from the first to the last is not immediately available through mathematical techniques and reasoning, has its grounds on the cognitive components of the problem solving activity. On the other hand, a *challenging mathematical problem* includes a strong affective appeal by involving curiosity, imagination, inventiveness and creativity, therefore resulting in an interesting and enjoyable problem not necessarily easy to deal with or to solve (Freiman, Kadjevich, Kuntz, et al., 2009).

Research has stressed the need for balance in the degree of challenging questions (or problems) posed to students (Schweinle, Turner, & Meyer, 2006) and the idea of *moderate challenge* has come to the fore (Turner & Meyer, 2004). The idea of moderate challenge needs to be complemented with features typical of challenge seeking contexts. One of them is viewing help seeking as legitimate and another is pressing for explanations and accountability for thinking. These two aspects are clearly present in SUB12 and SUB14: not only is help seeking explicitly encouraged, as reporting the solution process is required. The competition meets the conditions of environments that promote moderate challenge and shares the two essential categories that may describe challenge supporting practices: requiring accountability in demonstrating understanding and providing an emotionally supportive atmosphere for learning (Schweinle, Berg, & Sorenson, 2013; Turner & Meyer, 2004).

Students' help seeking and help avoidance

When a participant seeks help, can we assume that the problem was actually perceived as a challenge? If not, why? We suspect that the degree of difficulty of the problem may have been too high, leading to the need of seeking help. Moreover, the very act of asking for help can compromise the challenging character of the task in the eyes of the participants since the sense of achievement, namely if it is equated with performance demonstration, may not be as full – the credit for having answered well goes not just to the participant but is shared with others.

Help seeking has received increasing attention for its role in the learning process. Zusho and Barnett (2011) stress the social connotations of help seeking in tune with the costs involved: being perceived as needy and admitting failure or incapacity to accomplish a task. Thus, help avoidance is sometimes the consequence of a perception of threat to one's self-efficacy. Yet, there is evidence that self-regulated and confident learners are more likely to look for instrumental help: where the reasons to find help are the wish to learn and to understand the material, as opposed to a shortcut to get a task completed. In addition, low achievers tend to perceive greater threat in help seeking and therefore report higher levels of help avoidance; reversely, students with higher perceptions of cognitive competence show lower levels of help avoidance. "Taken together, these findings suggest a relatively strong link between students'

expectations of and confidence in academic success and patterns of help seeking and help avoidance” (Zusho & Barnet, 2011, p. 153).

Finally, patterns of help seeking are consonant with a caring, supportive and exploratory learning environment. This is also related to students’ perception of moderate challenge where conditions of support and accountability for understanding are nourished, and where a preference for challenging activities goes together with engagement and enjoyment. In such environments, students’ preference for solving problems on their own may rise and help seeking becomes closer to seeking clues rather than answers (Zusho & Barnet, 2011).

Students’ perception of task difficulty

How youngsters perceive task difficulty matures as they develop cognitively and socially. “Young children define ‘difficulty’ as a property endemic to the task (...), while older children cast greater complexity on the term, placing emphasis on how readily the task is accomplished by others” (Schweinle et al., 2013, p. 1). As age progresses, there is an increasing tendency to associate greater task difficulty with greater effort to accomplish and with lesser people who manage to fulfil it. Hence, there is “an inherent social comparison to perceptions of difficulty” (p. 3).

Although the ideas of challenge and difficulty have common features – for example, both require effort and involve a certain level of complexity – and are used frequently as synonyms, they are distinct. Schweinle et al. (2013) argue that “while value and importance are often attached to challenging activities, they are not necessarily attributes of all difficult activities” (p. 3). Thus, not all difficult tasks are challenging enough to those who approach them. In addition, “challenging tasks may encourage positive motivational orientations while difficulty ones may not” (p. 5). In the context of SUB12 and SUB14, all the proposed problems are challenging mathematical problems. They are not selected to be difficult tasks but rather to trigger participants to solve them, to engage with enthusiasm, to feel they are capable of reaching a solution which, nonetheless, may be a troubled process.

On the relationship between challenges and affect

Despite the realm of approaches to studying emotions and the various definitions that have come to the fore, there is large consensus about certain aspects of this construct. For example, emotions connect to personal goals: “they code information about progress towards goals and possible blockades as well as suggest strategies for overcoming obstacles” (Hannula, 2001, p. 61). Emotions “have an important role in human coping and adaptation” (p. 62), and are always present in human experiences. Yet, they become observable only when they are intense. When solving problems, people experience intensive emotions, whether of frustration or joy, for instance.

“The importance of a task and its link to student interest cannot be ignored as each relates to challenge” (Schweinle et al., 2013, p. 4). Students’ interest in a topic may influence their perception of challenge, thus, students’ disposition to pursuit a

challenge is fostered in learning environments in which the activities are seen as valuable and important.

Acknowledging the relative character of moderate challenges, there are indicators supporting the claim that such challenges promote the development of positive affect. Yet, a complex social environment around moderate challenges must be set: promoting feelings of enjoyment, pleasure and self-confidence as well as appreciation of mathematics; providing substantial formative and encouraging feedback which also serves to alleviate frustration, treat errors and misunderstandings as springboards for improvement, allow multiple opportunities to complete the tasks, and stimulate persistence; maximizing cooperation and minimizing competition and social comparison; emphasizing conceptual understanding and mathematical processes (Schweinle et al., 2006): “Optimal levels of challenge, coupled with affective and motivational support, can provide contexts most supportive of students’ feelings of enjoyment, efficacy, and value in mathematics” (p. 289).

The challenging environment of SUB12 and SUB14 meets these characteristics. The feedback that is provided to all participants, a key element in this competition, and ultimately its overall design contribute largely to its inclusive nature. Inclusion is, in fact, part of a wider goal of promoting enjoyment and pleasure in solving (challenging) mathematical problems.

METHODOLOGY

Data were collected through the participants’ answers to a mini-questionnaire consisting of three multiple-choice questions included in the online form available on the webpage to submit the answer to each problem. The answers were given by choosing a single option: i) I solved with the help of: a) Teacher; b) Family; c) Friends; d) SUB12 (or SUB14); e) Nobody; ii) I enjoyed the problem: a) Much; b) So-so; c) Little; and iii) I found the problem: a) Difficult; b) So-so; c) Easy.

Answering the questionnaire was mandatory when participants chose to use the online form to send their problem solution. Yet, the option of not responding to the mini-questionnaire items was ensured – problem solutions could be sent directly to the e-mail of SUB12 or SUB14, using the participants’ own personal e-mail account. Although participants could send several versions of a problem solution (drawing on the feedback that was always provided), only the answers to the mini-questionnaire relative to the last version of the solution were considered, even if there were changes in those answers throughout the swinging feedback process.

Usually, slightly less than 50% of the total number of participants answered the mini-questionnaire in each round of the competition. This number basically corresponds to those who used the online form to submit their answers. As the competition unfolds, the number of participants decreases (some are eliminated or just leave the competition) and so does the number of respondents to the mini-questionnaire (Figure 1).

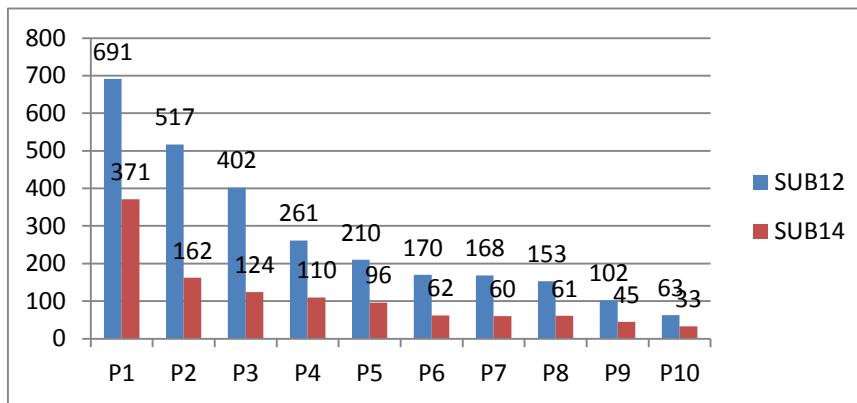

Figure 1. Number of respondents to the mini-questionnaire.

Our approach to analysing the data is mainly descriptive, based on the number of answers and percents regarding each option per problem. By looking at such values across the series of problems, the aim is to get a global picture that may indicate interesting aspects of children’s involvement in solving moderate challenging problems within the SUB12 and SUB14 competition.

DATA ANALYSIS

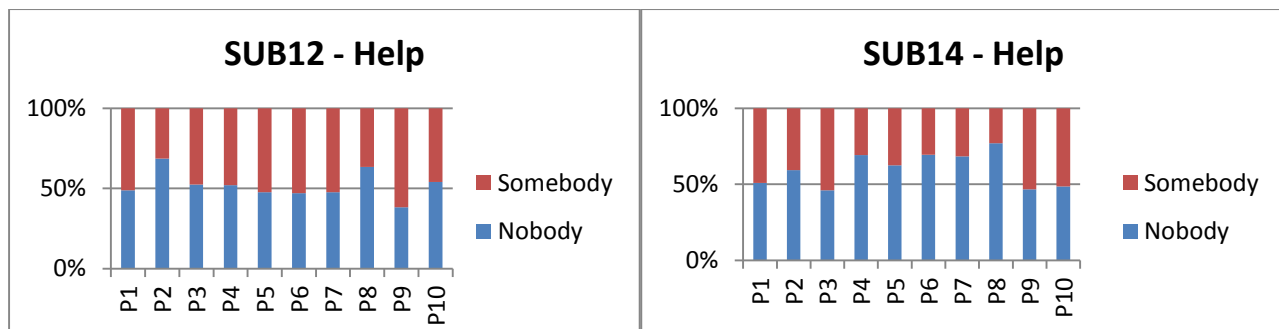

Figure 2. Help-seeking behaviour reported by participants in SUB12 and SUB14.

Figure 2 indicates how participants report on help seeking for each of the ten problems. As shown, help seeking was quite significant in the vast majority of problems, both in SUB12 and SUB14: the search for help was always indicated as higher than 46% except for problems 2 and 8 in SUB 12 – for which only 31,3% and 36,6% of participants sought help – and problem 8 in SUB14 – for which solely 23% of participants reported having asked for help. Participants felt a stronger need to ask for help in some problems: problem 9 in SUB12 and problems 3 and 9 in SUB14.

The two major sources of help are family members and teachers, for both SUB12 and SUB14 (Figure 3). Yet, the assistance of family members is not as expressive in SUB14 as it is in SUB12. It may well be that the same teacher is a source of help to a large number of participants – there are some teachers who reported in interviews that they give support to their students throughout the competition, and so the help of teachers may cover a lot of participants.

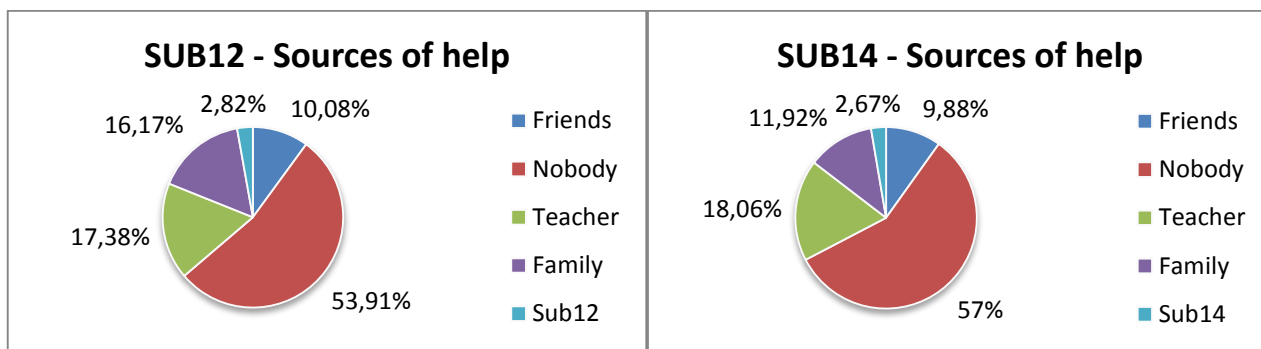

Figure 3. Overall sources of help reported by participants in SUB12 and SUB14.

The third source of help is the participants' friends, although the amount of inputs from friends is smaller in both leagues, especially SUB12. The participants' classmates may be included in the group of friends who provide them with help – for example, if the problems are solved in the school context (as we know is the case in several schools) or even if the problems are solved in group rather than individually.

Finally, the SUB12, or SUB14 (i.e. the organization of the competition to whom the participants contact by e-mail), is a residual source of help. However, all participants who sent an initial wrong or incomplete answer to each problem received feedback from the organization in order to reformulate their answer, and eventually this resulted in a correct solution. There is a discrepancy between the number of participants who claimed to have received help from SUB12 or SUB14 and the number of cases that actually succeeded after receiving feedback from the organization. A question then comes up: is it true that participants only recognize to have received help when they explicitly asked for it? There are only a few cases in which they take the initiative to seek the organization and ask for help, for example to start solving the problem. In these rare cases, participants do acknowledge the organization as a source of help.

Problems 3 and 9 (in SUB12) triggered a significant need for help. While problem 3 deals with geometrical topics, which typically pose some difficulties in school mathematics, problem 9 is related to numbers and regularities, a topic that is usually quite well received by students. Coincidentally, problems 3 and 9 in SUB14 also required more help but they do not deal with any particularly complex curricular topic. Therefore, help seeking may be problem dependent.

Figure 4 depicts the participants' perceived degree of difficulty of the challenges posed in the *Qualifying* phase. Problems 2 and 8 were considered as the easiest problems in SUB12, and these were also the problems for which the percentage of help sought was the lowest: 68,7% and 63,4%, respectively. Regarding SUB14, problem 4 was clearly the easiest one to solve but, though participants reported not having sought much help to solve this problem (69,1% did not use any help), it was not the one for which the lowest need for help was felt – that was problem 8, for which 77% of the participants declared not having had any help. Problems 3 and 9 in SUB12 stand out as the most difficult to solve: only 25,1% and 26,5% of respondents, respectively, considered them to be easy. Those problems also led the participants to seek significant help and did not

trigger feelings of enjoyment. Regarding SUB14, problems 2 and 9 were the most difficult ones, and these were also the least appreciated problems; problem 9 was the one triggering the highest need for help.

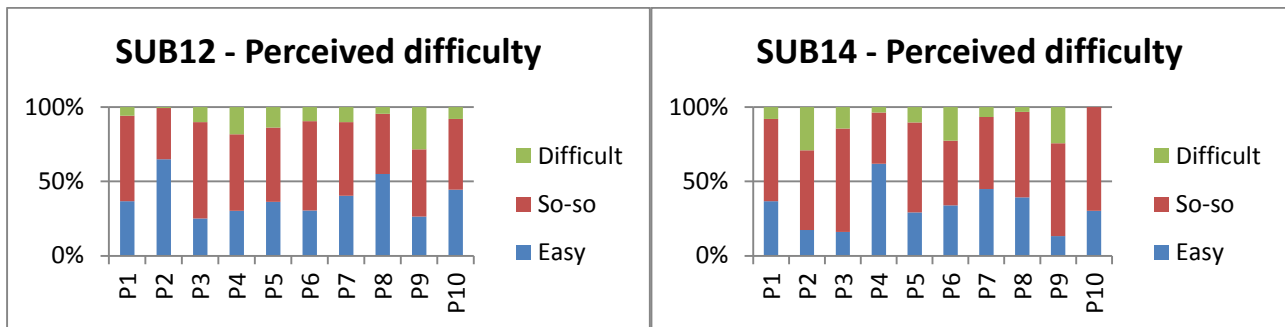

Figure 4. Perceived degree of difficulty reported by participants in SUB12 and SUB14.

In what concerns enjoyment, the overall manifested feeling shows a general positive emotion of participants in facing challenging mathematical problems (only 5,72% of participants in SUB12 and 9,07% in SUB14 report to have enjoyed little the problems). Nonetheless differences between SUB12 and SUB14 seem to exist. There are more participants in SUB12 reporting having enjoyed much the problems than in SUB14 (54,53% against 47,15%); at the same time, there are more participants in SUB14 reporting median or little enjoyment of the *Qualifying* problems. Moreover, the percentage of SUB14 participants who did not enjoy the problems (9,07%) almost doubles that of SUB12 participants (5,72%).

Looking at the reported enjoyment per problem, per league (Figure 5), it is easily noticed that in problems 3, 4 and 9 of SUB12 and 2 and 9 in SUB14, the number of answers stating “much enjoyment” is lower. At the same time, for these problems there is an increase in the number of answers indicating “so-so” and “little” enjoyment. These challenges are, in a sense, the deviants within the category of the enjoyment felt. Yet, the percentage of participants reporting “little” enjoyment is always below 13% for SUB12 and 20% for SUB14, which is consistent with an overall lower enjoyment of the problems on the part of SUB14 participants.

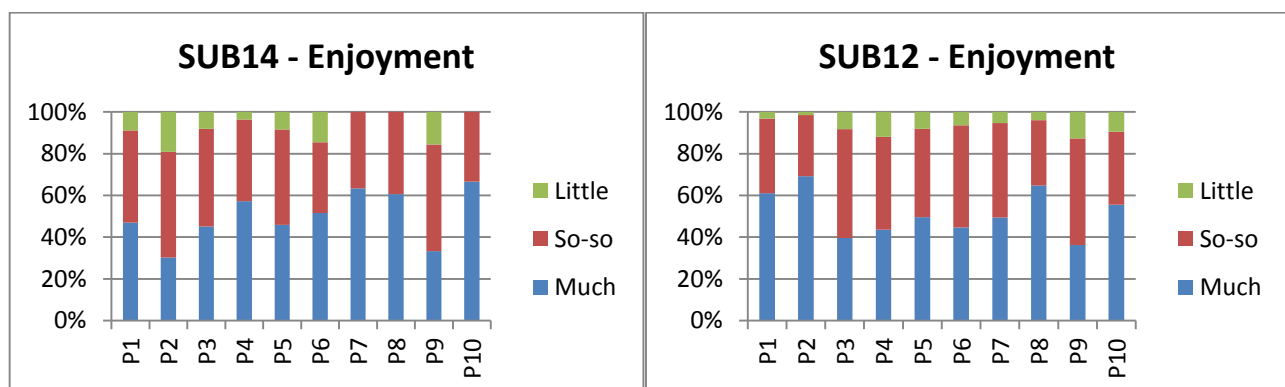

Figure 5. Degree of problem enjoyment reported by participants in SUB12 and SUB14.

Problem 9 in SUB12 is the one that triggered the highest need for help and the one participants enjoyed the least. It was also reported as one of the most difficult problems.

The complexity of this problem may be associated with a smaller degree of enjoyment. Yet, this greater difficulty may also indicate that the challenge was higher and therefore such over-challenge led to lowering the feeling of enjoyment. Problem 9 in SUB14, which is the one with the lowest degree of reported enjoyment, though also associated with the highest help-seeking behavior, does not exhibit such a strong relationship between enjoyment and help-seeking as its SUB12 counterpart.

The overall perceived difficulty of problems exhibits some differences between the leagues. The percentage of participants in SUB14 considering the problems as having median difficulty (54,8%) or being actually difficult (12,46%) is generally higher than that of participants in SUB12 (51,19% and 8,65%, respectively).

By crossing the data about the three affective issues that we consider in this paper – help-seeking behavior, level of enjoyment and perceived degree of difficulty of all the problems throughout the *Qualifying* phase of SUB12 and SUB14, we can identify some trends and some similarities and differences between the two leagues. For example, it is not surprising (it is even expected) to find a positive correlation between finding a problem to be *difficult* and feeling the need to seek *help* ($\rho=0,78$), as well as a negative correlation, also significant, between finding a problem to be *easy* and searching *help* ($\rho=-0,85$). This is the case for SUB12.

However, it is not possible to find similar correlations in SUB14. In fact, like in SUB12, finding a problem to be easy and searching for help are correlated negatively but with distinct strength: the relationship is not as strong in SUB14 ($\rho=-0,66$) as it is in SUB12 ($\rho=-0,85$). But the most striking difference is related to the association of seeking help with finding a problem to be difficult. While in SUB12 the correlation of these two dimensions is significant ($\rho=0,78$), in SUB14 we cannot even consider those dimensions to be correlated ($\rho=0,21$). Nevertheless, asking for help is welcome among the participants in both SUB12 and SUB14. Asking for help when feeling difficulties in solving the problems is also natural for the younger participants but not really relevant for the older ones.

Our data suggest that, in SUB12, there is a strong positive correlation ($\rho=0,91$) between *enjoying much* a problem and finding it *easy* and between *enjoying little* a problem and finding it *difficult* though not as strong as the former ($\rho=0,88$). This latter relationship is even stronger for participants in SUB14 ($\rho=0,95$). However, for participants in SUB14, finding a problem *easy* is not strongly correlated to *enjoying it much* ($\rho=0,69$). A possible explanation for these situations of strong correlation may be related to the fact that there might exist participants who do not enjoy a problem despite finding it easy to solve – some may even find the problem too easy to bother. Yet, this is not a common situation, at all.

When we consider a median enjoyment of the problems, we find more differences between SUB12 and SUB14. Participants in SUB12 who find the problems of median difficulty tend to enjoy them averagely ($\rho=0,67$). Yet, those in SUB14 do not make such associations. These correlations seem to indicate that the enjoyment of a problem

tends to be less associated with the easiness in solving it as the age of participants increases. In SUB12, *enjoying much* a problem is positively correlated with *not* feeling the need to *ask for help* ($\rho=0,79$). However, we do not find a similar situation regarding SUB14. In fact, there is no correlation between enjoying much, averagely or little a problem and needing help from someone to solve it ($\rho= -0,41$; $\rho= 0,45$; and $\rho= 0,3$; respectively).

DISCUSSION AND CONCLUSIONS

As research suggests help seeking is an important matter in any learning context, and even more relevant within an inclusive mathematical competition. In the case of SUB12 and SUB14, participants are explicitly encouraged by the organization to ask for help when facing obstacles in solving the challenges. Our data indicate that participants feel at ease to ask for help to solve the problems. The help provided by the various sources contributes to the participants' success throughout the *Qualifying* phase and their sense of accomplishment; in addition, it positively influences the number and diversity of students who decide to participate in the competition.

There are two main sources of help: teachers and family members. This signals a great family involvement alongside with a presence of the competition in the school environment, reinforcing and extending previously found results (Carreira et al., 2012, 2013). Nevertheless, the significance of family members' assistance is lower in SUB14 in comparison to SUB12. It is very likely that the same teacher is the source of help for a big number of participants – several teachers revealed frequently supporting their students' participation during the competition; thus, this source of help may cover a large number of participants (Carreira et al., 2012, 2013). Further research should follow to better understand how students perceive help seeking according to the different available sources, in particular the very own organization of the competition. This source of help is especially intriguing since it seems to be recognized as such only when participants specifically ask for it (cf. Carreira et al., 2013). Furthermore, participants may not acknowledge the feedback that is always provided as an actual source of help, perhaps because it is offered, not requested. In general, the participants may not perceive the feedback constantly provided by the organization as actual help since such feedback is offered without being requested; it arises as a reaction (and is possibly seen as corrective stance rather than a means to help improving the work already done) to the answer sent by the participants. The fact that all the communication established between the participants and the organization is at a distance may also condition the perception of the organization as a source of help – it is more distant from the participants than other, handier sources.

In general, participants do enjoy the problems of the *Qualifying* phase of the competition. We believe that most of these problems can be considered of moderate challenge (Turner & Meyer, 2004). This seems to resonate with prior studies which indicate that the challenging and competitive nature of activities like SUB12 and SUB14 is associated with a positive affect towards mathematics and developing

problem solving skills (Kenderov et al., 2009). Yet, despite the overall tendency, in relative terms, more participants in SUB12 enjoy much the problems than those in SUB14; at the same time, more participants in SUB14 enjoying little the problems than those in SUB12.

In both leagues, some problems may have been too challenging. For example, problem 9 in SUB12 and problems 2 and 9 in SUB14 stood out as being particularly difficult to solve. These problems were also indicated by the participants as having gathered a lower level of enjoyment. The problems' over-challenge may have lowered the level of enjoyment reported by the participants. Enjoyment may also depend on how participants perceive the value and interest of a problem. If those problems were not perceived as interesting to the eyes of participants, they may have not seen them as challenges, as Schweinle et al. (2013) suggest. In addition, participants may confuse enjoying a problem with reaching (or being able to reach) a solution. This may distort the data collected. Further research with a qualitative approach may help in better understanding these issues.

In general, participants find the problems to be easy or with median difficulty. However, in relative terms, more participants in SUB14 report finding the problems to be difficult or of median difficulty than those in SUB12.

It is possible to find some strong associations among the affective dimensions of participating in the competition considered in this paper. For example, enjoying little a problem is strongly correlated with finding it difficult to solve in both leagues. The correlations that were found among the data seem to meet Turner and Meyer's (2004) suggestions, providing evidence that the problems posed throughout the *Qualifying* phase of SUB12 and SUB14, in general, are challenging mathematical problems and of moderate challenge. They also support the claim that the design of SUB12 and SUB14 is consistent with practices that promote the development of problem solving skills. At the same time, enjoying much a problem is highly associated with finding it easy to solve, especially for participants in SUB12; this association is clearly not as strong for participants in SUB14. The age level of the latter, who are more mature than the former, may explain the differences found, as well as a possible larger experience in participating in the competition on the part of those enrolled in SUB14. This tendency may be related to the increasing maturity of the participants but it may also be due to other factors such as experience in participating in the competition. Indeed, many participants in SUB14 were enrolled in the SUB12 league of the competition and this experience may have taught them that not so easy problems also trigger enjoyment in the problem solving process. Participants in SUB14 may have developed the perception that the feeling of enjoyment in solving problems goes beyond the easiness in that process. Taking this into account, our data corroborates, in general, the connection among the inclusive nature of the competition, the moderate character of the challenges proposed and the positive affect around mathematical problem solving (Freiman & Vézina, 2006).

Finding a problem to be easy is negatively correlated with seeking help to solve it. This relationship is much stronger for SUB12 than for SUB14. On the other hand, finding a problem to be difficult is positively correlated with searching for help in order to solve it but this is so only for participants in SUB12; those in SUB14 do not report this association. Asking for help seems not to diminish the sense of self-efficacy, even when facing more difficult challenges, especially in SUB12.

In SUB12, the problems where the level of enjoyment lowers are precisely those for which participants seek most help. Yet, this is not the case in SUB14: enjoying much a problem is not associated with not feeling the need to search for help. It might well be that, as youngsters grow older, feeling the need to ask for help does not affect the level of enjoyment of the problem in question. The participants' experience in various editions of the competition may also contribute to this perception of enjoyment versus need to seek help.

In this study, although the participants could send several answers to the problems and reply to the mini-questionnaire differently in each submission, we considered only the responses to that instrument concerning the last submitted version of the problems' answers. We recognize that, despite our efforts to provide formative and encouraging feedback to an incorrect or incomplete answer, the very fact of receiving such feedback bears evaluative information as well – the participant is informed about the correctness and comprehensiveness of the submitted answer, and this may change how he or she perceives the problem degree of difficulty or how he or she enjoys solving the problem at hand. Further research should look more carefully to the evolution of responses to the mini-questionnaire when more than one version of the problem answer is involved to shed light into the influence of feedback in those affective issues.

NOTES

1. This work is supported by national funds through Fundação para a Ciência e Tecnologia, under the projects PTDC/CPE-CED/101635/2008 and PEst-C/MAT/UI0144/2013, and by FEDER funds through COMPETE.

REFERENCES

- Barbeau, E. (2009). Introduction. In E. J. Barbeau & P. J. Taylor (Eds.), *Challenging Mathematics In and Beyond the Classroom. The 16th ICMI Study* (pp. 1-9). New York, NY: Springer.
- Carreira, S., Amado, N., Tomás Ferreira, R. A., Silva, J. C., Rodriguez, J., Jacinto, H., Amaral, N., Nobre, S., Martins, I., Reis, S., & Mestre. R. (2012). *Um olhar sobre uma competição matemática na Web: Os SUBs*. Faro: Universidade do Algarve – Projeto Problem@Web.
- Carreira, S., Tomás Ferreira, R. A., & Amado, N. (2013). Young students solving challenging mathematical problems in an inclusive competition: Enjoyment vis-à-vis help-seeking. *CERME8*, Antalya, Turkey.

- Freiman, V., Kadjevich, D., Kuntz, G., Pozdnyakov, S., & Stedøy, I. (2009). Technological Environments beyond the Classroom. In E. J. Barbeau & P. J. Taylor (Eds.), *Challenging Mathematics In and Beyond the Classroom. The 16th ICMI Study* (pp. 97-131). New York, NY: Springer.
- Freiman, V., & Véniza, N. (2006). *Challenging Virtual Mathematical Environments: The Case of the CAMI Project*. Pre-conference paper of the Study Conference for ICMI Study 16 – Challenging Mathematics In and Beyond the Classroom. Retrieved from <http://www.amt.edu.au/icmis16pcanfreiman.pdf>.
- Hannula, M. (2001). The metalevel of cognition-emotion interaction. In A. Ahtee, O. Björkqvist, E. Pehkonen, & V. Vatanen (Eds.), *Research on mathematics and science education: From beliefs to cognition, from problem solving to understanding* (pp. 55-65). Finland: University of Jyväskylä, Institute for Educational Research.
- Jones, K., & Simons, H. (1999). *Online Mathematics Enrichment: An evaluation of the NRICH project*. Southampton: University of Southampton.
- Kenderov, P., Rejali, A., Bussi, M., Pandelieva, V., Richter, K., Maschietto, M., Kadjevich, D., & Taylor, P. (2009). Challenges Beyond the Classroom – Sources and Organizational Issues. In E. J. Barbeau & P. J. Taylor (Eds.), *Challenging Mathematics In and Beyond the Classroom. The 16th ICMI Study* (pp. 53-96). New York, NY: Springer.
- Schweinle, A., Meyer, D. & Turner, J. (2006). Striking the Right Balance: Students' Motivation and Affect in Elementary Mathematics. *Journal of Educational Research*, 99(5), 271-293.
- Schweinle, A., Berg, P. J., & Sorenson, A. R. (2013). Preadolescent perceptions of challenging and difficult course activities and their motivational distinctions. *Educational Psychologist*. DOI:10.1080/01443410.2013.785049.
- Turner, J., & Meyer, D. (2004). A Classroom Perspective on the Principle of Moderate Challenge in Mathematics. *Journal of Educational Research*, 97(6), 311-318.
- Walshaw, M., & Brown, T. (2012). Affective productions of mathematical experience. *Educational Studies in Mathematics*, 80(1-2), 185-199.
- Zusho, A., & Barnett, P. (2011). Personal and contextual determinants of ethnically diverse female high school students' patterns of academic help seeking and help avoidance in English and mathematics. *Contemporary Educational Psychology*, 36(2), 152-164.

IDENTIFYING COGNITIVE-AFFECTIVE INTERACTION PHENOMENA IN A TECHNOLOGICAL MATHEMATICAL CONTEXT

Inés M. Gómez-Chacón

Mathematics Faculty, Complutense University of Madrid, Spain

igomezchacon@mat.ucm.es

The increase in the power of technology is accompanied by an increase in the complexities of its integration into the classroom. Researchers are becoming ever more sensitive to the key factors associated with this problem and how these factors interact with cognitive and affective aspects when the device used becomes a means by which to do mathematics. The research on the interaction between affect and cognition described in this paper is focused on understanding the role played by emotion in personal learning within the context of the use of technology in mathematics. The study revealed the existence of several emotional phenomena associated with technology-assisted learning, which appear to be closely linked to initial attitudes and a preference for visual reasoning. In addition, the results show a relationship between affective reactions and cognitive technical competence.

INTRODUCTION

The amount of research concerning cognition-affect interaction in mathematical education has increased in the last few decades. We can find many different kinds of studies. Among them are remarkable studies on learning and affect tend to refer either to the affective reactions that may have a bearing on cognitive and conative processes (DeBellis & Goldin, 2006, Goldin, 2002, Gómez-Chacón, 2000, 2011) or to the so-called directive processes (metacognitive and meta-affective processes) involved in the development of mathematical thinking (creativity and intuition, attribution, visualization, generalization processes and similar) (De Corte, Depaepe, Op 't Eynde, and Verschaffel, 2011, Gómez-Chacón, 2012). Others address the ways that emotions impact cognitive processing, such as the bias introduced in attention and memory and the encouragement of a tendency to act (Schlöglmann, 2002). Emotions have also been seen to play a key role in human coping mechanisms and adaptation (DeBellis & Goldin, 2006; Hannula, 2002, Gómez-Chacón, 2011).

These studies focus, on the one hand, on students' emotions during problem solving and on the other on the importance of cognition-affect interaction pathways in the construction of mathematical knowledge. However, in-depth exploration of the underlying structural concept, from which conclusions for improving teaching might be drawn, has yet to be addressed. In order to understand this structural concept in the construction of mathematical knowledge we focus on interplay between cognition and affect in computerized environments.

Several theoretical approaches to the analysis of interplay between cognition and affect have been adopted in this research. One such approach is to view affect through the lens of a representational system (Goldin, 2002, Gómez-Chacón, 2000). Affective pathways are sequences of (local) emotional reactions that interact with cognitive configurations in problem solving. Such pathways provide solvers with useful information, favoring the learning process and suggesting heuristic problem-solving strategies. With regards to the mathematical cognitive aspects in a technological environment, we used the theoretical geometric work space (Gómez-Chacón & Kuzniak, 2013) and Artigue's (2002) instrumental approach to describe the complexity involved in applying technology to geometric tasks.

Whereas most studies adopting an instrumental approach have analyzed the development of technological usage schemes in their cognitive and institutional dimensions (Artigue, 2002), the present research is focused on the cognition-affect inter-relationship in pursuit of an understanding of the role played by emotion in personal learning. Affect is believed to play an important role in the conversion of artefact into mathematical instruments, inasmuch as a positive or negative attitude toward computers (for instance) may influence how cognitive and instrumental schemes develop.

This contribution explores this perspective. It forms part of an on-going national project of experimentation, set up in 2006, the aim of which is to determine which affective or belief systems connect to specific mathematical processes and how they impact personal and collective learning. The chosen sample consisted of Spanish mathematics undergraduates planning to become secondary school math teachers. Two studies were developed as part of this project. The first study concerns cognitive-emotional interactions in the context of technology-assisted learning, identifying the emotional typologies and phenomena experienced by subjects. The second focuses on meta-emotion and the cognitive-emotional processes that characterize interactive visualization in technology-assisted problem-solving situations. A joint description of both studies appears in a chapter of the book (Gómez-Chacón, 2014, print) which focuses on updating theoretical frames and empirical studies in the field concerning beliefs and affect in mathematics education.

In this paper we focus on the first study the aim of which is to identify the cognitive-emotional phenomena that impact the appraisal of technology usage and to be able to describe subjects' general personality traits by recognizing the attitudes, emotions, preferences, beliefs and cognitive-instrumental difficulties that they express.

The research questions posed in the present study were as follows. What are students' initial attitudes? What levels of self-confidence in, motivation for and engagement with mathematics can be observed in technological learning environments? During teaching experiment, what causal relationships between emotions, cognitive processes expressed as cognitive difficulties and attitudes were observed?

The present findings contribute to this line of research by providing empirical data on the causal relationships between emotions, cognitive processes expressed as cognitive difficulties and attitudes toward technology. The results demonstrated that these are highly context-dependent. The results also highlighted the importance of visualization in understanding and solving problems and showed that visualization may be associated with varying emotions and beliefs. Furthermore, the combined methodology (survey and teaching experiments) proposed has been shown as an effective method of solving the research challenge of identifying individual patterns related to the dynamics of affect.

METHODOLOGY AND DATA ANALYSIS

The population consisted of 98 (65 women and 33 men) Spanish undergraduates working toward a BSc. in mathematics with a view to becoming secondary school math teachers.

The survey used an adapted version of the instruments (Likert-type attitudes scales) developed by other researchers (Galbraith and Haines, 2000) to evaluate attitudes toward mathematics and technology, along with a specific questionnaire to determine preferences for visual reasoning and feelings about computers (Gómez-Chacón, 2012). These instruments covered both feelings and opinions about the use of technology to learn and use mathematics. The questionnaire posed questions such as the following. Is visual reasoning central to mathematical problem solving? Justify your reply and provide examples. Describe your feelings about the use of problem representations or visual imagery. Describe your emotional reactions and specify whether you hit a mental block when doing the problem with pencil and paper or with a computer. Do computer graphics help you learn mathematics?

Attitude assessments were supplemented with observations during teaching experiments (Gómez-Chacón & Kuzniak, 2013) such as described below. The problem posed to students in this example was worded as follows.

Enlarge the following bell in such a way that $A'H'$ measures twice AB . Draft a procedure for solving the problem. Here are a few clues that might help you draw the bell.

1. Note that A lies on both line BI and line CJ .
2. H is the mid-point on line BC .
3. Angles IBC and JCB measure 60° .
4. Angles BIC and CJB are right angles.
5. BC is an arc of a circle whose center is A .

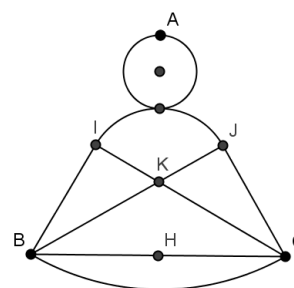

The “bell” exercise was a two-session task. In the first, students were given the problem and asked to describe their approach to its solution, including in the protocol the steps involved, their emotions and the difficulties encountered. The second session was

devoted to working on the enlarged bell and discussing common approaches as well as any emotional difficulties that arose.

Different groups of items required different statistical methods. 1) Likert-type scale attitudes were analyzed with SPSS software, which computed the means, standard deviation and internal consistency (Cronbach's α) for each of these sub-scales of the survey (based on a 5-point Likert scale, from 1 to 5); the correlation between attitude scales; the factor pattern matrix; and clusters. 2) The open-ended questions concerning the most and least preferred method of visual reasoning, computer-related emotions and cognitive learning difficulties in technology-assisted mathematics work were coded by qualitative data processing using content analysis to define the categories listed below. Frequency values were computed by two researchers. 3) Similarly, all categories were compiled and coded in a matrix for implicative analysis performed using CHIC software.

This implicative analysis (Gras et al., 1997) was used to explore structure in cognitive-affect interactions. This statistical analysis allowed to establish rules of association for data series in which variables and individuals were matched to define trends in sets of properties on the grounds of inferential, non-linear measurement. This non-symmetrical statistical approach draws from the notion of implication, borrowed from Boolean algebra and artificial intelligence. Knowledge is formed inductively after a number of successful attempts ensure a certain level of confidence in a given rule. As soon as this (subjective) level is reached, the rule is accepted and implemented.

According to Gras (Gras et al., 1997), learning begins with inter-related facts and rules that progressively form learning structures. That is precisely the aim of the present study, to find rules that reduce the number of categories (listed below) while furnishing information on the factors involved in the cognition-affect structure. Grass defines three important rules that can be described in learning processes: 1) $a \rightarrow b$, where a and b may be categories or rules; 2) $a \rightarrow (b \rightarrow c)$; and 3) $(a \rightarrow b) \rightarrow (c \rightarrow d)$. These rules describe a hierarchical, oriented and non-symmetrical learning structure, that can be obtained with cohesive hierarchical implicative classification (CHIC) software (Bodin, Coutourier, & Gras, 2000). The result is three types of diagrams that contain different types of information. a) Similarity trees group variables on the grounds of their uniformity, allowing for interpretation of the groupings with which the variables are handled. Each level on the resulting graph contains groups arranged in descending order of similarity. b) Hierarchy trees are used to interpret classes of variables defined in terms of significant levels along the lines of similarity, identifying association rules and levels of cohesion among variables or classes. c) Implication graphs are constructed around both an intensity index and a validity index to show associations among implications that are significant at specific levels.

The following categories were defined for implication analysis:

- *Emotions regarding computer (GeoGebra) use*: Positive (EmoP), Negative (EmoN), depend on the task and activity (Emodep).

- *Preference for visual reasoning*: VisualA (like); VisualN (indifferent); VisualD (dislike)
- *Attitudes toward mathematics and technology*: self-confidence in mathematics (mathconf), mathematical motivation (mathmot), mathematics engagement (matheng), computer motivation (compmot) and interaction between mathematics and computers (mathcompuint).
- *Cognitive learning difficulties in the bell exercise*: The difficulties on which the study focused were: understanding and interpreting the problem in the initial phase of problem solving (CD1); difficulties in connection with the relationship between the vision of the object and visualization (CD2); instrumental genesis (software commands and mathematical meaning or the dependencies between objects in geometry dynamics (CD3); and blockage in overall control of the geneses involved in geometric work (blockage in the switch from discursive to instrumental or blockage due to the complexity of homothetic discernment) (CD4).

RESULTS

The findings are discussed below and are divided into three sections, the first discusses attitudes toward mathematics and technology, the second certain cognitive-emotional processes underlying mathematical attitude during teaching experiments and their causal relationship, and, the last section describes the effect of emotional regulation and on task performance.

Attitude toward computer-assisted mathematics

This group showed an initially satisfactory (medium-high) attitude, i.e., appropriate disposition from the outset, characterized by dimensions such as self-confidence, motivation, engagement with learning, and positive beliefs about mathematics and computer-enhanced mathematics learning. The dimensions measured with the questionnaire were: self-confidence in mathematics (mathconf), mathematical motivation (mathmot), mathematics engagement (matheng), computer motivation (compmot) and interaction between mathematics and computers (mathcompuint). The mean values for these dimensions were similar in this group, although statistically significant differences were found among the standard deviations at a 95.0 % confidence level (Table 1).

These students' belief that computers enhance mathematical learning was illustrated with examples. They found note-making helpful to supplement screen-based information, and reviewed their notes soon after each computer session. They also felt that computers help associate algebraic and geometric ideas. That they were motivated to use computers was obvious from their opinion that they make learning more enjoyable. They also liked the experimental freedom afforded by computers, claimed to spend long hours in front of the monitor to complete a task, and appreciated the ability to test new ideas thanks to computers.

Table 1. Mean, standard deviation and internal consistency (Cronbach's α) for each sub-scale.

	Mathconf	Mathmot	Matheng	Compmot	Mathcomp uint
Mean	3.32	3.53	3.41	3.41	3.41
Standard deviation	0.48	0.69	0.65	0.65	0.50
(Cronbach's α)	0.77	0.80	0.57	0.82	0.69

Contextualized cognitive processes and emotions: analysis to teaching experiments

Together with the attitudes observed in future teachers, their answers respecting their emotions when solving mathematical problems with a computer were analyzed to attempt to answer the question: what cognitive-emotional processes govern students' positive or negative appraisal of the use of GeoGebra to learn mathematics? Positive emotions were described by 52.6 %, negative emotions by 19.6 % and 27.8 % replied that they could not give a general answer, for their emotions were task-specific. A26, for instance, replied:

“It depends on the task and the software. Generally speaking, I like the resources it provides (especially for complex or dynamic depictions). And the fact that it simplifies operations (in astronomy, for instance) is very handy. But I find some sorts of computer-aided mathematics less appealing, mostly because of the math itself, not the computer” (A-26-GD-E2).

The frequency of emotional categories varied, partly depending on task typology. On the whole, the emotions that students reported as obstructions to learning were lack of self-confidence and apprehension, which respectively accounted for 15 and 25 % of all the responses. The reasons were mental blockage around the use of the tool and the application of mathematical knowledge with the software: *“At first you feel overwhelmed when you don't know how to apply your mathematical knowledge with the tools that perform these operations”* (A18-GA-E2). Frustration and disappointment were other negative emotions frequently reported in retrospect, attributed to an uncertain command of the technical language or the time that had to be devoted to solving the problem.

These results reinforce the situational and contextual nature of the emotions felt. The characteristics of the contextualized cognitive-effective structure could be explored by applying implication analysis to teaching experiments such as the “bell” exercise.

Figure 1 shows the similarity analysis findings. The variables (listed in item 2) were grouped into three classes.

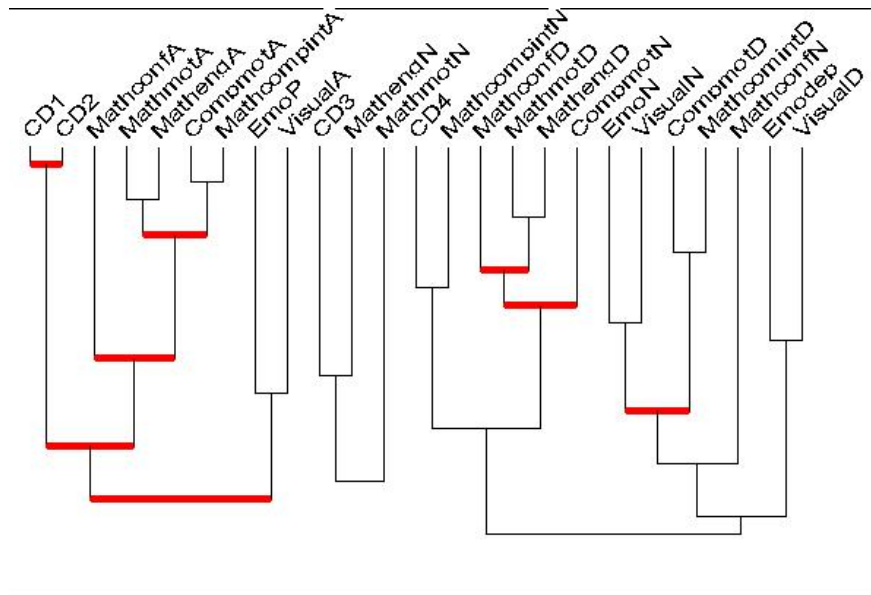

Figure 1. Similarity tree.

Group 1: this group was characterized by variables specifying a clear preference for visual reasoning and working on computers (EmoP VisualA) and positive attitudinal dimensions (MathconfA ((MathmotA MathengA) (CompmotA MathcompintA))). One of the most prominent elements was cognitive and problem visualization difficulties in the initial phase of problem solving.

Group 2: this group was associated with the variable describing instrumental genesis cognition and lack of both motivation for and commitment to mathematics. Not significant.

Group 3: this group includes variables relating to the global control of geometric tasks that affect discursive and instrumental processes in technology-assisted work, as well as neutral-to-negative attitudes towards mathematics and computers.

Figure 2 shows the implication analysis for implications with a reliability index of at least 85 % (color code: red, 99 %; blue, 95 %; green, 90 %; and black, 85 %).

This graph illustrates the causal relationships among emotions, cognitive processes expressed as cognitive difficulties and attitudes to technology. A preference for visual reasoning (VisualA) was found to be closely related to high motivation and positive emotions around computer use (CompmotA, EmoP). Student motivation to use computers (CompmotA) and a highly positive attitude toward mathematics-technology interaction (MathcompintA) implied a strong engagement with mathematics and to computer use (Matheng and Compeng).

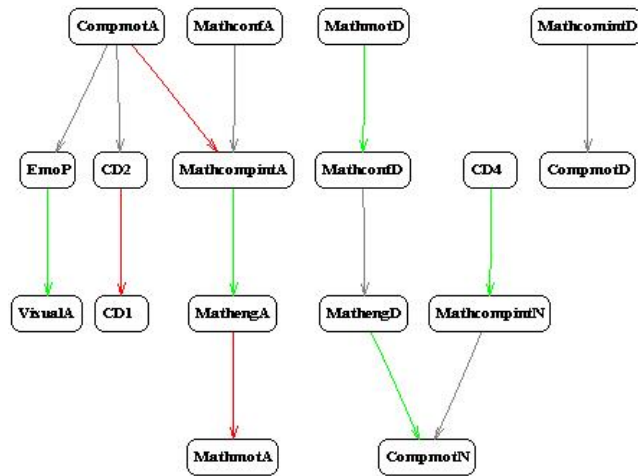

Figure 2. Implication graph.

The implication graph also showed which variables were associated with neutral or indifferent motivation toward computers and associated negative attitudes and cognitive blockage in geometric work with the switch from discursive to instrumental processes.

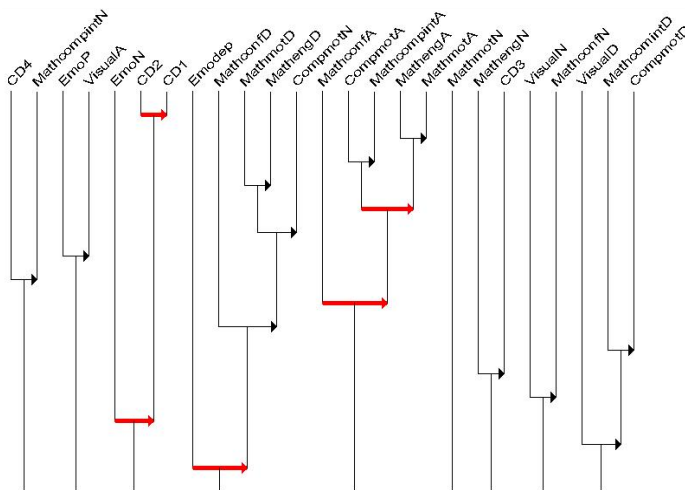

Figure 3. Hierarchy tree

Table 2. Rules of association.

<ol style="list-style-type: none"> 1. The absence of initial visualization led to difficulties in problem comprehension and interpretation. 2. A want of positive emotions toward computers was associated with difficulties in the initial visualization of the problem, its comprehension and the organization of the work involved in solving the problem. 3. Attitudes toward technology and mathematics are implied in computer work. Self-confidence in mathematics and motivation to use computers are what have the greatest impact on mathematics-computer interaction.

The hierarchy analysis tree, in turn, led to the deduction of certain rules of association, further to the implications detected (Figure 3 and Table 2).

In a nutshell, self-confidence in mathematics and motivation to use computers were the variables observed to have the heaviest impact on mathematics-technology interaction. The results also revealed the importance of visualization in understanding and solving problems.

Emotional regulation and technology-assisted learning

Another of the phenomena identified was students' feelings about their own emotions (meta-emotion). Many students provided details on their initial attitude, noting that they felt joy when they were able to solve a problem with the computer and let go of their apprehension. The reasons given were as follows. a) Working with a computer enhanced their pleasurable classroom experience and made mathematics more interesting, less abstract, by helping them to find a “*meaning*”. b) Computers favored learning and success in mathematics, strengthening visualization skills and the accuracy of calculations. c) Computers helped them establish connections between the algebraic and analytical dimensions. They noted that their apprehension receded when they were able to access algebraic and geometric windows that facilitated analytical and geometric comprehension. d) And a final category was associated with their goals as future teachers: “*I like it because it enhances my training and because as a teacher I’m going to have to know how to use it*” (A8-GA-E2).

A significant number claimed to have experienced anger in retrospect over their apprehension when trying to do the exercise with insufficient instrumental command, but added that their goal to be a teacher made them persist in finding the solution. This is illustrated fairly well in A19’s reply.

“The first obstacle is that computers don’t appeal to me particularly: I use them to study and to verify the results of exercises. When I don’t get the result I expect, I get nervous and frustrated, because I don’t know where to look to find the mistake. Nor do I have much patience when the computer crashes. Then I think that I’m wasting my time. I try to overcome these difficulties day by day, because computers are fantastic tools. They help you understand things better and to practice and they’ll be useful when I’m a teacher” (A19-GD-E2).

A33-GD-E2’s experience, in turn, reflects another aspect discussed above.

“On the one hand I feel more comfortable because it has a lot of tools that make mathematics easier, but on the other I’m on the defensive sometimes for lack of instrumental command. But I don’t give in and I use the computer itself to go on looking for ways to get around the problems, because I know they can be solved in several different ways” (A33-GD-E2).

In many of the cases studied, initial joy-calm helped students cope with their apprehension. This implies that “meta-emotion” can help them control negative emotions. A more in-depth review of this information identified connections among “meta-emotion” and cognitive processes and goals, and the values involved. The most prominent connections identified in the group were visualization and processes associated with future goals.

DISCUSSION AND CONCLUSIONS

The research sought to identify phenomena and the dynamic relationship between cognition and affect in a computing environment. Several emotional phenomena

associated with technology-assisted learning were categorised: a) an initially positive attitude toward computer-aided mathematics learning and a preference for visual reasoning; b) instrumental genesis associated with social and contextual dimensions of emotion and cognition; and c) the effect of meta-emotion on task performance and the development of visual processes.

The data shows trends in the group with respect to the dynamic between affective traits and cognitive difficulties in visualization and provides information allowing individual patterns to be identified. These emotional patterns are the result of individual differences (e.g., preferred goals and motives, visual and computers skills) and sociocultural processes (e.g., cultural values and beliefs about Secondary School education). Emotions can develop along a variety of pathways.

The methodological analysis using data mining has allowed exploration of structural relationships between affect and cognition and their possible causalities and directions (see implication graph and hierarchy tree). In the group, self-confidence in mathematics and motivation to use computers are what appear to have the greatest impact in mathematics computing. Contrary to the evidence reported in earlier studies (Galbraith & Haines, 2000), mathematics-computer interaction is not determined by these two dimensions separately: the relationship is more complex. While individuals' positive belief systems concerning visualization constitute a core value in mathematics-computer interaction, this does not confirm the findings of prior studies on preferences for visualization (e.g., Eisenberg, 1994). Rather, different emotions are associated with such beliefs. This emotional plurality and the individual and social elements in visualization-related instrumental genesis were identified by analysis of instrument use from an instrumental and cognitive approach, focusing on instrumentalization and instrumentation processes.

Another important aspect relates to the contextual nature of emotions, investigated through the teaching experiments for example the "Bell". These show how evaluations and priorities change during the development of the task and how the use of software becomes problematic. The goals, attitudes and beliefs in the performance of task not only have strong roots in mathematics but also in beliefs about the Secondary curriculum to be taught. Therefore another aspect to highlight is the ability of some students to switch to discursive genesis when experiencing blockage due to unsuccessful software exploration. In this case, as we showed in section 3.2., in the geometric work developed by the participants the variables relating to discursive and instrumental processes in technology-assisted work are linked to neutral-to-negative attitudes towards mathematics and computers. As a rule, teacher trainer assistance is needed to help students surmount this mental block and orient them towards discursive genesis or provide hints about software potentialities. As this study forms part of a task development project, this point is crucial to underline with students aiming to become teachers. In this example, we used personal teachers' students of Spaces for Geometric Work to develop a good "appropriate" Spaces for Geometric Work in the classroom and to describe the mathematical knowledge necessary for teaching.

In summary, these results are relevant for future research for various reasons:

1. The tendency explained in the literature for positive variables to correlate positively seems to hold true also for relations between different affective variables, but this is only a tendency, it is not presented as stable. However, we can claim that cognition (visual, instrumental, and discursive skills) and emotion are closely related.
2. The appraisal processes involve cognitive processes (i.e., the processing of information in terms of existing mathematical knowledge structures), but it is important to note the appraisal is not simply a mathematical, instrumental or cognitive affair. Instead, in emotional appraisal, cognitive representations of events function in service of an individual's goals, motives, and concerns.
3. From a more systematic perspective, these exploratory results might provide an empirical basis for the formulation of a theoretical taxonomy of the internal structure of emotions in the context of technology-assisted mathematics learning. The participants reported on a range of affective, motivational, cognitive and instrumental elements that may be used to establish such a taxonomy in pedagogical technology knowledge.

REFERENCES

- Artigue, M. (2002). Learning mathematics in a CAS environment: The genesis of a reflection about instrumentation and the dialectics between technical and conceptual work, *International Journal of Computers for Mathematical Learning*, 7(3), 245–274.
- De Corte, E., Depaepe, F., Op 't Eynde, P., & Verschaffel, L. (2011). Students' self-regulation of emotions in mathematics: An analysis of meta-emotional knowledge and skills. *ZDM*, 43, 483-495.
- DeBellis, V. A., & Goldin, G. A. (2006). Affect and meta-affect in mathematical problem solving: A representational perspective, *Educational Studies in Mathematics*, 63(2), 131-147.
- Eisenberg, T. (1994). On understanding the reluctance to visualize. *Zentralblatt für Didaktik der Mathematik*, 26, 109–113.
- Galbraith, P., & Haines, C. (2000). *Mathematics-computing Attitudes Scales*. Monographs in Continuing Education. City University London.
- Goldin, G. (2002). Affect, Meta-Affect, and Mathematical Belief Structures. In G. Leder, R. Pehkonen, & G. Törner (Eds), *Beliefs: A Hidden Variable in Mathematics Education?* (pp. 59-73) Dordrecht: Kluwer Academic Publishers
- Gómez-Chacón, I. M^a (2000a). *Matemática emocional. Los afectos en el aprendizaje matemático*. Madrid: Narcea. (Published in Portuguese by the publisher ARTMED-Editora in 2003 *Matemática emocional. Os afectos na aprendizagem matemática*)

- Gómez-Chacón, I. M^a (2000b). Affective influences in the knowledge of mathematics, *Educational Studies in Mathematics*, 43, 149-168.
- Gómez-Chacón, I. M^a (2011). Mathematics attitudes in computerized environments. A proposal using GeoGebra. In L. Bu & R. Schoen (eds.), *Model-Centered Learning: Pathways to Mathematical Understanding Using GeoGebra*, (pp. 147-170). Sense Publishers.
- Gómez-Chacón, I. M^a (2012). Affective pathways and interactive visualization in the context of technological and professional mathematical knowledge. *Nordic Studies in Mathematics Education*, 17(3-4), 57–74.
- Gómez-Chacón, I. M^a (print appear in 2014). Meta-emotion and Mathematical modeling processes in computerized environments, In B. Pepin, & B. Rösken-Winter (Eds.) *From beliefs and affect to dynamic systems: (exploring) a mosaic of relationships and interactions*. Springer (red series).
- Gómez-Chacón, I. M^a, & Kuzniak, A. (2013). A. Spaces for Geometric Work: Figural, instrumental and discursive geneses of reasoning in a technological environment. *International Journal of Science and Mathematics Education*, Volume 12, Number 1. DOI: 10.1007/s10763-013-9462-4.
- Gras, R., Peter, P., Briand, H., & Philippé, J. (1997). Implicative Statistical Analysis, In Hayashi, N. Ohsumi, N. Yajima, Y. Tanaka, H. Bock & Y. Baba (Eds.), *Proceedings of the 5th Conference of the International Federation of Classification Societies* (Vol. 2, pp. 412-419). New York: Springer-Verlag.
- Hannula, M.S. (2002). Attitude towards mathematics: Emotions, expectations and values. *Educational Studies in Mathematics* 49(1), 25–46.
- Leder, G.C., Pehkonen, E., & Torner, G. (eds.) (2002). *Beliefs: A Hidden Variable in Mathematics Education?* Dordrecht: Kluwer.
- Schlöglmann, W. (2002). Affect and mathematics learning, In A.D. Cockburn, & E. Nardi (eds.), *Proceedings of the 26th PME*, (Vol. 3, pp. 185–192.). Norwich, UK.

AN EXPLORATORY STUDY ON USING THE THINK-PAIR-SHARE COOPERATIVE LEARNING STRATEGY FOR STUDENTS TO SOLVE MATHEMATICS PROBLEMS IN A HONG KONG PRIMARY SCHOOL

Andrew P. Kwok, Alexandria Lau

Diocesan Boys' School Primary Division, Hong Kong

kwokandrewphilip@gmail.com

To develop primary students' skills of thinking and promote cooperative learning, the strategy of "Think-Pair-Share", suggested by Lyman (1981), was adopted in this exploratory study to enhance the learning effectiveness in solving monthly challenging problems in mathematics. Four classes in Grade 3, 4 and 6 were selected to participate in this study. Students first thought and worked independently about the monthly challenging problems and wrote down their thoughts; then they paired up to talk about their answers and decided the answer that they thought was the best; finally they shared their decisions with the whole class. Accuracy of each challenge problem was checked before and after the process of Think-Pair-Share. Class observation, questionnaire and group interview were also employed to investigate students' learning processes and identify the factors that impact on the learning effectiveness of applying this strategy. Data analysis suggested that students benefited greatly from this strategy of "Think-Pair-Share", which provided them the opportunities and space of both independent learning and peer learning. Students were more actively involved and motivated in the process of problem solving. The cooperative learning promoted by this strategy helped to lower the anxiety of students in solving the difficult problems, especially of those students with low level of achievement in mathematics. This study intends to obtain insights into understanding and developing students' learning experiences of using this strategy of "Think-Pair-Share" in a primary school in Hong Kong.

INTRODUCTION

This exploratory present study was carried out by teachers at the Diocesan Boys' School Primary Division in Hong Kong in 2012. They applied the Think-Pair-Share cooperative learning strategy to mathematics problem solving for Grade 3, Grade 4 and Grade 6 students. Previously, students were given the Monthly Challenge Questions and they would solve the mathematics problems individually. However, since participation was voluntary, low achieving students found the level of difficulty of the problems beyond their capability and gave up quickly. The high achieving students worked diligently to find the correct answers for all the problems and were awarded with bookmarks as prizes. The average accuracy rate was not satisfactory: 38% for Grade 3, 32% for Grade 4, and 36% for Grade 6.

Therefore, this study intends to explore whether the cooperative learning strategy might motivate students to be more actively involved in the process of problem solving, especially for those low achieving students.

LITERATURE REVIEW

‘Think-Pair-Share’ is a cooperative learning strategy that encourages students to work together to solve problems or answer questions on the assigned topic (Lyman, 1981). According to Lyman (1981), the procedure of ‘Think-Pair-Share’ includes the following steps:

1. Think: When dealing with a question, students are given a short period of time to think individually.
2. Pair: Students are to pair up with a classmate to discuss their thinking and jot down notes of their final conclusion.
3. Share: Students present and share their decision with the rest of the class.

Although it is a simple and practical technique, it can yield observable and significant enhancement of student learning outcomes (Davidson, 1990; Gregory & Kuzmich, 2006). A similar study to the present one was carried out in Nu Neng Primary School in Singapore in 2011. The teachers applied the ‘Think-Pair-Share’ cooperative learning strategy in mathematics classes. They concluded that the problem-based learning setting was a promising pedagogic approach that was able to promote positive attitudes (e.g. interest, perseverance and self-confidence) in students’ learning mathematics.

In addition, Oxford (1990) suggested that students could adopt affective and social strategies to help them learn more effectively, such as lowering anxiety, encouraging oneself, and cooperating with others. ‘Think-Pair-Share’ can also work as an affective and social strategy as it not only provides time and space for students to work individually on the mathematics problems but also opportunities for them to work together to clarify the questions that they have and identify the best solution, which can motivate students in mathematics learning, lower low achieving students’ anxiety and enhance their mathematics problem solving skills.

RESEARCH DESIGN

In an attempt to cultivate the students’ interest in solving mathematics problems, the Mathematics Department has been introducing the Monthly Challenging Questions to all students. Students will be given 3 problem-based questions, and hand in their answer sheets when finished. A bookmark will be awarded to those who got all 3 answers correctly. Since the participation is on a voluntary basis, about 70% of students participated in the activity. In addition, the accuracy rates vary between paralleled classes. Therefore, to encourage all students to be involved in this activity and promote peer learning, the ‘Think-Pair-Share’ strategy suggested by Lyman (1981) was adopted to address to following two research questions:

1. To what extent does Think-Pair-Share cooperative learning strategy impact on students' learning outcomes in Monthly Challenging Questions?

2. How can low achieving students develop their affective and social strategies in the process of Think-Pair-Share?

Participants were selected according to students' previous performance in this activity (Table 1).

Table 1. The Accuracy percentages of each grade and 4 participating classes.

Grade 3	Grade 4	Grade 6
3J/ 3S	4M	6D
38%	32%	36%
23%	24%	10%

As indicated in Table 1, the accuracy rates of the selected classes, i.e. 3J, 3S, 4M and 6D, were much lower than the average accuracy rates in their own grade, respectively 23% of 38%, 24% of 32%, and 10% of 36%.

The study lasted from February to June 2012. Classroom learning processes and outcomes of students in the experimental group were observed and recorded. Monthly Challenge Questions scores between the experimental group and the control group were compared to monitor learning effectiveness. About 110 students in the experimental group completed questionnaire survey (Appendix 1) and 12 pairs of students were given group interviews. The questions were grouped to investigate factors of motivation, academic learning time, self-confidence, interaction, and feedback on learning. The ratings and responses were analyzed to find out possible underlying reasons and processes that contributed to the changes.

FINDINGS AND DISCUSSION

The analysis of collected data indicated that there has been significant improvement in students' learning attitudes and learning outcomes with Think-Pair-Share cooperative learning. The experimental groups had higher percentages of getting all correct in mathematics problem solving in Monthly Challenge Questions (Table 2).

Table 2. Accuracy Rates.

All correct	February	March	April
3J, 3S	59.3%	62.5%	30.0%
Other Grade 3 classes	(29.8%)	(51.9%)	(15.4%)
4M	46.7%	60.7%	56.7%
Other Grade 4 classes	(37.9%)	(24.0%)	(12.0%)
6D	96.3%	77.8%	88.9%
Other Grade 6 classes	(52.9%)	(64.0%)	(57.0%)

Table 2 showed that all participating classes consistently achieved higher accuracy rates than the average rates of their own grades. It seemed that using the strategy of ‘Think-Pair-Share’ could help students to improve their performance in the monthly challenging problems.

According to students’ responses to survey questions, the strategy made the activity more interesting to students and students were more motivated to learn, with mean scores 3.3 for Item 3 and 11 (Table 3). It also succeeded in promoting students’ cooperative learning and positive attitudes in the process of ‘think-Pair-Share’, as the mean scores reached 3.6 for Item 12, and 3.5 for Item 17 (Table 3). Students found that the strategy got them involved in the learning process and benefited from it, with mean scores 3.4 for Item 13 and 15.

Table 3. Motivation.

	Question	3J	3S	4M	6D	Mean score
3	I enjoy doing Monthly Challenging Questions more than before.	92	83	99	84	3.3
11	This Think-Pair-Share approach makes solving the Monthly Challenging Questions more interesting and challenging.	84	82	110	88	3.3
12	I enjoyed working with my friends to solve the Monthly Challenging Questions.	91	90	112	97	3.6
13	I like the new grouping and Think-Share-Pair approach as I learn better.	93	82	108	90	3.4
15	The challenge of solving Monthly Challenging Questions task kept me going and thinking.	86	90	104	92	3.4
17	Solving problems with a group of friends made the Monthly Challenging Questions more interesting.	87	88	108	98	3.5

Such cooperation helped students to increase self-confidence. For example, the mean score was up to 3.6 for Item 2, 3.5 for Item 8 and 3.3 for Item 18 (Table 4).

Table 4. Self-confidence.

	Question	3J	3S	4M	6D	Mean score
2	I have confidence that I can achieve better results by doing the Monthly Challenging through TPS.	89	86	105	93	3.6
8	I found out my mistakes during the discussion session with my group members and I am sure I can correct it.	83	91	12	96	3.5
18	I feel more confident at solving difficult mathematics problems now than before.	86	84	110	79	3.3

Furthermore, Table 5 indicated that it seemed that the strategy of ‘Think-Pair-Share’ could lower students’ anxiety of sharing their own thoughts (3.6 for Item 1) and speaking in front of the class (3.7 for Item 2). This could possibly due to the fact that the process helped students become more confident with their answers to the problems after discussing with peers. They enjoyed learning together with their peers. For example, mean scores were 3.5 and 3.4 out of 4 for Item 4 and 6 (Table 5).

Table 5. Lowering anxiety.

	Question	3J	3S	4M	6D	Mean score
19	I was not afraid of sharing my answers to my partner when doing the Monthly Challenging Questions.	91	90	114	99	3.6
20	I was not afraid of sharing my answers in front of class.	96	84	106	86	3.7
4	I like sharing my ideas with my partner.	92	86	109	98	3.5
6	I enjoy hearing my classmates’ presentations which are different from mine.	93	85	105	98	3.5

Analysis of the transcripts of students’ responses revealed that they enjoyed having the opportunity to interact and collaborate with their partners. The discussions made them spend more time on thinking and understanding the problem. The feedback helped them find out and correct their mistakes. The mutual support and cooperation fostered team spirit and group dynamics to tackle the problems.

“We can discuss the questions so it is more fun.”

“The sharing part is most helpful. It helps me understand.”

“You can team up with the other guy and give each other ideas if you don’t understand.”

“If I am wrong, he will tell me where and why I did wrong.”

“The more capable student should be paired with the less able one. If the weaker one does not know, the stronger one can help.”

(Extracts from student interviews)

In addition, the learning process through the Think-Pair-Share cooperative learning strategy was thought to be a progressive and linear process, as illustrated by the following diagram suggested by Lyman (1981):

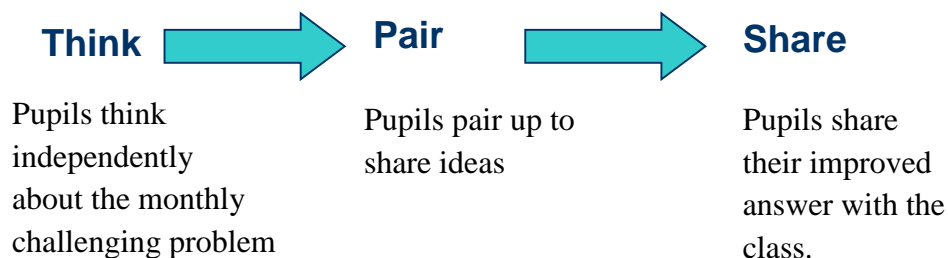

Figure 1. Lyman’s Model.

This model depicted a definite start-point and end-point. In this study, a refined model was suggested and conducted with the three processes interacting continuously in a cyclical process, which could yield even higher learning effectiveness as illustrated by the following diagram.

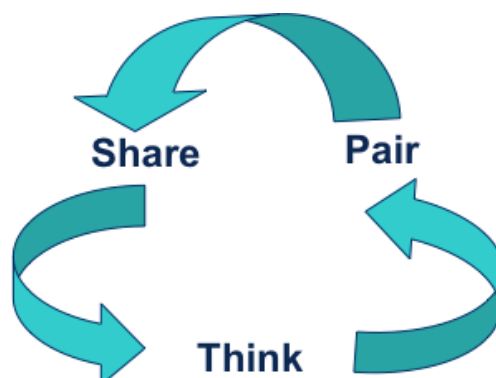

Figure 2. Revised Model.

The three elements in the cycle could work continuously in a non-stop manner and interact in the whole process of 'Think-Pair-Share'. It increased social interactions and affect as well as enhanced cognition with the cooperative learning strategy. The positive attributes helped students solve mathematics problems more effectively.

CONCLUSION

To conclude, this exploratory study examined the use of 'Think-Pair-Share' strategy in the activity of monthly challenging questions. It was found that students worked collaboratively in understanding the questions, sharing their ideas and formulating a solution to solve the mathematics problems more effectively. They had more positive affect and enhanced cognitive thinking, and as a consequence, better learning outcomes and success rates. The improvements in their success of solving mathematics problems in Monthly Challenge Questions were explained by increased interactions, corrective feedback, heightened motivation, and enhanced self-confidence. The strategy of 'Think-Pair-Share' fostered effective classroom learning environments with better affect among student groups. There were increased interactions and feedback, the emotional support and group dynamics between the learning partners. The groups had higher intrinsic and achievement motivation to attain the goal and present the solution to the class. The strategy also enhanced the cognitive learning process. The learners had more academic learning time spent in discussion, enhanced their thinking process from peer's corrective feedback and self-reflection for deeper and more thorough understanding.

Since this study was only small-scaled and lasted only five months, it was limited by time and resource constraints. Nevertheless, it sheds lights on how cooperative learning can be adapted to be good teaching practice for mathematics problem solving with enhanced learning effectiveness. It will be interesting for future large-scale and long-term studies to investigate factors in pedagogy, students grouping, classroom organization and school settings that can help students learning in mathematics more collaboratively and effectively.

REFERENCES

- Davidson, N., & Worsham, T. (1992). *Enhancing thinking through cooperative learning*. New York: Teachers' College Press.
- Gregory, G. H., & Kuzmich, L. (2006). *Teacher teams that get results: 61 strategies for sustaining and renewing professional learning communities*. Thousand Oaks, CA: Corwin Press.
- Lyman, F T. (1981). The responsive classroom discussion: The inclusion of all students. In A. Anderson (Ed.), *Mainstreaming Digest* (pp. 109-113). College Park: University of Maryland Press.
- Oxford, R.L. (1990). *Language Learning Strategies*. New York: Newbury House.

Appendix 1. Questionnaire.

	Questions
1	The accuracy of doing the questions is raised.
2	My participation on doing the Monthly Challenging Questions is bigger.
3	I enjoy doing Monthly Challenging Questions more than before.
4	I like sharing my ideas with my partner.
5	I hope that I can do the Monthly Challenging Questions under this circumstance.
6	I enjoy hearing my classmates' presentations which are different from mine.
7	I hope that our regular Math lessons can be conducted in this approach.
8	I found out my mistakes during the discussion session with my group members.
9	We found out our mistakes during the sharing session with our class in front of the class.
10	I would prefer using the approach of Think-Pair-Share in solving word problems than doing by myself.
11	This Think-Pair-Share approach makes solving the Monthly Challenging Questions more interesting and challenging.
12	I enjoyed working with my friends to solve the Monthly Challenging Questions.
13	I like the new grouping and Think-Share-Pair approach as I learn better.
14	The problems were hard but I did not give up because my partner supports me and help me understand my mistakes.
15	The challenge of solving Monthly Challenging Questions. task kept me going and thinking.
16	I was focused on finding the solutions to the Monthly Challenging Questions.
17	Solving problems with a group of friends made the Monthly Challenging Questions more interesting.
18	I feel more confident at solving difficult mathematics problems now than before.
19	I was not afraid of working in groups to solve Monthly Challenging Questions.
20	I had greater understanding in Monthly Challenging Questions through the TPS approach because of help from friends.

A MATHEMATICAL CONGRESS: A WINDOW TO AFFECT IN PROBLEM SOLVING

Teresa Pimentel*, Isabel Vale**

* Secondary School of Santa Maria Maior, Portugal, ** School of Education of the Polytechnic Institute of Viana do Castelo, Portugal

terpimentel@gmail.com, isabel.vale@ese.ipvc.pt

In this paper we focus at an on-going project taking place at a secondary school open to the whole community, the mathematical congress, that aims to develop students' interest about mathematics and to improve their problem solving and communication skills. The results suggest that most students, and not only the high achieving ones, are able to follow a line of reasoning, develop self-confidence in their mathematical communication capacity and choose their participation in the mathematical congress as one of the most interesting and important things in which they have been involved at school.

INTRODUCTION

Mathematics is traditionally a discipline with high failure rates in Portugal in national examinations and in international studies about which many students can't manage to understand any beauty or even usefulness. In the last years things are changing, which is guaranteed by the results of PISA 2009 and PISA 2012 (e.g. OECD, 2010; 2013). Such positive changes must be supported not to move backwards. Thus, it is fundamental to focus on developing students' higher order skills such as formulating and solving problems, mathematical reasoning and communication. On the other hand, very often students can't make connections among several topics and make use of different tools to approach the same problem in the classroom, since curriculum features and extension lead teachers to avoid this type of exploration. To overcome these shortcomings, a project named *Mathematical Congress* was designed in a secondary school, open to all students (10th to 12th graders). It aims, among other features, to create a space for informal meeting on the learning of mathematics, to promote students' mathematical discourse (Kieran, 2001), to develop the capacities of problem solving and problem posing (Silver, 1997), to increase knowledge about mathematical topics and processes, to promote democratic rules of attentive listening and expression of ideas, and to value and appreciate the students' work. In its principles it is set that this initiative, more than directed to students, is constructed by students.

The mathematical congress takes place three or four times a year as an extra-curricular activity and consists mainly of oral presentations made by students around previously known problems, but allows further intervention. Once a year, students of neighboring basic schools are invited to participate. The format has been modified along time to adjust to students liking and expectations. Every congress has a theme. Some of the former

themes were Optimization, The golden ratio, The geometry of the triangle, Route to infinity, Quadrilaterals, Mathematics of the planet Earth, etc.

The project followed the question: What event format, what tasks and what teachers' attitudes are, in this context, promoters of motivation for the students participation and foster students' mathematical problem solving and communication skills?

The aspects related with this question are embodied with affect, in its cognitive and non-cognitive elements. In this paper we will present the features of the mathematical congress, describing some episodes that illustrate the mode as it follows, as well as the opinions of some participants and teachers involved, and the way they intersect with some components of affect, such as cognition, emotion and motivation. At the end we draw some conclusions based upon the gathered data.

AFFECT IN PROBLEM SOLVING AND COMMUNICATION BEYOND THE CLASSROOM

Challenges are not a new field in mathematics. The construction and organization of mathematical knowledge and the explanation of new concepts are triggered by the discovery of patterns and consequent emergence of new challenges to talent (Protasov et al., 2009). However, the process of acquiring mathematical knowledge such way takes place in many forms beyond the classroom (Kenderov et al., 2009). These authors argue that these environments, normally competition-like activities, but also clubs, journals, lectures, projects and so on, can serve to motivate and challenge mainly the students with higher abilities and talents, that otherwise should be ignored and would disappear. They also consider that these activities can give a chance to enjoy mathematics to students that, due to several factors, could never feel its beauty. There is yet a fundamental distinction between inclusive, open and exclusive competitions or other mathematical events. For the intents of this paper, we adopt the concept of inclusive event, in which a large number of students of all standards participate. (Kenderov et al., 2009) highlight the role of competition-like events in elevating standards, fostering perseverance, reasoning, communication and autonomy, motivating students to work, providing opportunities to socialize, learning to manage stress, and feeling joy, pride and recognition. For some students, the simple fact of participation is a great success.

A challenge may be defined as “a question posed deliberately to entice its recipient to attempt a resolution, while at the same time stretching their understanding and knowledge of some topic” (Barbeau, 2006, p.5). Even considering the proximity of the constructs “problem” and “challenge” we can focus in a difference: Powell, Borge, Fioriti, Kondratieva, Koublanova and Sukthankar (2009) claim that a mathematical problem is a challenging one only if learners build what are for them new mathematical ideas and go beyond their previous knowledge. Giving challenges to students at every level of development can avoid negative emotions (Hannula, 2004) but it is also important to enhance problem solving capacity and develop creativity (Protasov et al., 2009; Silver, 1997; Vale & Pimentel, 2011). Powell et al. (2009) even claim that

making mathematics more inclusive requires shifting from a common sense among teachers that higher-order thinking through challenging tasks is not appropriate for low achieving students.

Communication is an essential process for mathematics learning, mainly if focused on cognitively challenging mathematical tasks - namely, those tasks that promote thinking, reasoning, and problem solving, as a primary mechanism for promoting conceptual understanding of mathematics. Through communication, students reflect upon, clarify and expand their ideas and understanding of mathematical relationships and mathematical arguments. (e.g. Smith & Stein, 2011; NCTM, 2000). But talking and writing about mathematics is a hard task and doesn't come naturally. Communicating about mathematical ideas is not always easy; teachers need to help students learn how to do so. This is yet more important if they have to communicate beyond classroom, with a high degree of effectiveness for an audience, such as in the mathematical congress. They need to express their mathematical ideas in a way that motivate and grasp the understanding of their peers and teachers. So they must organize or re-organize their ideas and refine or revise their strategies, firstly for themselves and after to others, precisely and coherently, using oral, visual forms or others resources (e.g. ICT, concrete materials) before launching to a group. As they are free how to do that, they can use their creativity.

Some of the above ideas address the field of affect. Most research in this field in mathematics education uses the concepts of beliefs, attitudes, emotions and values (Goldin, 2002). Hannula (2004) conceptualizes affect as subjective experience, considering that affect involves cognitive aspects in addition to emotion, while emotion is limited to non-cognitive elements. This author claims that emotion, cognition and motivation are the three basic concepts used to define other concepts in affect, and forming an individual's self-regulative system. In this system, emotion and cognition are representational systems, and they require motivation as a third, energizing system. In mathematical thinking, this third aspect creates goals in a situation, such us to solve a task, to master a topic, or to impress someone. Emotions are an evaluation of the subjective progress towards goals and obstacles on the way. In this process, cognition interprets the situation, explores possible actions, estimates expected consequences, and controls actions. Identifying the most common positive and negative academic emotions (e.g. enjoyment, pride, anger, boredom, anxiety, hopelessness) the author aims to determine how to reach the former and avoid the latter, since negative affects can seriously influence mathematical outcomes. The solution will set in the balance of protecting students from negative experiences and giving them challenge to avoid boredom. In what concerns motivation, Hannula (2004) argues that, instead of just controlling students' needs, teachers should learn to use them. Collaborative activities provide opportunities for social needs to be met. For example, the need of autonomy is met when they are working on investigations or open problems. The need of entertainment can be reached with the help of games to practise tedious routines. A willingly participation is possible when students feel that their needs are met in the

mathematics work. Evans (2006), focusing on three different sociocultural approach studies, socio-constructivism, cultural-historical activity theory, and a discursive practice approach, concludes that all view mathematical thinking as embodied with emotion – in contrast with the common sense view of mathematics as “cold”, not emotive. These accounts don’t see emotions towards mathematics as negative or debilitating, as was the case in earlier research programmes, but often show them as positive/facilitating. Further, all three approaches stress the importance of the social, the context of learning, being this context either the type of course or school, the person’s positioning within the discursive practices, or the activity within a community, with its collective “motives”, and located culturally and historically.

However, we must be particularly careful in the choice of the proposed challenges; the goal must not exceed the abilities and characteristics of the group. In a good challenge the person has the necessary mathematical skills, but needs to use them in a nonstandard or innovative way. It often involves explanation, questioning and conjecturing, multiple approaches and evaluation of solutions (Barbeau, 2006).

METHODOLOGY

Trusting the potential that events like the Mathematical Congress have in the integral development of students, either cognitive or affective, we adopted for this study, focused in a secondary school, a qualitative and interpretative approach based in observation and questionnaires in order to answer the question of the study. This was complemented with interviews to twelve participants to gather more specific and personal opinion. We used a selection based on the following criteria: gender; grade level; mathematics attainment level; type of participation – with and without oral presentation; present attendance of the school. This last item is justified because we considered the usefulness of gathering opinion from youngsters that, having participated in mathematical congresses, have already completed the secondary level and so are not attending this school anymore.

As this project has been ongoing for four years, the format of the congress has been modified based in those opinions and in the ones of the teachers involved, trying to obtain a more active participation and interest of all the audience.

At the end of every mathematical congress all participants fill a questionnaire where they give their opinion about presentations of the different groups, involvement of the participants, mathematics learning, opportunities to live together and organization.

The congress team includes all the mathematics teachers of the school, which are involved in this project and observe their pupils’ behaviour towards this initiative, namely the role and attitude of the students, either in the congress or before and after it.

THE CONTEXT OF THE CONGRESS

About two weeks before the event, the teacher coordinator of the project launches the theme and usually two problems which are exposed in the mathematics panel (situated

in a visible place) and published by the mathematics teachers in their disciplines at moodle. The teachers must also inform their students in the classroom, giving them some time to make acquaintance with the proposals. The students are then encouraged to work in the problems alone or rather in small groups. Some days later, students that want to present their resolutions in the congress must announce it. The sequencing is then set by the responsible teacher facing the various proposals submitted by the students, according to the model of Smith and Stein (2011), aiming a progressive development of strong mathematical ideas and connections within topics and according to the use of different mathematical tools.

The Congress time is about 75 minutes and occurs on Thursday afternoon, in which there are no lessons at school to allow collaborative work of teachers and/or activities beyond the classroom. Although in the first sessions, four years ago, there were few students, nowadays we have always more than a hundred students attending the congress.

In the beginning of the project, the organizer was always the coordinator teacher, that conducted all the works. Yet, the dynamics had been progressively passed to students responsibility. Before every congress, a different group of 6-8 students is invited to dynamize the session and, with that purpose, they join with the coordinator teacher to organize and discuss the details. Gradually, also some students were encouraged to be responsible for technical support as computers, projection, sound (including music in the transitions) and light. This feature raises enthusiasm and participation of more students who initially had no desire to participate but like this type of tasks.

The tasks of this group of dynamizers are: (a) to present the session, explaining a bit its theme; (b) to present the colleagues which are making their oral presentation; (c) to purpose other challenging tasks that can be solved in a few time, during the session, to raise interaction among the participants, since the majority of the students is not going to make any oral pre-organized presentation; and (d) to tell some mathematical jokes to ease between presentations.

We synthesize in Table 1 the differences that had been occurring in the congress format along time, due to students' opinions and teachers' findings, based on previous experience.

Table 1. Differences between previous and latter congress format.

Previous events	Latter events
Moderation by the coordinator teacher.	Moderation by groups of students.
Only oral presentations previously prepared.	More challenges during the congress. Mathematical jokes and quizzes to ease.
No more intervention.	Encouraging students to share some mathematical findings or search.
Basic technical use.	Groups of students for technical support as computers, projection, sound (including music in the transitions) and light.

In the last congress of the school year, when some students of neighbour schools are invited to participate, we add some more items to the program, such as a dramatization about a related mathematical subject. For example, once when the congress was held in March, 14, we celebrated Pi Day with a dramatization and a parade with the twenty first digits of pi. Another time the dramatization focused in the story Flatland. Sometimes we project a small movie about a mathematical theme. Although it is not the case of the reported congress, there are some where a group of students share a search about any mathematical topic or present a work in the context of the mathematics lessons.

SOME RESULTS

We will relate here the content and dynamics of part of a mathematical congress held in last school year, as well as the data gathered from the questionnaires, teachers' opinions and interviews. The following description reflects a typical congress.

The theme of this congress was *Quadrilaterals*. The following two problems were proposed in advance.



Draw a square with side a and then another square, whose side is greater than a , in such a way that one of its vertices is in the centre of the smaller square, and freely rotating around it.
Study the variation of the intersection polygon area.

Figure 1. Squares problem.

Four straws, two of length a and two of length b , are joined to form a kite, as shown in figure.

We can move the straws changing the internal angles of the quadrilateral.
Under what circumstances do we obtain the maximum area?



Figure 2. Kite problem.

With respect to the first problem, two groups of students made an oral presentation. The coordinator teacher sequenced them purposefully to show the evolution of mathematical ideas. The first was an exploratory approach, with Geogebra, made by 10th graders. They discovered, recurring to the dynamic characteristics of the software, that the area is always the same, but didn't feel the need to prove it. In the second presentation, two 11th graders used coloured cardboards to make the problem more visible, but made an analytic approach proving with support of triangle congruence that the area must be always the same, since the triangle missing in one side of the quadrilateral to complete the square is on the other side. At the end of these presentations, the coordinator profited to call attention to the importance of proof, which gives us the warranty of certainty of our intuitions or findings obtained, for

example, with the help of dynamic geometry systems, and, moreover, allows us to explain why things work.

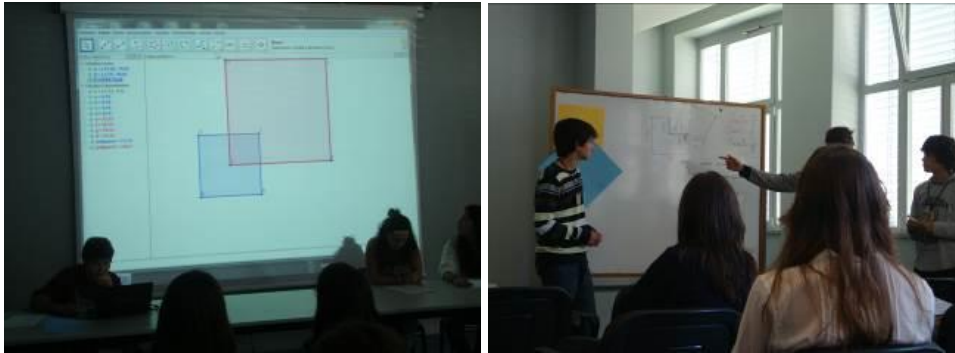

Figure 3. Presentations of the squares problem.

At this moment two students called the attention of their colleagues with some mathematical jokes and an extra problem – Figure 4.



Figure 4. Jokes and quizzes.

Concerning the second problem, it was first presented by two students of 10th year that treated a particular case, considering the kite as a rhombus, and then presented by a 12th grader that attacked it with trigonometry – Figure 5. Curiously, none of the presentations used manipulative material.

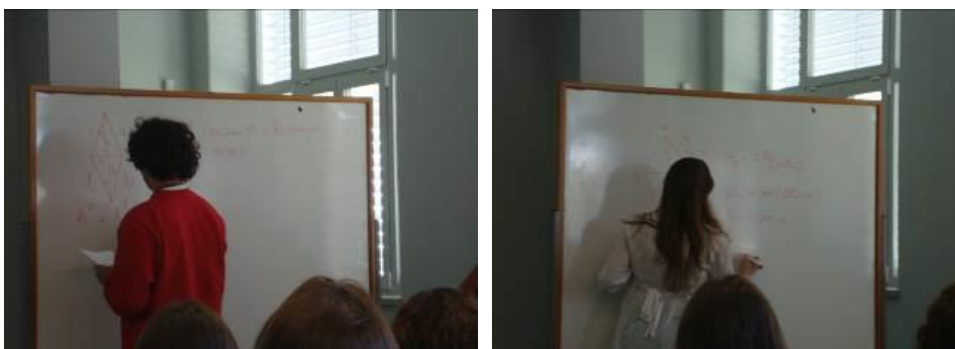

Figure 5. Presentations of the kite problem.

Then, another student who was organizing the session performed a number called *Seeing without seeing*, in which she led her colleagues to imagine that a paper square joined them in the beach. They must imagine picking the square and then,

folding it, marking the midpoint of one side and link it to an opposite vertex. The questions were, then: What are the figures obtained? What is the ratio of their areas?

At the end of the congress, a questionnaire using a Likert scale-type is filled by all participants. There, they must assign a level from 1 to 5 (bad to very good) to the following features: presentations of the different groups, involvement of the participants, mathematical learning, opportunity of living together, organization and moderation, and a global evaluation - Figure 6.

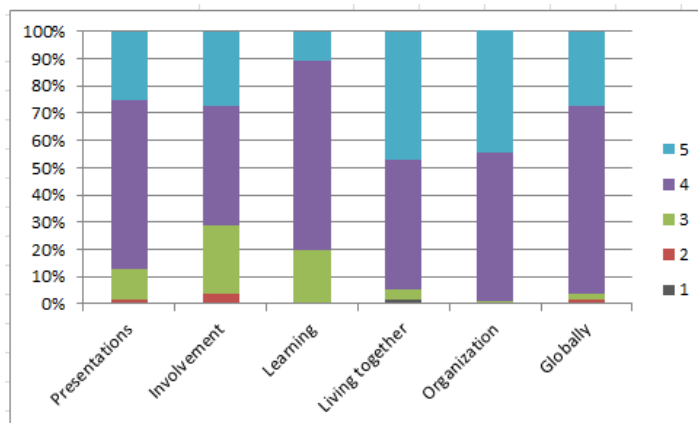

Figure 6. Evaluation of the congress.

Initially the questionnaire included more questions, but the teachers' team considered that it must be simplified, so in the moment of this session there were only these six questions. As we can see, the majority of the results are situated at levels 4-5, good or very good. The item with lowest assessment concerns the involvement of the participants. This is due to some difficulty for students to feel at ease to publicly contend their colleagues. At the end of the presentations some questions sometimes arise from the audience; but this is an aspect to improve. The second lowest assessment addresses the mathematical learning. Actually, from conversations with students we can infer that some students consider that mathematical learning only occurs in the classroom or at home doing exercises about the contents of the curriculum; mathematical learning is only knowledge that is going to be evaluated in written tests or examinations. We can also verify by the results that participants value a lot the organization and moderation made by their colleagues. Although this evaluation refers to this particular congress, the results of the other congresses don't stay far from these ones.

All the teachers come together at the end of congress to express and exchange opinions and comments on how it elapsed. They primarily discuss the quality of the presentations and interventions made and the attention and interest of the participants. They always comment the unexpected participation of turbulent, uninterested in classes and weak students. Their opinion is unanimous along years: this is a project that involves many students, who show an interest and willingness to participate that is, in many cases, beyond their own interest in classroom mathematics, and, sometimes, helps in this matter; the students usually care with the good quality of their

presentations, either in mathematical correctness or in manipulative or technical support; the students feel proud with their presentation performance, as *scientists* or as moderators. Of course this sharing doesn't restrict to the day of the event, as this is a project that evolves along the school year and it is necessary to give continuity to the actions developed.

The interviews that were made to twelve students were conducted by the congress coordinator teacher in the beginning of this school year and lasted approximately 15 minutes each. The script of the interview included the following questions: (a) What do you think about the mathematical congresses that have been held in the time of your stay in school, including the format changes that were made? (b) In your opinion, which was harder: to solve the problems or to present them in publicly? (c) Did you ask help to solve/present the problems? (d) Do you think your participation developed capacities? Which ones? Do you think that they will be useful in the present and/or in the future? (e) In what extent, in your opinion, the congress help to improve the learning of mathematics? (f) What is your feeling, in affective terms, in relation to the congress? What marks produced? What memories do you keep?

We will present now some results of those interviews, facing each of the above items.

Some students mention one of the principles of the mathematical congress, which is that it must be presented by students and for students. Some refer that the congress encourages them because it shows the fun and playful side of mathematics. They have the opportunity to play with mathematics. They also can contact with a wide variety of mathematical themes. Students mention some other features that they consider the congress allows: facing and solving challenges, discuss ideas and realize new approaches and perspectives of the same problem. Some students referred as positive the increasing affluence of people. All the students interviewed consider that the actual format is much more suitable, because it allows more active participation, more interaction between students and consequently more interest, and can motivate for learning. Some consider that it is good there to be new proposals during the congress, since even who didn't think in the former problems can participate. Some students find the jokes very useful to relax a little between presentations, and some of them said that there would be a time limit for presentations. They refer specifically to the oral presentations of the invited students, in the last congress of the year.

All the students find harder the oral presentation than the resolutions of the proposed problems, arguing that it is difficult to be able to pass on to others what they are thinking, so they must find a way to get it understandable, and also that it is hard to capture the attention of the public. All of them assert that they solved the problems by themselves or, mainly, in collaboration with their peers, but, sometimes, with the help of their teacher.

Some students refer reasoning as the most important capacity which is developed. In the words of a girl: "Problems are not common mathematics, as we learn in the

classroom, they are not subject matter; and so we feel inside us something... and we need to reason”.

But most claim that it is fundamental the development of communication skills that can be very useful in future public interventions, either in the university or in a job. A girl claims: “The need for presentation makes me less shy and helps me to deal with pressure”. These results are consistent with Kenderov et al. (2009), in particular when he says that this type of events provide opportunities to socialize and learn to manage stress.

Concerning learning, some students argue that an explanation given by a colleague can be more productive and comprehensible to them because he/she uses a closer language. They also refer the connections: “We can identify a wide variety of matters in just one problem, which is a way to link subjects”. Some mention their willingness of finding a solution or even different approaches to the same problem. These students perceive the tasks as challenges in the sense of Barbeau (2006), as a question for which students must attempt a resolution, while at the same time asks for their understanding and knowledge of some mathematical content. In the point of view of a boy who never made any oral presentation, it is good to listen to different modes of approaching the problems and it is a way for him to learn how to solve them. He says that he usually checks the problems panel to know the theme of the congress and sometimes he tries to solve the proposed problems in advance with his mates.

Relating to memories and affects, all students claim that they will always remember the congress, because beyond learning there is an intercourse among students and teachers, because of the sharing of ideas, and because it is a different way of facing and living mathematics. A girl said that she remembers mainly the nervousness about having to speak publicly. A boy, a 12th grader, told that his Portuguese teacher asked them, in the beginning of this school year, to make a composition about memories and projects at school and he mentioned the mathematical congress because it marked him: “It was one of the things that most impressed me here at school because it is a participation with the very school community, so I think I'll remember it the best way”. We transcribe the opinion of an ex-student of the school: “I remember the congresses I attended, with a huge number of students, that not only discussed the problems purposed, but also introduced new challenges and gladly spoke about mathematics to and with colleagues, proving that this is fun and, after all, appreciated by many”. And “I remember the congress auditorium filled with attentive and bright eyes, creative and varied presentations”.

In this description we can detect the energizing component of affect as advocated by Hannula (2004). In fact, the students show motivation when they engage in a task they are solving, call for their mathematical potential to master a topic, and when they want to impress an audience during their intervention in the congress.

CONCLUSION

Trying to answer the question of the study, we synthesize, based upon the results of the previous section, features of the event format, tasks and teachers' attitudes that revealed promoters of motivation for the students participation and may foster students' mathematical problem solving and communication skills. The teachers' role in disclosing the congress proposals as well as in encouraging their students' participation in the congress is fundamental. Yet, the teachers' intervention mainly happens before the congress. Although all the school mathematics teachers attend the congress, they rarely intervene to live place to students' intervention, since this is one of the principles, and highly valued by the students. Only the coordinator teacher acts sometimes as a moderator to make synthesis when it is necessary.

Regarding learning and communication skills, observation of the sessions by the teachers involved and some conversations with students after them may support the conclusion that most students that are only in the audience follow attentively the reasoning produced by their peers in oral presentations and are able to understand and reproduce it. Although many participants have a high achieving level in mathematics, there is a good percentage of medium and low achieving students that attend the congress and feel very comfortable with it, in consonance with Powell et al. (2009). A feature to improve is that most students don't feel at ease to question their colleagues since there are many participants of different grade levels and it is hard to confront a colleague in public.

In line with Barbeau (2006), and according to students' and teachers' evaluation, the tasks that are most suitable are the open ones, that allow many different approaches, but which are not too difficult. They also consider that the interventions must not be very lasting and that the proposals inside de congress, including new problems, quizzes and some entertainment moments around easier and faster challenges are welcome.

At the level of affects, the students feel well in the congress – and this is supported by the great free affluence in an afternoon free of classes. Being responsible to make a presentation in a mathematical congress, students feel proud of their capacities, either in mathematics or in communication skills. These results are according to Kenderov et al. (2009). Above all, they elect their participation as one of the most interesting in which they are involved at school. Besides, they consider that the congress leave a positive mark that they (will) recall after leaving school. They also argue that their intervention may prepare them to other challenges in their future school or professional life. We could detect in students, according to Hannula (2004), positive emotions, like enjoyment, pride and recognition. Students' motivation to participate may have begun with the use, by the congress organization, of their needs of challenge, understanding a topic, impressing an audience, autonomy and entertainment.

In sum, this initiative seems to have potential to foster students' motivation towards mathematics, to learn about different mathematical processes and approaches, sometimes to the same problem, to develop creative ways of thinking mathematically

in order to present different and original answers, and to build up communication skills. It is also a good contribution to improve and maintain a *spirit* of the school, joining many students in a common project and giving them willingness to share mathematical discoveries.

REFERENCES

- Barbeau, E. (2006). Chapter 0 - Introduction. In E. Barbeau & P. Taylor (Eds.), *Challenging Mathematics In and Beyond the Classroom – New ICMI Study Series 12* (pp. 1-10). Springer.
- Evans, J. (2006). Affect and emotion in mathematics thinking and learning. In J. Maasz & W. Schloeglmann (Eds.), *New Mathematics Education Research and Practice* (pp. 233–255). Sense Publishers.
- Goldin, G. A. (2002). Affect, meta-affect, and mathematical belief structures. In G. C. Leder, E. Pehkonen & G. Törner (Eds.), *Beliefs: A Hidden Variable in Mathematics Education* (pp. 59-72). Dordrecht, The Netherlands: Kluwer.
- Hannula, M. (2004). *Affect in mathematical thinking and learning*. Turku: Turun Yliopisto.
- Kenderov, P., Rejali, A., Bartolini Bussi, M., Pandelieva, V., Richter, K., Maschietto, M., Kadujevich, D., & Taylor, P. (2009). Challenges Beyond the Classroom—Sources and Organizational Issues. In E. Barbeau & P. Taylor (Eds.), *Challenging Mathematics In and Beyond the Classroom – New ICMI Study Series 12* (pp. 53-96). Springer.
- Kieran, C. (2001). The mathematical discourse of 13-year-old partnered problem solving and its relation to the mathematics that emerges. *Educational Studies in Mathematics*, 46, 187–228.
- National Council of Teachers of Mathematics (2000). *Principles and standards for school mathematics*. Reston, VA: NCTM.
- OECD (2013). *Pisa 2012 Results: Ready to Learn – Students Engagement, Drive and Self-Beliefs*. PISA, OECD Publishing.
- OECD (2010). *Pisa 2009, Assessment Framework – Key Competencies in Reading, Mathematics and Science*. Paris: OECD Publishing.
- Powell, A., Borge, I., Fioriti, G., Kondratieva, M., Koublanova, E., & Sukthankar, N. (2009). Challenging tasks and Mathematics learning. In E. Barbeau & P. Taylor (Eds.), *Challenging Mathematics In and Beyond the Classroom – New ICMI Study Series 12* (pp. 133-170). Springer.
- Protasov, V., Applebaum, M., Karp, A., Kasuba, R., Sossinsky, A., Barbeau, E., & Taylor, P. (2009). Challenging Problems: Mathematical Contents and Sources. In E. Barbeau & P. Taylor (Eds.), *Challenging Mathematics In and Beyond the Classroom – New ICMI Study Series 12* (pp. 11-52). Springer.

- Silver, E. (1997). Fostering creativity through instruction rich in mathematical problem solving and problem posing. *ZDM*, 3, 75-80.
- Smith, M., & Stein, M. K. (2011). *Five practices for orchestrating productive mathematics discussions*. Thousand Oaks, CA: Corwin Press.
- Vale, I., & Pimentel, T. (2011). Creativity, problem solving and problem posing. In B. Ubuz (Ed.), *Proceedings of the 35th Congress of the International Group for the Psychology of Mathematics Education, Vol. 1*, p. 511. Ankara, Turkey: PME.

TEACHERS' INVOLVEMENT AND LEARNING IN A LESSON STUDY

João Pedro da Ponte, Marisa Quaresma, Mónica Baptista, Joana Mata-Pereira

Instituto de Educação, Universidade de Lisboa

jpponte@ie.ul.pt, mq@campus.ul.pt, mbaptista@ie.ul.pt,
joanamatapereira@campus.ul.pt

The aim of this study is to analyse the way a group of basic education teachers got involved in a lesson study and their views, as they discuss the features of tasks, students' expected difficulties and how to conduct exploratory work in the mathematics classroom. The conceptual framework draws on notions of task design and considers the features of lesson study. Data collection was made through a research journal made by one of the authors in the role of observer, video recording with transcription of the sessions, teachers' written reflections and interviews. The results underscore the value of focusing on students' reasoning in working in mathematical tasks as well as the need to address affective issues, regarding the way teachers are invited to become involved and participate in lesson studies.

INTRODUCTION

Exploratory mathematics teaching is receiving an increasing support in international curriculum orientations for mathematics education (e.g., NCTM, 2000). In this approach students are called to deal with tasks for which they do not have an immediate solution method (closed problems and open problems). This represents an important departure from the didactical tradition in which the teacher just presents tasks that the students were already taught how to solve. In this tradition, the teacher begins by demonstrating the solution method and after presents the tasks for the students to practice it. With exploratory teaching, quite on the contrary, to solve the proposed tasks the students have to construct their own methods using their previous knowledge.

Exploratory work in the mathematics classroom creates opportunities for students to build or deepen their understanding of concepts, procedures, representations and mathematical ideas. Students are thus called to play an active role in the interpretation of the questions proposed, the representation of the information given and in designing and implementing solution strategies, which they must be able to present and justify to their colleagues and to the teacher. However, conducting exploratory mathematics teaching is a serious challenge for teachers, demanding specific knowledge, competency and disposition. In this paper we analyse the way a group of grade 5 and 6 teachers got involved in a lesson study and their emerging views on students' learning as they discuss the features of tasks and consider the possibilities for students' exploratory work in the mathematics classroom.

TASKS IN THE MATHEMATICS CLASSROOM

If mathematics teaching is mainly based on teacher lecturing, the concept of task is of little use. On the contrary, if mathematics teaching values the active role of students, this concept is essential, since tasks are a critical organizing element of the students' activity. However, tasks may play a variety of roles. The main goal of some tasks is to support learning, others are used to verify students' learning (assessment tasks), and, finally, others aim to get a deep understanding of students' capabilities, thinking processes and difficulties (research tasks).

Pólya (1945) draws a distinction between exercises and problems. Expanding this distinction, Stein and Smith (1998) present a typology of classroom tasks based on students learning. They distinguish between tasks with low and high level of cognitive demands. In the low-level cognitive tasks they make a distinction between: (i) "memorization" and (ii) "procedures without connections". In tasks with high cognitive demand, they distinguish between: (iii) "procedures with connections" and (iv) "doing mathematics". Stein and Smith illustrate these different categories using examples such as tasks that request students to define the relationship between different forms of representing a number as a fraction, decimal or percentage.

Skovsmose (2001) compares "exercises" with "landscapes for investigation", which include project work. Landscapes for investigation invite students to ask questions and seek explanations. However, it is necessary that students accept the teacher's challenge. The author also states that tasks rely on three major types of references – mathematics, real life, and "semi-reality" – i.e., situations that seem real, but in fact they are artificial and exclusively designed for learning. Based in these notions, the author identifies six types of learning environments but warns that the dividing lines between these environments are fluid and so students often move between them. He also points out that mathematics education should not be placed exclusively in an environment, but rather it should facilitate movement across them. In his view, the difficulties that such work creates to teachers, forcing them to modify the "didactic contract" implicitly established with students, places teachers on a "risk zone". As the author indicates, to work in such way teachers should look for support from their colleagues, working in collaborative settings.

Ponte (2005) indicates that tasks have two fundamental dimensions: mathematical challenge and structure. The degree of mathematical challenge (low/high) depends on the perception of the difficulty for a given person. On the other hand, the degree of structure (open/closed) refers to the nature of the statements regarding givens, goals, and conditions, which may be more or less detailed and open to interpretation. Crossing the two dimensions, we obtain four types of task: exercises are closed tasks presenting low mathematical challenge, problems are also closed tasks, but with a high degree of mathematical challenge, investigations are open tasks that present high mathematical challenge, and explorations are relatively open and have some challenging features for most students.

When teachers plan their work, they usually consider various types of tasks. Ponte (2005) suggests that diversification is necessary because each type of task plays a specific role in learning. Closed tasks (such as exercises and problems) are important for students' development of mathematical reasoning, which is based on a strict relationship between givens and results. Tasks with a small degree of challenge (as explorations and exercises) facilitate students achieving high rates of success and promote their self-confidence. More challenging tasks (as investigations and problems) are crucial to provide students deep mathematical experiences. Finally, open tasks are essential to help students to develop certain capacities, such as autonomy and ability to deal with complex situations.

This author points out that a certain task can be an exploration or an exercise, depending on students' prior knowledge. He also indicates that, in mathematical work, students mobilize knowledge they built outside of the school context. Contrary to the idea that students cannot carry out a task if they have not been taught directly how to solve it, the author notes that students learn out of school much knowledge they can mobilize in the mathematics classroom – and that is what exploratory tasks seek to promote. He also values students (re)discovery of a method for solving a question, and points out that this is often the best way to learn.

Ponte (2005) also considers that it is possible to diversify tasks by attending to context and the complexity of the work. The teacher should propose tasks in real contexts, so that students realize how mathematics is used in such contexts, and to take advantage of their knowledge of these contexts (application and modeling tasks). However, students may also feel challenged by tasks formulated within mathematical contexts (investigations, problems, explorations). By solving these tasks students may also understand how professional mathematicians develop their mathematical activity. In his view, in addition, tasks must provide a process of consistent learning, that facilitates students' construction of concepts, understanding of procedures, as well as increased knowledge of relevant representations and of connections within mathematics and within others domains. In order to achieve this goal, teachers must make decisions, define educational journeys and select tasks carefully. So, more than isolated tasks, teacher must organize sequence of tasks.

TEACHERS' PROFESSIONAL LEARNING IN A LESSON STUDY

Lesson study is a process to foster teachers' professional development. Recently it has gained international attention and it has been increasingly used in different grade levels, including higher education. A very important feature is that lesson studies take place within the school environment, where teachers play a central role. Usually, a lesson study begins with the identification of a relevant issue related to students' learning. Afterwards, the participants plan a lesson together considering the curriculum guidelines. They also predict students' difficulties, anticipate questions that might emerge in the classroom, formulate teaching strategies, and prepare the instruments to observe the lesson. The lesson is taught by one of the teachers with the others observing

and taking notes paying special attention to students' learning. When the lesson is over the teachers meet together to analyse and reflect on the observed lesson. The analysis may lead to the reformulation of the lesson plan, to a change in the strategies and materials used, in the tasks proposed, in the questions asked to the students, etc... Frequently, a revised lesson is later taught by another teacher to other class, in cycles that may be repeated several times (Lewis, Perry, & Hurd, 2009; Murata, 2011). A central aspect of lesson studies is that they focus on students' learning and not on teachers' work. This distinguishes lesson studies from other observation processes which focus mainly on what teachers do. Indeed, lesson studies aim to examine students' learning and to observe, up close, the way they learn. When participating in lesson studies, teachers can learn about important professional issues, in relation to the teaching subject, curriculum guidelines, students' processes and difficulties, and classroom dynamics.

Undertaking a lesson study has many problematic features, concerning the way teachers regard their own work in the classroom and how they relate to each other and to outsiders. A lesson study may challenge the notion that teachers have how a class must be organized, what tasks may be proposed, how they may be conducted. Requiring teachers to work together, it may give raise to personal conflicts and difficulties in handling criticisms. That is, lesson studies may provoke many uncomfortable moments in participating teachers. Reporting on a series of lesson studies involving novice teachers, Carter, Gammelgaard and Pope (2006) indicated that "Throughout the process each year, participants report a variety of feelings. Journal entries over the years have included statements of fear, excitement, anger, elation, weariness, frustration, and success" (p. 131).

Lesson studies are meant to be collaborative endeavors. Participants may create a close relationship, getting ideas from each other but also mutual support (Boavida & Ponte, 2002). In this way, lesson studies create a context not only for teacher reflection but also for the development of the sense of confidence that is central to teacher development. As Hargreaves (1995) indicates:

While reflection is central to teacher development, the mirror of reflection does not capture all there is to see in a teacher . . . However conscientiously it is done, the reflective glance can never quite get to the emotional heart of teaching . . . Understanding the emotional life of teachers, their feelings for and in their work, and attending to this emotional life in ways that positively cultivate it and avoid negatively damaging it should be absolutely central to teacher development efforts. (p. 21)

This close attention to didactical, mathematical, curricular, educational, and even political factors that are present in teachers' activity and professional development has to take into account all emotional aspects that may emerge and even get control over the educational processes.

RESEARCH METHODOLOGY

This research is conducted in the context of a lesson study carried out in a cluster of schools in Lisbon. This lesson study had its origin in a project developed by the cluster for which the principal asked the collaboration of the Instituto de Educação da Universidade de Lisboa (IE) to promote the professional development of the mathematics teachers. We proposed to carry out several lesson studies with teachers at different school levels and it was agreed that one of them would be undertaken with a group of grades 5-6 teachers (Inês, Francisca, Luísa, Maria, and Tânia) invited by the director of the cluster that also designated one of these teachers (Maria) as leader of the group. In a first preparatory meeting (with the participation of Maria) it was decided that the lesson study would concern a grade 5 topic (this grade was taught by three teachers of the group) since at this grade there was a new 2013 syllabus being applied and that could help the teachers to understand better how to deal with this syllabus, which was for them a major concern.

The first lesson study session was led by three members of the IE team (João Pedro, Marisa, and Joana) and the remaining sessions by two members (Marisa and Joana). These sessions usually take place every two weeks. In the sequence, we analyse four of the eight planned sessions that illustrate the working setting in this kind of teacher professional development context. Session 1 sought to present lesson study to the whole group of teachers, sessions 2 to 6 to deepen their knowledge about a topic and prepare a lesson on that topic, session 7 to observe a lesson, and session 8 to reflect on the observed lesson and on the whole lesson study process. Data collection is made through a research journal made by a member of the IE team in the role of observer, video recording with transcription of the sessions. We also collected but do not analyse here are teachers' written reflections and responses to interviews.

Data analysis has begun by identifying critical moments in sessions 1-4, looking at session transcripts and, when useful, to the video recording. We then categorized the identified episodes according to features that we considered of interest, regarding teachers' involvement in the session activity as well as regarding the key didactical issues emphasized in our conceptual framework: the nature of tasks, the identification of students' difficulties, attention to students' representations and students' reasoning. From this set of episodes we selected those that appeared to us more telling about the way this lesson study unfolded and about the teachers' participation, which we seek to interpret and analyse with our theoretical lenses.

RESULTS

A difficult beginning

The first session of the lesson study was mostly a presentation of the participants and of the work to be carried out. A most salient part of this session was the noticeable resistance from the teachers regarding the proposal to do a lesson study. Their participation in the lesson study was not their initiative – they were invited by the

director of the cluster of schools. In the presentation meeting we had explained to Maria, the coordinator of the group, what a lesson study was, and got the idea that she was convinced about its value and feasibility, but in this session she led the group in asking many questions about it. For example, she asked why to concentrate on just one topic if there is a new mathematics syllabus with many new features that the teachers are not sure how to deal with. We argued back that it was more productive to concentrate in just one topic in depth than to look superficially at many topics. She and other teachers as well, indicated to be uneasy with the idea of their classes being observed by others. We replied saying that in these observations the focus of interest was the students' reasoning and not the teacher's actions, but they did not seem very convinced. There were also questions regarding the attitude of the students in the presence of external observers. We indicated that in our former experiences in lesson study that was not a problem at all. Our arguments were not completely convincing but, finally, the proposal for the overall plan of the lesson study was approved by the teachers. As the topic to focus the attention in this study, the teachers chose rational numbers. In a later session they would define in a more precise way that the lesson to observe would concern teaching ordering, comparing, and equivalence of rational numbers. When the session was over, our team had the impression that this lesson study was going to be a disaster.

Identifying students' difficulties in mathematical tasks

In session 2, among other activities, we presented the teachers with a set of tasks, including exercises, problems, and explorations, and invited them to discuss the characteristics of these tasks and possible students' difficulties. This provided a good opportunity for teachers to reflect about different features of tasks.

We presented the taxonomy of tasks as exercises, problems, explorations and investigations. The first two terms were familiar to the teachers and they used them a lot during this whole session ("exercise", 19 times; "problem", 48 times), whereas they never used the terms "exploration" or "investigation". We may conclude that these two terms are not part of their usual professional vocabulary.

The last aspect of the presentation of the taxonomy on tasks, was a comment that a task is not a problem because it has a story attached to it, but because the students do not have a ready to use solution method. If they have such method, the task is just a simple exercise. This notion was a surprise for Maria, for whom a question with a story was a problem, regardless of its difficulty:

Maria: When they have all the data that means it is an exercise...? [So an exercise] is an application, it is an application of knowledge, and not . . . Whereas a problem is a little bit more than that, they have to discover something... They have to apply what they already know.

This new notion of problem seemed to make sense to Maria and to the other teachers, and, slowly, began to inform the discussion in the lesson study.

The first reaction regarding the tasks proposed for analysis, from Inês, was that “this kind of exercises is quite advanced”. This teacher argued a lot for her position, and got support from several others, like Luísa and Francisca. However, at some point, Luísa and Maria began saying that some of their students could solve one or another task:

Maria (in question 2): If they transform everything in decimal numbers...

Luísa: Yes.

Marisa: Exactly.

Francisca: It is very easy.

Tânia: From here they go on very well.

Maria: Yes.

Luísa: Yes.

...

Luísa: Leaving aside question 3.2, that I think that they would get [the answers], the others no. And the 25% of the figure, some [students] I think would not get it.

Maria: Most [students] would not do them [the tasks]. I have one or another [student] who would do.

...

Maria: Everything involving decimal numbers they would get it.

Luísa: Yes, maybe.

Maria: Perhaps they would get there. So, they would count . . .

Tânia: To do this one they would need to have the notion of equivalent fractions...
If they have the notion of equivalent fractions [they can solve it]...

This was the beginning of the discussion of the full set of tasks. In the sequence, as the teachers considered every task in turn, they found many cases in which their students could possibly solve the proposed questions. Inês still argue in several moments that this set of tasks would fit better grade 6 students, and it would be very difficult to grade 5 students. However, as the tasks were discussed one by one, the other teachers found many situations that their students could have ease to do and others that, whereas not so easy, they still could perhaps handle.

Later on in this session, Tânia made an important point about the role of representations:

With the representation it [this task] is quite simple because when we do the representation and after we say that it is $\frac{1}{3}$ or it is $\frac{2}{5}$ of that, so we divide, all right? And then we say that it is only $\frac{1}{4}$ of that, it is easy! Now, without the representation it is not so easy for them to

do [the question]. What they usually do is: they multiply and divide. Because they have that . . . Usually grade 6 students do it this way.

When Tânia says “representation” she means “pictorial representation”. This teacher voiced an important idea, that the difficulty of a task depends on the representation in which the task is formulated, and teachers should promote the use of pictorial representations along with the more formal representations of rational numbers as fractions and decimal numbers.

The tasks in which a part is given and questions are made about other parts promoted a lot of discussion among teachers. For students that do not know operations with rational numbers, such tasks require them to do two steps – first to construct the unit, given a part, and then find the required new part. The teachers had to think for a while how to handle such tasks themselves:

Maria: How would you approach this? I am sorry! This is $\frac{3}{4}$ and now how would you ask $\frac{1}{2}$? How do they...?

Marisa (IE): What could be the first step?

(silence for 5 seconds)

Maria: Any suggestion?

Inês: It is to add a little bit that is missing.

Marisa (IE): First they need to understand what is then the...

Teachers: [All at the same time] The unit!

Dealing with tasks that had some elements of challenge created some excitement on teachers. For example, at some point in this session, during the discussion of another problem, Maria commented

But this is interesting, I like it a lot: the construction of the unit. To begin from here to construct the whole, and then the representations – having the unit to be divided by three or to be divided by two...

It became apparent early in this session that the teachers were not used to the meanings of terms that are quite important to speak about features of tasks, neither to distinguish among different kinds of tasks. For example, to mean “problem”, Inês speaks of “advanced exercises”. We decided to introduce some elements of this vocabulary and then use them informally expecting that the teachers to appropriate it.

An important feature of the discussion was the encouragement to teachers to make connections to their own professional experience. Some of the teachers – especially Maria and Tânia – made this several times, with great excitement. In other occasions, it was Marisa (from the IE team) that reported on her experience showing how her students managed tasks that the participating teachers found too difficult for their students. This close relation to professional practice brought an important element of

authenticity that seemed to be powerful in letting the teachers to reflect on the issues under discussion.

During this discussion there were several opportunities for the teachers to see what the guidelines of new syllabus were. They were quite surprised with things that they did not notice, and all of them were very critical about some issues such as task with a subtraction of two mixed numbers in which the fraction of the number to be subtracted is small than the other fraction. The wide consensus that the teachers achieved regarding these curriculum documents appeared to be reassuring for them and provide some confidence to work with this new approach from a critical stance.

However, it also appeared that these teachers are not much used to propose tasks with challenging features, fearing that the students simply cannot solve them. A very important point is that, in this session, at least some of the teachers appeared to start thinking that challenging tasks could also be presented to students, at least to some of them, given the appropriate conditions. They could see that grade 5 students (at least some of them) could handle tasks that went beyond what they usually propose, with positive results. This attention to the features of tasks and to students' difficulties in solving them appeared to be a new notion to several teachers of the group that got very involved in many moments of the session, showing their excitement (as we illustrated with a comment from Maria). What looked like a disaster lesson study became at this point a very promising professional development activity.

Identifying students' achievements

In session 3 the teachers designed a set a diagnostic tasks to know about students' knowledge on rational numbers. One of the aims of session 4 was to analyse the results. Seeking to overcome the teachers' usual tendency to just focus on students' difficulties, Marisa began by asking the teachers about situations in which they were positively surprised with students' work. She had been to Maria's classes where the diagnostic test was administered and had analysed the results of one class. She offered herself to begin by pointing aspects that she found very interesting and gave several examples of interesting achievements. However, when it was the teachers' turn, what emerged was again their focus on students' difficulties. For example, Francisca said:

Regarding [my class] children painted with ease the fractions, but many times they did not made the fraction representation. They only read a half, that's it. After, in this [question 3], they had more difficulty exactly in $\frac{1}{4}$ and in $\frac{1}{8}$. It was very difficult for them.

Francisca goes on saying that students managed to paint with ease a half and one third of the pictures presented to add in the sequence a new set of difficulties. Marisa insisted in reorienting the discussion towards the positive surprises:

Marisa: Perhaps we do the surprises first and then the difficulties.

Francisca: Surprise, surprise, was in exercise 4. They were easily able to get $\frac{1}{4}$ of the chocolate. I found that very cute because they already know how to do the computation [$\frac{4}{4} - \frac{3}{4} = \frac{1}{4}$], I was not expecting that.

In this way, Francisca referred some positive aspects of students' work. However, in her second intervention, she came back to difficulties:

Francisca: So, they made this, I found... This is where I found that that they had more difficulties.

Marisa: Difficulties, no. Surprises. Any other [question] that you were expecting that they would not solve?

Francisca then mentioned another surprise in her students' solutions, referring the knowledge that students have about the different representations of rational number:

Francisca: My surprises were really here in task 4. I found that fantastic. This representation of fraction, decimal and percent, that I thought that most of them would not be able to do, and most did.

Tânia is the last teacher to present her surprises in her students' work. She began by addressing these aspects perhaps having figured out the implicit message of the member of the IE team indicating that positive features were not to be overshadowed by continuous mention to students' difficulties. In the continuation she made an interesting reflection about the changes in students' knowledge provided by the 2007 mathematics syllabus:

Tânia: And it is the fact that they already represent equivalent fractions.

Marisa: They represent what?

Tânia: For example, in the past [before 2007], when they arrived here, we had to begin by all this phase, because they know what was $\frac{1}{4}$, $\frac{1}{2}$, but not more. No, now they already know what is $\frac{3}{8}$, $\frac{3}{5}$, so.....

Marisa: In questions 1 and 2, they represent with equivalent fractions?

Tânia: Yes, yes.

Inês: So they come more developed.

Tânia: So, this first phase I think that we need to go ahead because we have to assume that this is learnt, because we see that this was worked in class. I have many... For example, here, they write the fraction but they write $\frac{1}{2}$ in all; so they decided that instead of placing $\frac{4}{8}$, $\frac{3}{6}$, they put $\frac{1}{2}$ in all. But, so, it is correct, it is one half, it is the equivalent fraction.

With this intervention, Tânia reflects about the changes that need to be made in teachers' practice in consequence of the changes introduced by the 2007 syllabus, as students got to learn about equivalent fractions through grades 1-4.

In the beginning of the discussion, teachers' comments systematically focused more on students' difficulties than identifying what they were able to do. However, with systematic encouragement from the IE team to focus on positive surprises, the teachers began to note and comment on interesting aspects of students' work. The fact that Marisa went to observe a class of one of the participating teachers and had some

examples from this class provided an important support to the notion that there were indeed interesting things to mention. In this session we see the teachers reflecting with more confidence on issues related to the influence of curriculum documents on their teaching activity, recognizing that because of curriculum changes they can rely on the students' knowledge about equivalent fractions.

Recognizing different kinds of tasks and noticing students' reasoning

Session 4 included a discussion about the nature of tasks. We began by briefly presenting the main features of exercises, problems, explorations and investigations, referring to several examples. Tânia present a reflection about the distinction among problems and exercises based on examples from her own practice. She shows to understand that what students know is critical to establish this distinction, so that a task that is a problem for a student at a given point later may become a simple exercise. It is also noticeable that the teachers put a high value in students' work in explorations. Francisca and Luísa recall an experience from her own practice in which the students explored, with manipulative materials, the sum of the angles of a triangle. They referred that such discovery was very important for students that “would no longer forget”.

In this session there was also some discussion about reasoning processes and analysis of students' solutions. We began by addressing the notions of generalization and justification which the teachers seemed to have not much trouble in appropriating. Observing the students solutions (figures 1 and 2), Tânia and Inês are able to note easily both generalizations and justifications.

	<p><i>No, because the example of</i></p> <p><i>7:4=1,75 and 5:2=2,5</i></p> <p><i>1,75 < 2,5 and this</i></p> <p><i>means that it [the statement] is not true.</i></p>
---	---

Figure 1. Identifying a justification.

Tânia: It is more a justification; he searched an example.

Observing the response of the students in figure 1, Tânia quickly identifies that the students use a counter-example to refute a statement and, therefore, they were providing a justification. Analysing the solution presented in figure 2, Inês identifies the justification in a): “Here, this is a justification”. She recognised that the students used another representation to verify the statement.

Quickly Tânia moved to b) and identifies the generalization:

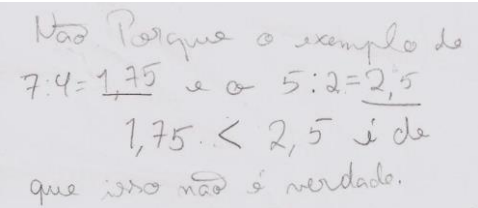
Tânia: But the, in the other, they have already another little generalization.

Joana: In the other they have another small generalization. That is not so small.

Tânia: It is not for all [students].

<p>Is it $\frac{2}{4} = \frac{8}{16}$?</p> <p>Yes.</p> <p>$0.5 = 0.5$</p> <p>Provide one or more justifications to your previous answer.</p> 	<p><i>A number divided by its double is equal to 0.5</i></p>
--	--

Figure 2. Identifying a generalization.

Given this recognition and the way Tânia states it, we decided to stress not just her discovery but also the work of the students so that the teachers understand the nature of this work and the importance of including it in their classes.

CONCLUSION

The results show that the teachers began their participation in the lesson study very suspicious about this activity. However, the fact that they could work on mathematical tasks and analyse students' solutions, with reference to their own experience, promoted their quick involvement. The carefully planned sessions and the environment of open questioning of issues, respect for everyone's ideas, argumentation supported on classroom data and also on research results yielded an atmosphere of interest and trust of a collaborative setting (Boavida & Ponte, 2002). As teachers began realizing that they had much to learn about their students' learning and their own learning on this topic, there were no more suggestions that we should be doing something else.

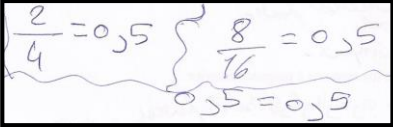
The whole experience of the lesson study is much richer than what we can glimpse in just a few sessions. However, we see the value of focusing on students' reasoning in working in mathematical tasks, with the possibility for teachers to notice important features of tasks that make them simple exercises or more engaging problems or explorations (Ponte, 2005; Skovsmose, 2001), as well as features of reasoning processes such as justification and generalization (Lannin, Ellis, & Elliot, 2011; Ponte, Mata-Pereira, & Henriques, 2012). Anticipating possible difficulties of students and looking at what they actually do in the classroom are key features of lesson study (Alston, Pedrick, Morris, & Basu, 2011) that proved to be very effective in leading the teachers to reflect and consider changes in their classroom practice. The attention to affective issues, regarding the way teachers are invited to become involved in lesson studies, the collaborative environment provided, and the activity that they have opportunity to undertake also appear as critical design factors (Loucks-Horsley, Hewson, Love, & Stiles, 1998) for the success of this activity.

REFERENCES

Alston, A., Pedrick, L., Morris, K., & Basu, R. (2011). Lesson study as a tool for developing teachers' close attention to students' mathematical thinking. In L. Hart,

- A. Alston, & A. Murata (Eds.), *Lesson study research and practice in mathematics education* (pp. 135-152). Dordrecht: Springer.
- Boavida, A. M., & Ponte, J. P. (2002). Investigação colaborativa: Potencialidades e problemas. In GTI (Ed.), *Refletir e investigar sobre a prática profissional* (pp. 43-55). Lisboa: APM.
- Carter, J., Gammelgaard, R., & Pope, M. (2006). Navigating the learning curve: Learning to teach mathematics through lesson study. In L. R. Van Zoest (Ed.), *Teachers engaged in research: Inquiry into mathematics classrooms, grades 9-12* (pp. 119-133). Reston, VA: NCTM.
- Hargreaves, A. (1995). Development and desire: A postmodern perspective. In T. R. Guskey & M. Huberman (Eds.), *Professional development in education: New paradigms and practices* (pp. 9-34). New York, NY: Teachers College Press.
- Lannin, J., Ellis, A. B., & Elliot, R. (2011). *Developing essential understanding of mathematical reasoning: Pre-K-Grade 8*. Reston, VA: NCTM.
- Lewis, C., Perry, R., & Hurd, J. (2009). Improving mathematics instruction through lesson study: A theoretical model and North American case. *Journal of Mathematics Teacher Education*, 12, 285-304.
- Loucks-Horsley, S., Hewson, P. W., Love, N., & Stiles, K. E. (1998). *Designing professional development for teachers of science and mathematics*. Thousand Oaks, CA: Corwin Press.
- Murata, A. (2011). Conceptual overview of lesson study. In L. Hart, A. Alston, & A. Murata (Eds.), *Lesson study research and practice in mathematics education* (pp. 1-12). Dordrecht: Springer.
- NCTM (2000). *Principles and standards for school mathematics*. Reston: NCTM.
- Pólya, G. (1945). *How to solve it: A new aspect of mathematical method*. Princeton: Princeton University Press.
- Ponte, J. P. (2005). Gestão curricular em Matemática. In GTI (Ed.), *O professor e o desenvolvimento curricular* (pp. 11-34). Lisboa: APM.
- Ponte, J. P., Baptista, M., Velez, I., & Costa, E. (2012). Aprendizagens profissionais dos professores de Matemática através dos estudos de aula. *Pesquisas em Formação de Professores na Educação Matemática*, 5, 7-24.
- Ponte, J. P., Mata-Pereira, J., & Henriques, A. (2012). O raciocínio matemático nos alunos do ensino básico e do ensino superior. *Praxis Educativa*, 7(2), 355-377.
- Skovsmose, O. (2001). Landscapes of investigation. *ZDM*, 33(4), 123-132.
- Stein, M. K., & Smith, M. S. (1998). Mathematical tasks as a framework for reflection: From research to practice. *Mathematics Teaching in the Middle School*, 3(4), 268-275.

E-POSTERS

TEACHING AND LEARNING MATHEMATICS FOR CREATIVITY THROUGH CHALLENGING TASKS

Ana Barbosa*, Isabel Vale*, Teresa Pimentel**

* School of Education of the Polytechnic Institute of Viana do Castelo, Portugal,

**Secondary School of Santa Maria Maior, Portugal

anabarbosa@ese.ipvc.pt, isabel.vale@ese.ipvc.pt, terpimentel@gmail.com

Tasks greatly influence what students learn, mainly if they lead to the understanding of structural mathematical concepts and encourage creative thinking. Research findings show that mathematical problem solving and problem posing are closely related to creativity (e.g. Leikin, 2009; Silver, 1997). Tasks that can promote fluency, flexibility and originality as components of creativity must be open-ended and ill structured, assuming the form of problem solving and posing in mathematical explorations. These environments where students use diverse strategies and formulate their own problems allow them to be involved, increase their motivation and encourage them to investigate, to make decisions, to look for patterns and connections, to generalize, to communicate and to identify alternatives. Based on these assumptions, we developed a still ongoing study, with future elementary school teachers (3-12 years old), addressing the following question: How do the productions done by future teachers, of the proposed tasks with multiple (re)solutions and which privilege figurative contexts, provoke some dimensions of students creativity, and what features of the tasks can engage students in their resolution? We developed a didactical experience through a qualitative approach. Data was collected in a holistic, descriptive and interpretive way, including mainly classroom observations, methodological notes and productions of the students. In this study, we propose a model for challenging tasks, in elaboration, that incorporates ideas from problem solving (e.g. Silver, 1997) and problem posing (Brown & Walter, 2005; Silver, 1997; Stoyanova, 1998). The productions of future teachers suggest some characteristics of creativity (e.g. multiple representations, multiple ways of solving, different types of problems formulated). The most well succeeded tasks were those related with visual patterns. The productions related to problem posing tasks revealed less creativity as divergent thinking. We must look for adequate classroom strategies to encourage future teachers to seek unusual and original responses and, on the other hand, be more confident and efficient in teaching.

REFERENCES

- Brown, S. & Walter, M. (2005). *The art of problem posing*. Mahwah, NJ: Erlbaum.
- Leikin, R. (2009). Exploring mathematical creativity using multiple solution tasks. In R. Leikin, A. Berman and B. Koichu (Eds.), *Creativity in mathematics and the education of gifted students* (pp. 129-145). Rotterdam, Netherlands: Sense Publishers.

- Silver, E. (1997). Fostering creativity through instruction rich in mathematical problem solving and problem posing. *International Reviews on Mathematical Education, Essence of Mathematics*, 29(3), 75–80.
- Stoyanova, E. (1998). Problem posing in mathematics classrooms. In A. McIntosh & N. Ellerton (Eds.), *Research in Mathematics Education: a contemporary perspective* (pp. 164-185). Edith Cowan University: MASTEC.

DEVELOPING POSITIVE DISPOSITIONS TOWARD MATHEMATICAL PROBLEM SOLVING

Luis Conde, Mehmet Türeğün

Barry University, United States of America

lconde@barry.edu, mturegun@barry.edu

In this poster presentation the connections among technology, creativity, and attitudes towards mathematical problem solving are examined. A detailed outline of a particular design, which weaves a single common curricular thread by using technology, infusing creativity, and imparting positive dispositions toward mathematical problem solving among students and teachers, is presented. The perceptions and attitudes of a group of in-service teachers toward a creative mathematical problem solving activity with a particular application to estimating the area of irregularly shaped polygons are also investigated.

To establish connections among creativity, technology, and mathematical problem solving, we discuss the creativity piece in the form of Tangrams, one of the oldest Chinese puzzles/games from which an infinite number of shapes can be created. In our poster presentation, we demonstrate the use of tangrams as a manipulative to teach mathematics and geometry. We aim to inspire observation and logical thinking among teachers and school children, and to promote development of geometric and mathematical vocabulary and discovery of relationships among 2-dimensional geometric shapes. A Concrete-Representational-Abstract (CRA) instructional approach is also presented using hands-on activities and materials to acquire and retain mathematical concepts.

POSING AND SOLVING PROBLEMS IN MATHEMATICAL MODELING SCENARIOS

Cristina Esteley*, María Mina**, Mónica Villarreal***

* Universidad Nacional de Córdoba, ** Colegio Gabriel Taborin, *** Universidad Nacional de Córdoba-CONICET

esteley@famaf.unc.edu.ar; mmina@taborin.edu.ar; mvilla@famaf.unc.edu.ar

Problem solving, problem posing and mathematical modeling are important for mathematicians as well as for students learning mathematics. These three activities are strongly related. Nevertheless, problem solving and problem posing gain distinctiveness when they take place in modeling scenarios in which the students, working in small groups, choose to study a real-world theme and pose problems related to it. This particular modeling approach, in which the students are free to select themes and pose problems to solve, opens the possibility of critical understanding of the surrounding world. At the same time the students have the opportunity of taking decisions, sharing their findings with the entire class and reformulating their problems.

Borba and Villarreal (2005) assert that some distinctive features of problem posing in such scenarios are: the interdisciplinary character of the problems, the non-internalist view of mathematics, the encouragement of autonomy, the participation and collaboration among students, and the opportunity of making sense of mathematical activity related to some aspects of the real world. According to Stoyanova (2000), we can say that, in a mathematical modeling scenario, the students experience a problem posing task in a *free situation*.

In this poster we present and analyze examples of problems posed by 11-12 years old students from secondary school in Argentina. We selected those problems because they reveal creative work. The dimensions of analysis are the main features of problem solving as described by Borba and Villarreal (2005) The examples selected are related to environmental themes or socio-economical issues, etc, such as: How many trees are cut down to produce a block of sheets of paper? What is the demand for water consumed by a family of 4? Finally, we will show the way that some initial questions posed by the students were reformulated.

REFERENCES

Borba, M., & Villarreal, M. (2005). *Humans-with-media and the reorganization of mathematical thinking: Information and communication technologies, modelling, experimentation and visualization*. New York: Springer.

Stoyanova, E. (2000). Empowering students' problem solving via problem posing: the art of framing "good" questions. *Australian Mathematics Teacher*. 56(1), 33-37.

DROIDE II – ROBOTS IN MATHEMATICS AND INFORMATICS EDUCATION – FINAL RESULTS OF THE PROJECT

Elsa Fernandes

University of Madeira & UIDEF, Institute of Education, University of Lisbon

elsa@uma.pt

In this poster we will present final results of project Droide II – robots in mathematics and informatics education – which aims to understand how the use of robots as mediating artifacts for learning contributes to the production of meaning and learning of mathematics and informatics topics and possible bridges between those two domains. We aim also to contribute to the understanding of participation in social digital learning environments where robots are fundamental elements of the learning scenarios. Taking a theoretical framework based on Situated Learning Theories and Activity Theory we created and implemented learning scenarios (one for primary school, two for middle school (mathematics), one for high school (informatics) and one in virtual environment in mathematics and informatics) where robots play an important role. We looked for evidence on (1) the learning of mathematics/informatics, through the identification and description of: a) the shared repertoire that students build within those practices; b) contradictions, in learning environments, emerging from the use of robots; c) mathematical and informatics competences developed in those scenarios; (2) contributions to learning that occurred from the participation in social digital environments, through the identification and description of: (a) how pupils made explicit/communicate ways of doing and thinking on those environments; (b) how pupils critically and constructively participated on those environments, (c) how pupils become aware of their own responsibility and initiative.

The practice that emerged from the implementation of the learning scenarios with robots can be characterized by the strong engagement of students within a joint enterprise, coming from the negotiation of the main aspects of the participation by all participants (students, teachers, researchers). Agency emerged in pupils that usually had a marginal participation in mathematics classes (Fernandes, 2013). In the school practices analyzed, the understanding of what was considered as competence was defined in the relationships in which mutuality was the basis of membership recognition by the community (Martins, 2013).

REFERENCES

- Fernandes, E. (2013). *Aprender Matemática e Informática com Robots*. Universidade da Madeira. Funchal. Retrieved from http://www.cee.uma.pt/droide2/ebook/ebook_vf.pdf
- Martins, S. (2013). ‘Regime of competence’ in a school practice with Robots. *Proceedings of the 8th Conference of European Research on Mathematics Education*. Turkey.

PROBLEM SOLVING: CARVING OUT SPACES FOR CREATIVITY, COMMUNICATION, AND PERSEVERANCE

Deborah Moore-Russo, Anne Izydorczak, Harry T. O'Malley

Gifted Mathematics Program, University at Buffalo

dam29@buffalo.edu

How students come to understand mathematics is very much part of how they engage with mathematics. In the spirit of Leander, Phillips, and Taylor (2007), we take the stance that schools are not containers but are breathing spaces filled with energies that flow in and out. While instructors may not select the students who play a major role in the learning spaces they create, instructors are able to select the types of activities in which their students engage.

In this poster, we report on one teacher in the Gifted Mathematics Program (GMP) at the University at Buffalo in New York. GMP is an after-school program where students from age 12 to 18 years take their mathematics courses at a university with other mathematically gifted students two evenings a week. The curriculum meets state requirements while also covering additional content not typically found in area schools. The instructor under study taught in the first year of the six-year program. This paper reports why and how he made a conscious decision to retool his first-year GMP course to create learning spaces built around a problem-solving curriculum.

Some of the goals in the retooled course, like promoting mathematical communication and perseverance in problem solving, are found respectively in a key document from the (U.S.) National Council of Teacher of Mathematics (2000) and another more recent U.S. mathematics curriculum document (Common Core State Standards, 2009). However, the instructor's third goal, that of promoting mathematical creativity did not make the "short list" of standards for either document. This presentation will review what is meant by mathematical creativity then consider how a problem-solving curriculum that focuses on students' mathematical engagement can carve out spaces for mathematical creativity, communication, and perseverance.

REFERENCES

- Common Core State Standards Initiative. (2010). *Common Core Standards for Mathematics*. Washington, DC: National Governors Association Center for Best Practices and the Council of Chief State School Officers.
- Leander, K. M., Phillips, N. C., & Taylor, K. H. (2010). The changing social spaces of learning: Mapping new mobilities. *Review of Research in Education*, 34(1), 329-394.
- National Council of Teachers of Mathematics. (2000). *Principles and Standards for School Mathematics*. Reston, VA: National Council of Teachers of Mathematics.

PROOF AND CREATIVITY IN A GEOMETRICAL PROBLEM FROM A REGIONAL MATHEMATICAL OLYMPIAD

Juan Rodriguez*, Nélia Amado**, Susana Carreira**, Sílvia Reis***

* University of Algarve and Centro de Análise Funcional e Aplicações, Portugal,

**University of Algarve and Research Unit of the Institute of Education, Portugal,

*** Group of Schools of Valpaços, Portugal

jsanchez@ualg.pt, namado@ualg.pt, scarrei@ualg.pt, silviapreis@hotmail.com

The Algarve Regional Olympiads in Mathematics (OCAM) started in 2005, aiming at involving junior high school students (13 to 15 years old) in a small regional competition. One of the several characteristics of this initiative is the involvement of school and university teachers, the latter from the Mathematics Department of the Science and technology Faculty of the University of Algarve, in a collaborative project around mathematics problem solving.

The OCAM have three phases: the qualifying phase, the regional finals, and the real final. The qualifying phase takes place in each basic school of the Algarve region. Four to five students of each basic school follow to the second phase and dispute two regional finals which take place in secondary schools. Out of the regional finals, 60 students reach the final, which is always during the month of May, at the University of Algarve.

Throughout these three phases, teachers do some preparation work with their students. These preparation activities are based on problems from previous editions of the Olympiads and problems from training sessions aimed at the teachers.

The tests of the Olympiads are elaborated by a team of university teachers and school teachers of the age level of the participants. Several team members solve the problems with the goal of gathering the largest possible number of resolutions for each problem. However, sometimes, the younger participants are able to surprise the organization and their own teachers by presenting solutions that never crossed the mind of the organization team.

We present two geometry problems proposed to students in different finals of these Olympiads. The problems were chosen because the students offered resolutions that were totally distinct from the ones predicted by the organization in the set of criteria constructed to guide the grading of the tests.

ACKNOWLEDGMENTS

This work is supported by national funds through Fundação para a Ciência e Tecnologia, under the project PTDC/CPE-CED/101635/2008.

INFORMATION ENVIRONMENT FOR MATHEMATICS EDUCATION BASED ON RELATIONSHIP DEVELOPMENT THEORY

Karasawa Toshimitsu

Yayasam Pelajaran Mara & University of Kuala Lumpur

karasawat10@gmail.com

Recently, with rapid growth in computer and network technologies, research on supporting intellectual cooperative work using information technology (ICT) is being promoted actively. In practice, many kinds of network cooperative work support systems, by which users can share information resources and related tasks on network environments, have been developed so far (Malone et al., 1994; Yoshino et al., 1999). The object of these systems is to accelerate the process of cooperative work among group members who physically exist in a distance. Examples of these systems are cooperative CAD system, support system for project-based software development, cooperative editing system, distance e-Learning system, etc. (Dasai et al., 1998; Yoshino et al., 1998; Lajoie & Vivet, 1999). Using traditional cooperative work support system, group members can pursue their jobs as if other members are physically close to them, even if they actually are in a distance. I propose a scheme to effectively support cooperative work by controlling information flow from real space (RS) to digital space (DS), and from DS to RS, based on the concept of “Relationship development theory”. In practice, my scheme controls availability of shared workspace in DS for cooperative work, according to the situation of tasks and workers in RS, in order to accelerate cooperative work, along with reinforcing the “value placed on information”. Using this scheme, advanced support to improve quality of intellectual cooperative work can be realized. In this paper, I apply my proposed scheme to group learning domain. This is an educational activity domain where group members including a teacher and several students cooperatively solve the given problems. Applying to this domain, I show that the proposed scheme, i.e., suitable availability control of shared workspace in DS, can accelerate the cooperative work. From experimental results, I found that the cooperative problem solving among teacher and students were accelerated. Also I confirmed that the learning outcomes were improved, by controlling availability of the shared workspace, according to the progress of the group learning process. From these results I evaluated the effectiveness of my proposal.

REFERENCES

- Dasai, T. et al. (1998). Support for Collaborative Distance Learning by Multi-agent Functions, *Transactions on IPSJ*, 39, pp. 199-210.
- Lajoie, S. P. & Vivet, M. (Eds). (1999). *Artificial Intelligence in Education*. Amsterdam: IOS Press.

- Malone, T., et al. (1994). The Interdisciplinary Study of Coordination. *ACM Computing Surveys*, 26, pp. 87-119
- Yoshino, T. et al. (1998). Development and Application of a Supporting System for Distance Learning Classroom Using Personal Computers via Internet, *Transactions on IPJS*, 39, pp. 2788-2801.
- Yoshino, T. et al. (1999). Development of a Multi-user Electronic Conferencing System: DEMPO III, *Transactions on IPSJ*, 40, pp. 150-160.

PROBLEM SOLVING IN MODELING SCENARIOS WITH EXPERIMENTAL ACTIVITIES: THE ROLE OF INFORMATION AND COMMUNICATION TECHNOLOGIES

Mónica Villarreal*, María Mina**, Cristina Esteley*

* Universidad Nacional de Córdoba - CONICET; **Colegio Gabriel Taborin
mvilla@famaf.unc.edu.ar; mmina@taborin.edu.ar; esteley@famaf.unc.edu.ar

The presence of information and communication technologies (ICT) in educational contexts has introduced changes related to the problems that can be solved mediated by ICT. At the same time, we can say that ICT empower modeling processes (Villarreal, Esteley & Mina, 2012) in which students can select a real-phenomenon to study, pose problems related to it, select variables, raise hypothesis, design experiments, search for information, deal with data and, finally, solve the problem. Connected to these ideas, Borba and Villarreal (2005) emphasize the role of experimentation in mathematics as well as in mathematics education, and they refer to the ways that ICT support the implementation of experimental-with-technology approaches in mathematics classrooms. According to these authors: “the association of experimentation, technology and modeling exhibits a natural resonance” (p. 76).

In this poster we present and analyze examples of experimental activities produced by 12-13 years old students from secondary school in Argentina, solving problems in modeling scenarios inside their mathematical classrooms. We will concentrate on the ways the students used technologies to design experiments and solve the problems they posed. The selected examples are related to physical phenomena. One of them is concerned with the falling of a marble down an inclined plane with different angles of inclination. The other one is concerned with a pendulum movement.

REFERENCES

- Borba, M., & Villarreal, M. (2005). *Humans-with-media and the reorganization of mathematical thinking: Information and communication technologies, modelling, experimentation and visualization*. New York: Springer.
- Villarreal, M., Esteley, C. & Mina, M. (2010) Modeling empowered by information and communication technologies. *ZDM The International Journal on Mathematics Education*, 42(3-4), 405-419. doi: 10.1007/s11858-010-0248-7

The process of peer reviewing was made possible by:

Ana Barbosa (Portugal)
Cinzia Bonotto (Italy)
Cristina Esteley (Argentina)
Guida de Abreu (United Kingdom)
Hélia Jacinto (Portugal)
Inés Gómez-Chacón (Spain)
Isabel Vale (Portugal)
João Filipe Matos (Portugal)
João Pedro da Ponte (Portugal)
Joaquin Giménez (Spain)
Juan Rodriguez (Portugal)
Keith Jones (United Kingdom)
Maria Madalena Dullius (Brazil)
Markku Hannula (Finland)
Marli Teresinha Quartieri (Brazil)
Matías Camacho-Machín (Spain)
Michal Tabach (Israel)
Milton Rosa (Brazil)
Mónica Villarreal (Argentina)
Nélia Amado (Portugal)
Norma Presmeg (USA)
Nuno Amaral (Portugal)
Rosa Ferreira (Portugal)
Sandra Nobre (Portugal)
Susana Carreira (Portugal)
Teresa Pimentel (Portugal)

LIST OF PARTICIPANTS

Ana Barbosa

Escola Superior de Educação, Instituto
Politécnico de Viana do Castelo
Portugal
anabarbosa@ese.ipvc.pt

Andrew Philip Kwok

Diocesan Boys' School Primary Division
China
kwokandrewphilip@gmail.com

Bárbara Cândido Braz

Universidade Estadual de Maringá
Brazil
babicbraz@gmail.com

Belmira Ribeiro da Mota

Universidade do Porto
Portugal
belmiramota@gmail.com

Bernard Parzysz

Laboratoire André Revuz, Université Paris-
Diderot
France
parzysz.bernard@wanadoo.fr

Cinzia Bonotto

University of Padova
Italy
bonotto@math.unipd.it

Cláudia Fernandes

Escola Secundária Manuel Teixeira Gomes
Portugal
claudiapcfernandes@gmail.com

Cristina Beatriz Esteley

Facultad de Matemática, Astronomía y Física -
Univ. Nacional de Córdoba
Argentina
esteley@famaf.unc.edu.ar

Daniel Orey

Centro de Educação Aberta e a Distância -
Univ. Federal de Ouro Preto
Brazil
oreydc@cead.ufop.br

Deborah Moore-Russo

University of Buffalo
United States of America
dam29@buffalo.edu

Elsa Fernandes

Universidade da Madeira
Portugal
elsa@uma.pt

Giovannina Albano

University of Salerno
Italy
galbano@unisa.it

Guida M. C. De Abreu

Oxford Brookes University
United Kingdom
gabreu@brookes.ac.uk

Helen Kinsella

Cranbrook School
Australia
hkinsella@cranbrook.nsw.edu.au

Hélia Jacinto

Unidade de Investigação do Instituto de
Educação da Universidade de Lisboa
Portugal
helia_jacinto@hotmail.com

Inés Gómez-Chacón

Mathematics Faculty, Complutense University
of Madrid
Spain
igomezchacon@mat.ucm.es

Isabel Vale

Escola Superior de Educação, Instituto
Politécnico de Viana do Castelo
Portugal
isabel.vale@ese.ipvc.pt

Italo Gabriel Neide

Centro Universitário Univates
Brazil
italo.neide@univates.br

Jaguthsing Dindyal

NIE, Nanyang Technological University
Singapore
jaguthsing.dindyal@nie.edu.sg

Jaime Carvalho e Silva

Universidade de Coimbra &CMUC
Portugal
jaimecs@mat.uc.pt

João Filipe Matos

Instituto de Educação da Universidade de
Lisboa
Portugal
jfmatos@ie.ulisboa.pt

João Frederico Meyer

Universidade de Campinas
Brazil
joni@ime.unicamp.br

João Pedro da Ponte

Instituto de Educação da Universidade de
Lisboa
Portugal
jpponte@ie.ul.pt

Joaquin Gimenez

Barcelona University
Spain
quimgimenez@ub.edu

Juan Carlos Sanchez

Faculdade de Ciências e Tecnologia,
Universidade do Algarve
Portugal
jsanchez@ualg.pt

Julie-Ann Edwards

University of Southampton
United Kingdom
j.s.edwards@soton.ac.uk

Julio César Paiva

Agrupamento Vertical Dr. Francisco Fernandes
Lopes
Portugal
juliopaiva@aeffl.pt

Karasama Toshimitsu

Yayasam Pelajara Mara Education
Foundation/University Kuala Lumpur
Malaysia
karasawat10@yahoo.co.jp

Keith Jones

University of Southampton
United Kingdom
d.k.jones@soton.ac.uk

Lilian Kato

Universidade Estadual de Maringá
Brazil
lilianakemikato@gmail.com

Lina Maria Dias Fonseca

Escola Superior de Educação, Instituto
Politécnico de Viana do Castelo
Portugal
linafonseca@ese.ipv.pt

Luís Teixeira de Oliveira

Faculdade de Ciências, Universidade do Porto
Portugal
loliveir@fc.up.pt

Luis Conde

Barry University
United States of America
lconde@barry.us

Marcelo Borba

Universidade Estadual de S. Paulo
Brazil
mborba@rc.unesp.br

Márcia Jussara Hepp Rehfeldt

Centro Universitário Univates
Brazil
mrehfeld@univates.br

Maria de Fátima Morais Sardinha

CIEC - Centro de Investigação em Estudos da
Criança
Portugal
fatimasardinha@gmail.com

María del Carmen Olvera-Martínez

Centro de Investigación y de Estudios
Avanzados del Instituto Politécnico Nacional
Mexico
mcolvera@cinvestav.mx

Maria Madalena Dullius

Centro Universitário Univates
Brazil
madalena@univates.br

Maria Teresa Pimentel Cardoso
Escola Secundária de Santa Maria Maior
Portugal
terpimentel@gmail.com

Marisa Quaresma
Instituto de Educação da Universidade de Lisboa
Portugal
mq@campus.ul.pt

Marli Duffles Donato Moreira
Universidade do Porto
Portugal
marliddmoreira@gmail.com

Marli Teresinha Quartieri
Centro Universitário UNIVATES
Brazil
mtquartieri@univates.br

Matias Camacho
University of Laguna
Spain
mcamacho@ull.edu.es

Mehmet Turegun
Barry University
United States of America
mturegun@barry.edu

Melanie Münz
Goethe Universitat Frankfurt
Germany
muenz@math.uni-frankfurt.de

Melissa James
Springer, SBM
United States of America
melissa.james@springer.com

Michal Tabach
Tel-Aviv University
Israel
tabachm@post.tau.ac.il

Miguel Figueiredo
PhD Student, Instituto de Educação da Universidade de Lisboa
Portugal
mafigueiredo@campus.ul.pt

Milton Rosa
Centro de Educação Aberta e a Distância -
Universidade Federal de Ouro Preto
Brazil
milton@cead.ufop.br

Mónica Ester Villarreal
Facultad de Matemática, Astronomía y Física -
Univ. Nacional de Córdoba
Argentina
mvilla@famaf.unc.edu.ar

Nashwa Ismail
University of Southampton
United Kingdom
nsei1e09@soton.ac.uk

Nélia Amado
Universidade do Algarve e UIDEF, Instituto de Educação da Universidade de Lisboa
Portugal
namado@ualg.pt

Norma Presmeg
Illinois State University
United States of America
npresmeg@msn.com

Nuno Amaral
Escola Básica 2,3 Sophia de Mello Breyner
Andresen
Portugal
nualroam@gmail.com

Radhakrishnan Nair
German University of Technology in Oman
Sultanate of Oman
rk.nair@gutech.edu.om

Rosa Antónia Tomás Ferreira
Faculdade de Ciências, Universidade do Porto & CMUP
Portugal
rferreir@fc.up.pt

Sabine Stöcker-Segre
Davidson Institute of Science Education
Israel
sabine.segre@weizmann.ac.il

Sandra Nobre

Unidade de Investigação do Instituto de
Educação da Universidade de Lisboa
Portugal
sandraggnobre@gmail.com

Sandra Pinheiro

Escola Básica 2/3 Frei João de Vila do Conde
Portugal
sandrapinheiro@ipvc.pt

Sílvia Reis

Agrupamento de Escolas de Valpaços
Portugal
silviapreis@hotmail.com

Susana Carreira

Universidade do Algarve e UIDEF, Instituto de
Educação da Universidade de Lisboa
Portugal
scarrei@ualg.pt

Yuly Marsela Vanegas

Barcelona University
Spain
ymvanegas@ub.edu

SPONSORS

The Organizing Committee is grateful to:



Problem@Web International Conference

An organization of

