

A FREQUENCY-DOMAIN RECEIVER FOR ASYNCHRONOUS SYSTEMS EMPLOYING CP-ASSISTED DS-CDMA SCHEMES

Rui Dinis and Paulo Silva

ISR-Instituto Superior Técnico, Lisboa, Portugal, rdinis@ist.utl.pt

ABSTRACT

In this paper we consider the uplink transmission within CP-assisted (Cyclic Prefix) DS-CDMA (Direct Sequence Code Division Multiple Access) systems and we present a frequency-domain MUD (MultiUser Detection) receiver with iterative estimation and compensation of residual frequency errors.

The proposed receiver is suitable for broadband wireless systems, with performances that can be close to the single-user MFB (Matched Filter Bound), even for fully loaded systems and/or in the presence of strong interfering signals. The receiver is powerful enough for typical asynchronous scenarios, requiring only a coarse synchronization between users.¹

KEY WORDS

DS-CDMA, Multiuser Detection, Frequency-Domain Processing, Asynchronous Systems

1 Introduction

DS-CDMA schemes (Direct Sequence Code Division Multiple Access) allow good capacities, together with high system flexibility. Moreover, contrarily to TDMA schemes (Time Division Multiple Access), all users transmit continuously, regardless of the bit rates, reducing significantly the peak power requirements for the amplifiers. This, combined with the relatively low envelope fluctuations of the DS-CDMA signal associated to each spreading sequence, makes these schemes good candidates for broadband wireless systems, especially at the uplink. However, for severely time-dispersive channels the loss of orthogonality between users can lead to significant performance degradation, unless very high-complexity MUD (MultiUser Detection) receiver structures are employed.

CP-assisted (Cyclic Prefix) block transmission techniques are known to be appropriate for severely time-dispersive channels, since they allow low-complexity, FFT-based (Fast Fourier Transform) receiver implementations [1, 2]. This concept can be successfully employed with DS-CDMA schemes [3]. The receiver is particularly simple at the downlink: since

all spreading codes are affected by the same multipath channel, the receiver can be based on a simple FDE (Frequency-Domain Equalizer), operating at the chip level, followed by the despreading procedure. To avoid significant noise enhancement, the FDE is usually optimized under the MMSE (Minimum Mean-Squared Error) criterion [4], which means that we are not able to fully orthogonalize the different spreading codes. Therefore, we can have significant residual interference levels, especially when different users have different powers. To avoid this problem, a promising nonlinear receiver structure was proposed in [5] which employs an IB-DFE (Iterative Block Decision feedback Equalization) [6, 7] which is especially designed for DS-CDMA signals.

The receiver design for the uplink is more challenging, due to the fact that the signals associated to different users are affected by different propagation channels. A promising frequency-domain receiver for the uplink of CP-assisted systems was recently proposed [8, 9]. This receiver, which takes advantage of the spectral correlations inherent to cyclostationary signals [10] for the separation of the different users, combined with iterative interference cancellation, has excellent performances in synchronous systems. However, since it is very difficult to maintain a good synchronization between different users, some time and, especially, frequency misalignments are almost unavoidable.

In this paper we consider the receiver design for the uplink transmission in asynchronous CP-assisted DS-CDMA systems. We present an iterative frequency-domain MUD receiver with interference cancellation, together with the estimation and compensation of residual frequency errors.

This paper is organized as follows: the CP-assisted block transmission DS-CDMA schemes considered here are described in sec. 2. In sec. 3 we describe the basic MUD receiver considered in this paper. In Sec. 4 we shown how one can modify the basic receiver to cope with asynchronous systems. Sec. 5 presents a set of performance results and sec. 6 is concerned with the conclusions of the paper.

¹This work was partially supported by the FCT project POSI/CPS/46701/2002 - MC-CDMA and the B-BONE project IST-2003-507607.

2 CP-Assisted DS-CDMA

Let us consider the uplink transmission in DS-CDMA systems employing CP-assisted block transmission techniques. We have P users, transmitting blocks with the same dimensions. For the sake of simplicity, it is also assumed that all users have the same spreading factor K and the same data rate.

The size- M data block to be transmitted by the p th user is $\{a_{n,p}; n = 0, 1, \dots, M-1\}$, with $a_{n,p}$ selected from a given constellation. The corresponding chip block to be transmitted is $\{s_{n,p}; n = 0, 1, \dots, N-1\}$, where $N = MK$ and $s_{n,p} = a_{\lfloor n/K \rfloor, p} c_{n,p}$ ($\lfloor x \rfloor$ denotes "larger integer not higher than x "), with $c_{n,p}$ denoting the spreading symbols. Throughout this paper, it is assumed that $\{c_{n,p}; n = mK, mK+1, \dots, mK+K-1\}$, is the product of an K -length Hadamard-Walsh sequence with a pseudo-random scrambling sequence common to all users of the BS (Base Station)²; the spreading sequence is also assumed to be periodic, with period K (i.e., $c_{n+K,p} = c_{n,p}$).

The signal received at the BS is sampled at the chip rate (the generalization for multiple samples per chip is straightforward) and the CP is removed, leading to the time-domain block $\{y_n; n = 0, 1, \dots, N-1\}$. It can be shown that, when the CP is longer than the overall channel impulse response for each user, the corresponding frequency-domain block is $\{Y_k; k = 0, 1, \dots, N-1\}$, where $Y_k = \sum_{p=1}^P \xi_p S_{k,p} H_{k,p}^{Ch} + N_k$, with $H_{k,p}^{Ch}$ denoting the channel frequency response for the p th user and the k th frequency and N_k the channel noise for that frequency (for the sake of simplicity, a synchronous system is assumed in this section; the extension to asynchronous scenarios will be considered in sec. 4) and ξ_p accounts for the propagation losses between the p th transmitter and the receiver.

It is shown in [8, 9] that $Y_k = \sum_{p=1}^P A_{k \bmod M, p} H_{k,p} + N_k$, with $H_{k,p} = \frac{1}{K} \xi_p H_{k,p}^{Ch} C'_{k,p}$ denoting the equivalent channel frequency response for the p th user and the k th frequency and $\{C'_{k,p}; k = 0, 1, \dots, N-1\} = \text{DFT} \{c'_{n,p}; n = 0, 1, \dots, N-1\}$, where $c'_{n,p} = c_{n,p}$ for $0 \leq n < K$ and 0 otherwise. Clearly, there is a K -order multiplicity in the samples $S_{k,p}$ and, consequently, in the samples Y_k . This multiplicity, which is related to the spectral correlations that are inherent to the cyclostationary nature of the transmitted signals [10], will be used in our MUD design.

²It should be pointed out that, since we are considering the uplink transmission, an orthogonal spreading is not mandatory. In fact, if the channels associated to different users are uncorrelated and severely time-dispersive, the achievable performances are almost the same.

3 Basic Receiver Structure

We consider an iterative frequency-domain MUD receiver with interference cancellation. Each iteration consists of P detection stages, one for each user, i.e., we adopted a SIC approach (Successive Interference Cancellation), although a PIC approach (Parallel Interference Cancellation) could also be employed [9]. When detecting a given user, the interference from previously detected users is canceled, as well as the residual ISI (Inter-Symbol Interference) associated to that user (the users are ordered in power, i.e., the first user to be detected is the one with larger average power and the last is the one with lower average power³).

For a given iteration, the detection of the p th user employs the structure depicted in fig. 1, where we have a feedforward filter, followed by a decimation procedure and P feedback filters (one for each user). The feedforward filter is designed to minimize both the ISI and the multiuser interference that cannot be canceled by the feedback filters, due to decision errors in the previous detection steps. After an IDFT operation, the corresponding time-domain outputs are passed through a hard-decision device so as to provide an estimate of the data block transmitted by the p th user. If we do not have any information about the users' data blocks, the receiver reduces to a linear frequency-domain MUD.

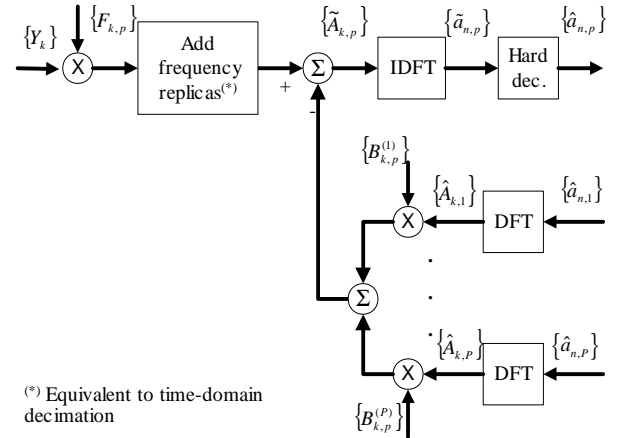

Figure 1. Basic structure for the detection of the p th user.

The K -order multiplicity implicit in the samples Y_k is employed to separate the users. This means that, for each iteration, the frequency-domain samples associated with the p th user at the detector output are given by

$$\tilde{A}_{k,p} = \sum_{l=0}^{K-1} F_{k+lM,p} Y_{k+lM} - \sum_{p'=1}^P B_{k,p}^{(p')} \hat{A}_{k,p'}$$

³The detection order has a significant impact on the receiver performance for the first iteration; however, after some iterations, we have almost the same performance regardless of the detection order.

$$= \sum_{l=0}^{K-1} F_{k+lM,p} Y_{k+lM} - B_{k,p}^{(p)} \hat{A}_{k,p} - \sum_{p' \neq p} B_{k,p}^{(p')} \hat{A}_{k,p'} \quad (1)$$

where $F_{k,p}$ ($k = 0, 1, \dots, N-1$) denote the feedforward coefficients and $B_{k,p}^{(p')}$ ($k = 0, 1, \dots, M-1$; $p' = 1, 2, \dots, P$) denote the feedback coefficients. The block $\{\hat{A}_{k,p'}; k = 0, 1, \dots, M-1\}$ is the DFT of the block $\{\hat{a}_{n,p'}; n = 0, 1, \dots, M-1\}$, where the time-domain samples $\hat{a}_{n,p'}, n = 0, 1, \dots, M-1$, are the latest estimates for the transmitted symbols associated to the p' th user, i.e., the hard-decisions associated with the block of time-domain samples $\{\tilde{a}_{n,p'}; n = 0, 1, \dots, M-1\} = \text{IDFT}\{\hat{A}_{k,p'}; k = 0, 1, \dots, M-1\}$. Since we are considering a SIC strategy [8], for the i th iteration, $\hat{a}_{n,p'}$ is associated with the i th iteration for $p' < p$ and with the $(i-1)$ th iteration for $p' \geq p$ (in the first iteration, we do not have any information for $p' \geq p$ and the corresponding $\hat{a}_{n,p'}$ are zero).

It can be shown that the optimum forward coefficients, $\{F_{k,p}; k = 0, 1, \dots, N-1\}$, are the solution of the following system of K equations [8, 9]:

$$\sum_{p'=1}^P (1 - \rho_{p'}^2) H_{k+lM,p'}^* \sum_{l'=0}^{K-1} F_{k+l'M,p} H_{k+l'M,p'} + \alpha_p F_{k+lM,p} = H_{k+lM,p}^*, \quad l = 0, 1, \dots, K-1, \quad (2)$$

with $\alpha_p = E[|N_k|^2]/E[|A_{k,p}|^2]$ and ρ_p denoting the overall reliability of the decisions used in the feedback loop, given by $\rho_p = E[\hat{a}_{n,p} a_{n,p}^*]/E[|a_{n,p}|^2] = E[\hat{A}_{k,p} A_{k,p}^*]/E[|A_{k,p}|^2]$.

The feedback coefficients, $\{B_{k,p}^{(p')}; k = 0, 1, \dots, M-1\}$ ($p' = 1, 2, \dots, P$), are given by

$$B_{k,p}^{(p')} = \rho_{p'} \left(\sum_{l'=0}^{K-1} F_{k+l'M,p} H_{k+l'M,p'} - \gamma_p \delta_{p,p'} \right) \quad (3)$$

($\delta_{p,p'} = 1$ if $p = p'$ and 0 otherwise), with $\gamma_p = \frac{1}{M} \sum_{k=0}^{M-1} \sum_{l=0}^{K-1} F_{k+lM,p} H_{k+lM,p}$.

The solution of (2) can also be written in the form [9]

$$F_{k+lM,p} = \sum_{p'=1}^P H_{k+lM,p'}^* I_{k,p}^{(p')} \quad (4)$$

($k = 0, 1, \dots, M-1; l = 0, 1, \dots, K-1$), with the set of coefficients $\{I_{k,p}^{(p')}; p' = 1, 2, \dots, P\}$ satisfying the set of P equations

$$\sum_{p''=1}^P I_{k,p}^{(p'')} \cdot \left((1 - \rho_{p'}^2) \sum_{l'=0}^{K-1} H_{k+l'M,p''}^* H_{k+l'M,p'} + \alpha_p \delta_{p',p''} \right) = \delta_{p,p'}, \quad p' = 1, 2, \dots, P. \quad (5)$$

The computation of the feedforward coefficients from (4)-(5) is simpler than the direct computation, from (2), especially when $P < K$.

4 Asynchronous System

The receiver structure considered in the previous section requires perfect time and frequency synchronization between the BS and the MT (Mobile Terminal). Typically, this synchronization is ensured through a feedback channel, from the BS to each MT. Naturally, some residual time and/or frequency errors between BS and the MTs are unavoidable, especially if we want a low-rate feedback channel.

Let us assume that there is a time misalignment ΔT_p on the block associated to the p th MT. If the CP is long enough to cope with the length of the channel impulse response plus $\max_{p \neq p'} |\Delta T_p - \Delta T_{p'}|$ then it can easily be shown that the corresponding received frequency-domain block is $\{Y_k^{(\Delta T)}; k = 0, 1, \dots, N-1\}$, with

$$Y_k^{(\Delta T)} = \sum_{p=1}^P A_{k,p} H_{k,p} \exp(-j2\pi k \Delta T_p / T) + N_k^{(\Delta T)} \quad (6)$$

($k = 0, 1, \dots, N-1$), where the equivalent noise component $N_k^{(\Delta T)}$ has the same statistical properties of N_k . Clearly,

$$Y_k^{(\Delta T)} = \sum_{p=1}^P A_{k,p} H_{k,p}^{(\Delta T_p)} + N_k^{(\Delta T)}, \quad (7)$$

with the equivalent channel frequency response given by $H_{k,p}^{(\Delta T_p)} = H_{k,p} \exp(-j2\pi k \Delta T_p / T)$. Therefore, provided that we have accurate channel estimation and the CP is long enough, we can easily deal with timing errors (these errors are absorbed in the overall channel frequency response associated to each user).

With respect to the frequency errors, it can be shown that the samples at the input of the decision device associated to the p th user are approximately given by

$$\tilde{a}_{n,p'}^{\Delta f_p} \approx \tilde{a}_{n,p'} \exp(j2\pi \Delta f_p n T / M) \quad (8)$$

($n = 0, 1, \dots, M-1$), with T denoting the duration of the useful part of the block and Δf_p denoting the frequency error between the local oscillator at the p th mobile terminal and the local oscillator at the BS (this is a good approximation provided that $\Delta f_p T < 1/2$ and $M \gg 1$). From (8), it is clear that we have a progressive phase rotation along the data symbols, we just have to estimate Δf_p and compensate the phase rotation before the decision device.

The frequency offset can be estimated using specially designed reference blocks [11, 12]. However,

since the frequency error is different for different users, we would need to estimate all frequency errors. This means P reference blocks (multiplexed in the time and/or the frequency), which might lead to significant overheads. To avoid this problem, we will consider a modified version of the iterative receiver proposed in [13] that combines an IB-DFE with an iterative, decision-directed estimation and compensation of frequency errors.

For each iteration, the detection of the p th user can be made using the structure depicted in fig. 2. Δf_p is estimated as follows:

$$\widehat{\Delta f}_p = \frac{M}{2\pi\Delta MT} \arg \left\{ \sum_{n=0}^{M-\Delta M-1} \frac{\tilde{a}_{n+\Delta M,p}^{\Delta f} \tilde{a}_{n,p}^{\Delta f*}}{\hat{a}_{n+\Delta M,p} \hat{a}_{n,p}^*} \right\}, \quad (9)$$

with $\Delta M \approx 2M/3$. To avoid high error rates in $\hat{a}_{n,p}$, the frequency error cannot be too high (say, $\Delta f_p T < 0.2$ or 0.3).

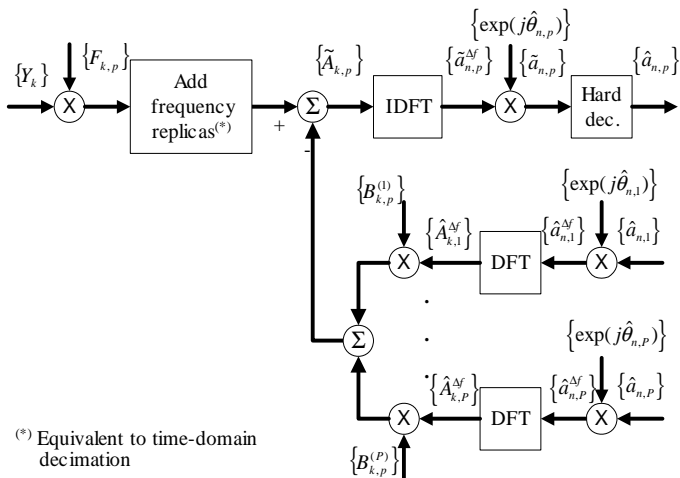

Figure 2. Detection of the p th user in the presence of frequency errors ($\theta_{n,p} = 2\pi\Delta f_p nT/M$).

5 Performance Results

In this section, we present a set of performance results concerning the proposed MUD receiver. We consider the uplink transmission within a CP-assisted DS-CDMA system with spreading factor $K = 4$, $P = 4$ users (i.e., a fully loaded scenario) and $M = 64$ data symbols for each user, corresponding to blocks with length $N = KM = 256$, plus an appropriate cyclic extension. QPSK constellations, with Gray mapping, are employed and we consider a severely time-dispersive channel and perfect channel estimation conditions. The CP is assumed to be long enough to cope with the multipath propagation effects, plus timing errors.

Let us first assume perfect carrier synchronization between all MTs and the BS. We will also assume that the signals associated to different users have the same average power at the receiver (i.e., the BS), which corresponds to an "ideal average power control".

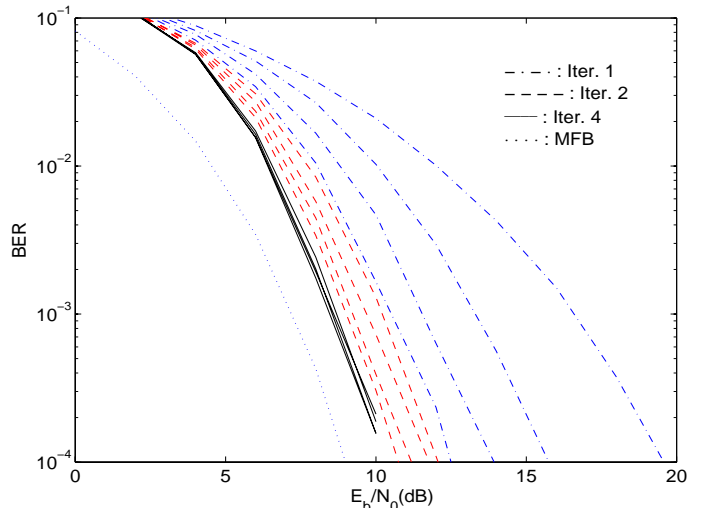

Figure 3. BER for each user, when the proposed iterative receiver is employed (for a given iteration, the users that are detected later have better BER).

Fig. 3 shows the impact of the number of iterations on the BER for each user. For the sake of comparisons, we also include the corresponding MFB performance (Matched Filter Bound), defined as

$$P_{b,p}^{MFB} = E \left[Q \left(\sqrt{\frac{2E_b}{N_0} \frac{1}{N} \sum_{k=0}^{N-1} |H_{k,p}|^2} \right) \right], \quad (10)$$

where the expectation is over the set of channel realizations (it is assumed that $E[|H_{k,p}|^2] = 1$ for any k).

From this figure, we can observe that our iterative receiver is able to separate the different users. For a given iteration, the users that are detected first face stronger interference levels and have worse BER. This is especially important at the first iteration. After four iterations the performances are already similar for all users, and close to the MFB.

Let us consider now a scenario where the signals associated to different users have different average powers at the receiver. We will consider two classes of users, C_L and C_H , with different average powers at the receiver. The performance results presented in fig. 4 concern the case where the average power of C_H users is 10dB above the average power of C_L users and a fully loaded scenario, with two C_L users and two C_H users. Clearly, the C_L users face strong interference levels. Once again, the proposed iterative receiver allows significant performance gains. The performance of low power users asymptotically approaches the MFB when we increase the number of iterations; however, for high power users, the BER at 10^{-4} is still between 1 or 2dB from the MFB. This can be explained from the fact that the BER is much lower for high-power users, allowing an almost perfect interference cancellation of their effects on low-power users; therefore, the corresponding performances can be very close to the

MFB. The higher BERs for the low-power users preclude an appropriate interference cancellation when we detect high-power users.

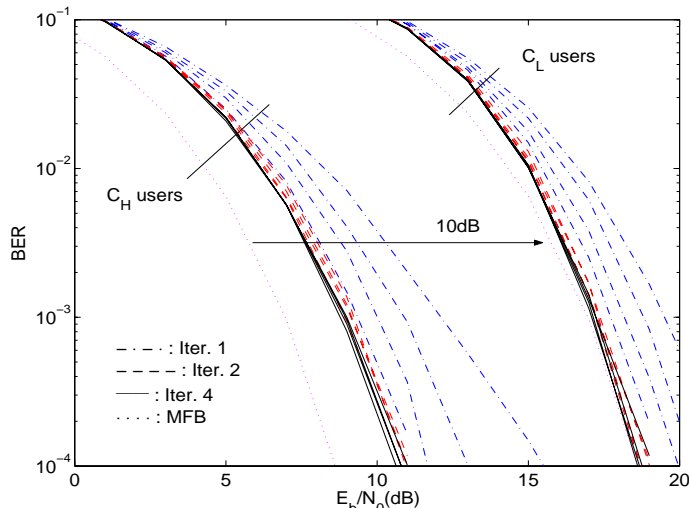

Figure 4. BER performances as a function of the E_b/N_0 of C_H users (average power of C_H users 10dB above the average power of C_L users).

Let us consider now an asynchronous system. Since the timing errors can be easily absorbed by the CP, we will consider only the impact of frequency errors. Fig. 5 concerns the case where the different users have uncorrelated frequency errors and we employ the technique described in the previous section for estimating and compensating the residual phase rotations (for the sake of comparisons we also include the case without compensation and with perfect compensation of the phase rotation). Clearly, the frequency errors can lead to significant performance degradation, but the proposed receiver allows a good compensation of its effects.

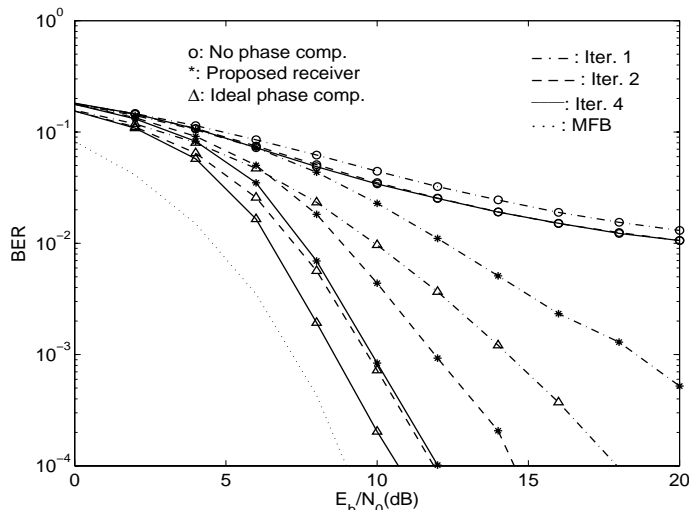

Figure 5. BER performances for each iteration, averaged over all users, when the Δf_p are uniformly distributed in $[-0.3/T, 0.3/T]$.

6 Conclusions

In this paper we considered the uplink transmission within CP-assisted DS-CDMA systems and we presented a frequency-domain MUD receiver with iterative interference cancellation that is suitable to asynchronous systems.

Our performance results showed that the proposed receiver is suitable for broadband wireless systems, with performances that can be close to the single-user MFB, even for fully loaded systems and/or in the presence of strong interfering signals. It was also shown that the proposed receiver is powerful enough for typical conditions, requiring only a coarse synchronization between users.

References

- [1] A. Gusmão, R. Dinis, J. Conceição, and N. Esteves, "Comparison of Two Modulation Choices for Broadband Wireless Communications", *IEEE VTC'00 (Spring)*, May 2000.
- [2] D. Falconer et al, "Frequency Domain Equalization for Single-Carrier Broadband Wireless Systems", *IEEE Comm. Mag.*, April 2002.
- [3] K. Baum et al, "Cyclic-Prefix CDMA: An Improved Transmission Method for Broadband DS-CDMA Cellular Systems", *IEEE WCNC*, pp. 183–188, 2002.
- [4] A. Gusmão, R. Dinis and N. Esteves, "On Frequency-domain Equalization and Diversity Combining for Broadband Wireless Communications", *IEEE Trans. on Comm.*, July 2003.
- [5] P. Silva and R. Dinis, "An Iterative Frequency-Domain Decision Feedback Receiver for CDMA Systems", *ISWCS'04*, Sep. 2004.
- [6] N. Benvenuto and S. Tomasin, "Block Iterative DFE for Single Carrier Modulation", *IEE Elec. Let.*, Sep. 2002.
- [7] R. Dinis, A. Gusmão, and N. Esteves, "On Broadband Block Transmission over Strongly Frequency-Selective Fading Channels", *Wireless 2003*, July 2003.
- [8] P. Silva and R. Dinis, "SIC and PIC Multiuser Detection for Prefix-Assisted DS-CDMA Systems", *WOC'05*, Banff, Canada, July 2005.
- [9] P. Silva and R. Dinis, "Frequency-Domain Multiuser Detection for CP-Assisted DS-CDMA Signals", *IEEE VTC'06 (Spring)*, May 2006.
- [10] W. Gardner, "Exploitation of Spectral Redundancy in Cyclostationary Signals", *IEEE Signal Processing Mag.*, Aug. 1991.
- [11] P. Moose, "A Technique for Orthogonal Frequency Division Multiplexing Frequency Offset Correction", *IEEE Trans. on Comm.*, Oct. 1994.
- [12] T. Keller and L. Hanzo, "Orthogonal Frequency Division Multiplex Synchronization Techniques for Wireless Local Area Networks", *IEEE PIMRC'96*, Oct. 1996.
- [13] T. Araújo and R. Dinis, "Iterative Equalization and Carrier Synchronization for Single-Carrier Transmission over Severe Time-Dispersive Channels", *IEEE GLOBECOM'04*, Nov.–Dec. 2004.