

- Técnicas de Contenção**
 Entrançado Vivo
- Estrutura de Mobilidade**
 Pedonal
 Ciclável
 Automóvel
 Passadiço de madeira
 Estruturas em blocos de betão
- Muro existente a recuperar
 Curva de nível existente
 Limite da área de Anteprojecto

Escala: 1.1500

Pormenor 01 - Caminho pedonal / Ciclovía

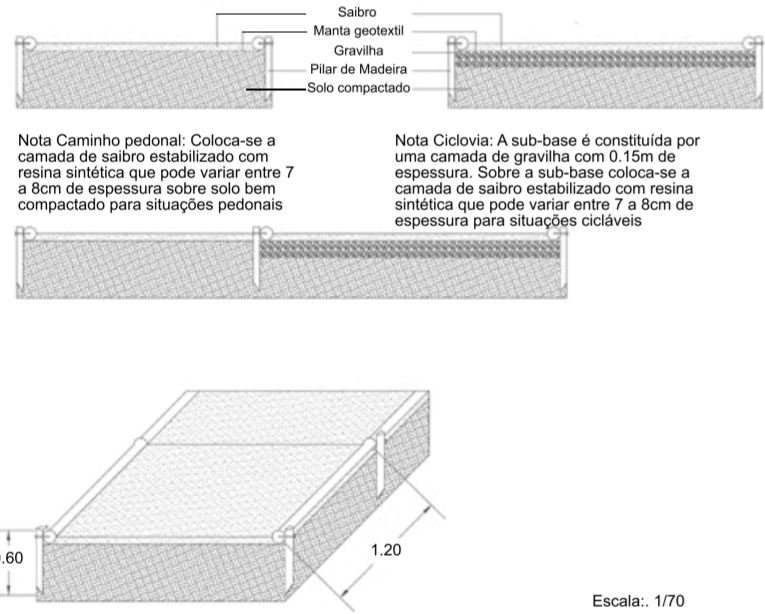

Pormenor 02 - Entrançado Vivo

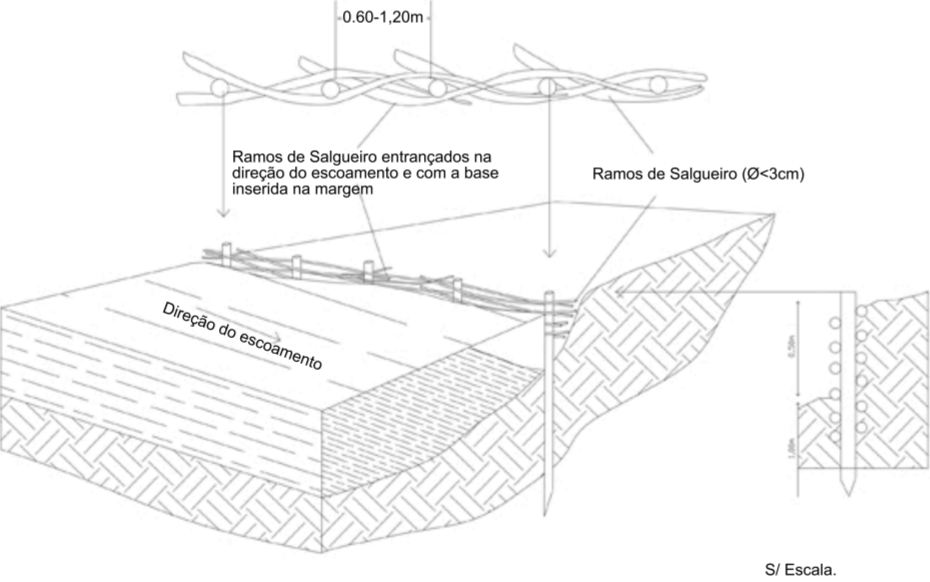

Pormenor 03 - Rede de Reposo

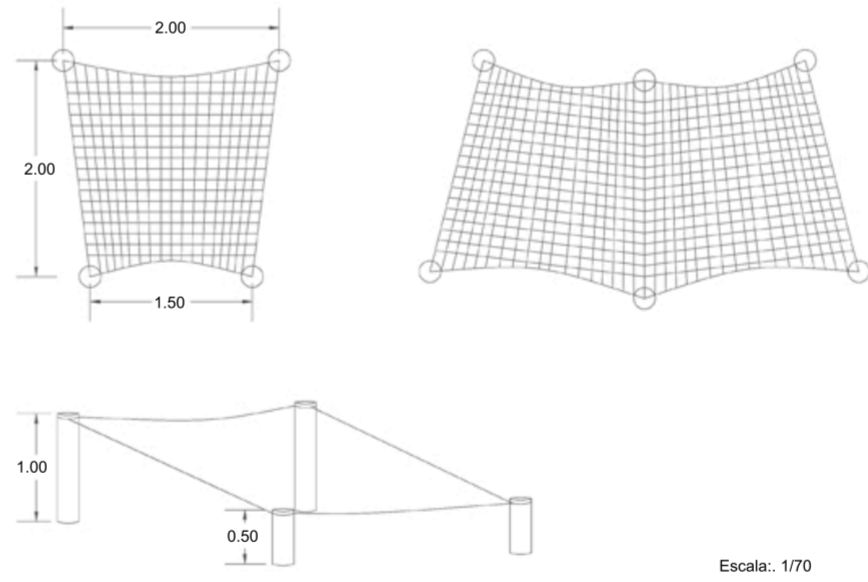

Pormenor 04 - Banco de Madeira

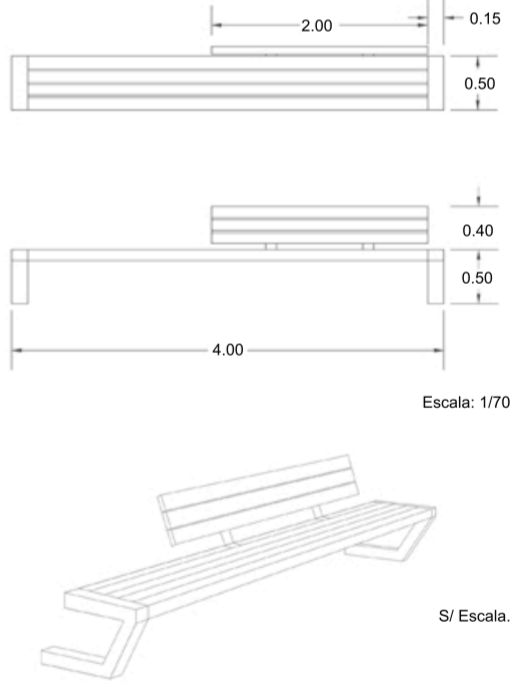

Pormenor 05 - Blocos de Betão

